

Absolute encoders – singleturn

Standard magnetic	Sendix M5858A (shaft)	SAE J1939
--------------------------	------------------------------	------------------



The Sendix M5858A is a magnetic singleturn encoder in compact design. High robustness and high resolution make this encoder the ideal device for use in demanding applications.

SAE J1939

Safety-Lockplus™	High rotational speed	Temperature range -40...+85°C	High protection level IP	High shaft load capacity	Shock / vibration resistant	Reverse polarity protection

Highest robustness

- Sturdy bearing construction in Safety-Lockplus™ design for particularly high resistance.
- Extra large bearings.
- Mechanically protected shaft seal.
- Wide temperature range -40 °C ... +85 °C.

Up-to-the-minute fieldbus performance

- Up-to-the-minute fieldbus performance in the application: SAE J1939 with CAN-highspeed to ISO 11898.
- Fast determination of the operating status via two-color LED.

Order code 8.M5858A.XX3X.3222
Shaft version Type

a Version

- 3 = clamping flange, IP65, ø 58 mm [2.28"]
- 4 = synchro flange, IP65, ø 58 mm [2.28"]

b Shaft (ø x L), with flat

- 1 = ø 6 x 12.5 mm [0.24 x 0.49"]
- 5 = ø 10 x 20 mm [0.39 x 0.79"]

c Interface / supply voltage

- 3 = SAE J1939 / 10 ... 30 V DC

d Type of connection

- 2 = radial cable, 1 m [3.28'] PVC
- B = radial cable, special length PVC *)
- 4 = radial M12 connector, 5-pin

*) Available special lengths (connection types B):
 2, 3, 5, 8, 10, 15 m [5.56, 9.84, 16.40, 26.25, 32.80, 49.21']
 order code expansion .XXXX = length in dm
 ex.: 8.M5858A.313B.3222.0030 (for cable length 3 m)

e Fieldbus profile

- 32 = SAE J1939

Optional on request

- Ex 2/22 (only for connection type 4)

Absolute encoders – singleturn

Standard magnetic		Sendix M5858A (shaft)	SAE J1939
Mounting accessory for shaft encoders			Order no.
Coupling	Bellows coupling ø 19 mm [0.75"] for shaft 10 mm [0.39"]		8.0000.1102.1010
Cables and connectors			Order no.
Preassembled cables	M12 female connector with coupling nut, 5-pin, A coded, straight single ended 5 m [16.40'] PVC cable	Bus in	05.00.6091.A211.005M
	M12 female connector with coupling nut, 5-pin, A coded, straight Deutsch connector DT04, male contacts, 6-pin, straight 1 m [3.28'] PVC cable	Bus in	05.00.6091.22C7.001M
Connectors	M12 female connector with coupling nut, 5-pin, A coded, straight (metal)	Bus in	8.0000.5116.0000

Further Kübler accessories can be found at: kuebler.com/accessories
 Further Kübler cables and connectors can be found at: kuebler.com/connection-technology

Technical data

Mechanical characteristics	
Maximum speed	4000 min ⁻¹ 2000 min ⁻¹ (continuous)
Starting torque at 20 °C [68 °F]	< 0.01 Nm
Shaft load capacity	radial 80 N axial 40 N
Weight	approx. 280 g [9.88 oz]
Protection acc. to EN 60529/DIN 40050-9	IP65
Working temperature range	-40 °C ... +85 °C [-40 °F ... +185 °F]
Materials	shaft V2A flange aluminum housing zinc die-cast cable PVC
Shock resistance acc. to EN 60068-2-27	5000 m/s ² , 4 ms
Vibration resistance acc. to EN 60068-2-6	300 m/s ² , 10 ... 2000 Hz

Electrical characteristics	
Supply voltage	10 ... 30 V DC
Current consumption (no load)	max. 30 mA
Reverse polarity protection of the supply voltage	yes
Short-circuit proof outputs	yes ¹⁾

Interface characteristics SAE J1939	
Resolution	1 ... 16.384 (14 bit), scalable default: 16.384 (14 bit)
Angular measurement deviation ²⁾	±0,5°
Repeat accuracy	±0.2°
Interface	CAN high-speed acc. to ISO 11898, CAN specification 2.0 B
Protocol	SAE J1939
Power-ON time	< 1200 ms
Baud rate	250 kbit/s switchable by software to 500 kbit/s
Node address	software configurable
Termination	software configurable

Approvals	
E1 compliant in accordance with	ECE guideline
UL compliant in accordance with	File no. E224618
CE compliant in accordance with	
EMC Directive	2014/30/EU
RoHS Directive	2011/65/EU
ATEX Directive	2014/34/EU (for Ex 2/22 variants)

1) Short circuit proof to 0 V or to output when supply voltage correctly applied.
 2) Over the whole temperature range.

Absolute encoders – singleturn

Standard magnetic	Sendix M5858A (shaft)	SAE J1939
--------------------------	------------------------------	------------------

General information concerning SAE J1939

The protocol J1939 originates from the international Society of Automotive Engineers (SAE) and operates on the physical layer with high speed CAN as per ISO11898. The application emphasis lies in the area of the power train and chassis of commercial vehicles. It serves to transfer diagnostic data (for example, motor speed, position, temperature) and control information. Type series M3658 and M3678 encoders support the total functionality of J1939.

This protocol is a multimaster system with decentralized network management that does not involve channel-based communication.

It supports up to 254 logic nodes and 30 physical control devices per segment. The information is described as parameters (signals) and combined on 4 memory pages (data pages) into parameter groups (PGs). Each parameter group can be identified via a unique number, the parameter group number (PGN). Independently of this, each signal is assigned a unique SPN (suspect parameter number).

The major part of the communication occurs cyclically and can be received by all control devices without the explicit request for data (Broadcast). Furthermore the parameter groups are optimized to a length of 8 data bytes. This enables very efficient utilization of the CAN protocol. If greater amounts of data need to be transferred, then transport protocols (TP) can be used: BAM (broadcast announce message) and CMTD (connection mode data transfer). With BAM TP the transfer of data occurs as a broadcast.

Encoder implementation SAE J1939

- PGNs that are adaptable to the customer's application.
- Resolution of address conflicts -> Address Claiming (ACL).
- Continuous checking whether control addresses have been assigned twice within a network.
- Change of control device addresses during run-time.
- Unique identification of a control device with the help of a name that is unique worldwide. This name serves to identify the functionality of a control device in the network.
- Predefined PGs for position, speed and alarm.
- 250 kbit/s, 29 bit identifier.
- Watchdog controlled device.

A two-color LED, located on the rear of the encoder, signals the operating and fault status of the J1939 protocol, as well as the status of the internal sensor diagnostics.

Terminal assignment

Interface	Type of connection	Cable (isolate unused wires individually before initial start-up)					
2	2, B	Signal:	+V	0 V	CAN_GND	CAN_H	CAN_L
		Cable color:	BN	WH	GY	GN	YE
Interface	Type of connection	M12 connector, 5-pin					
2	4	Signal:	+V	0 V	CAN_GND	CAN_H	CAN_L
		Pin:	2	3	1	4	5

Top view of mating side, male contact base

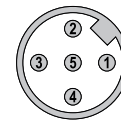

M12 connector, 5-pin

Absolute encoders – singleturn

Standard magnetic	Sendix M5858A (shaft)	SAE J1939
--------------------------	------------------------------	------------------

Dimensions

Dimensions in mm [inch]

Clamping flange, ø 58 [2.28]

Flange type 3

- 1 3 x M4
- 2 3 x M3

D	Fit	L
6 [0.24]	h7	12.5 [0.49]
10 [0.39]	h7	20 [0.79]

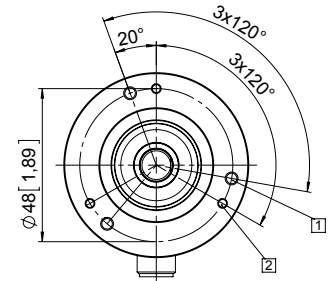
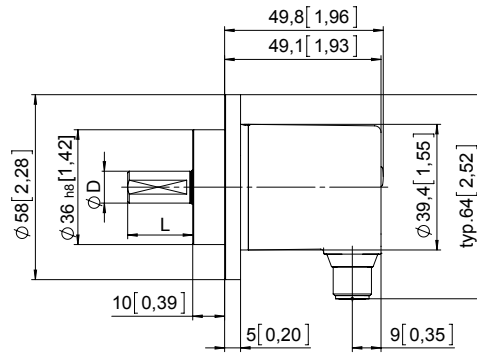

Synchro flange, ø 58 [2.28]

Flange type 4

- 1 3 x M4, 10 [0.39] deep

D	Fit	L
6 [0.24]	h7	12.5 [0.49]
10 [0.39]	h7	20 [0.79]

