

Absolute encoders – multiturn

Standard electronic multiturn, optical	Sendix F5868 / F5888 (shaft / hollow shaft)	EtherNet/IP
---	--	--------------------



New generation - ready for the future.

The optical absolute singleturn and multiturn Sendix F58 EtherNet/IP encoders are based on the latest CIP version v3.32 and EtherNet/IP version v1.30.

Key features are neighborhood detection, gear factor, the calculation of acceleration and simultaneous connection to up to 5 controllers. Thanks to the new framework, the functionality can be extended at any time via the integrated web server by update.



Multiturn resolution	Safety-Lock™	High rotational speed	Temperature range -40°...+80°C	High protection level	High shaft load capacity	Shock / vibration resistant	Magnetic field proof	Reverse polarity protection	Optical sensor

Features

- Scaling of the total resolution via the gear factor.
- High resolution: singleturn up to 19 bit, multiturn up to 24 bit.
- High-precision setting of velocity and acceleration values through filter and hysteresis.
- Device Level Ring (DLR) ring redundancy of the network with two network ports.
- Low RPI time of minimum 1 ms - this makes the encoder usable for time-critical applications up to 1000 Hz update frequency.

Benefits

- Direct mapping of pitch ratios, e.g. for gear ratios or gear reductions.
- Precise position detection.
- Cost and time savings when setting up the control system.
- Communication is maintained when the ring structure is interrupted.

Absolute encoders – multiturn

Standard electronic multiturn, optical	Sendix F5868 / F5888 (shaft / hollow shaft)	EtherNet/IP
---	--	--------------------

Order code	8.F5868	.XXAN.	A3	2	2
Shaft version	Type	a b c d	e		

a Flange

- 1 = clamping flange, IP65 \varnothing 58 mm [2.28"]
- 3 = clamping flange, IP67 \varnothing 58 mm [2.28"]
- 2 = synchro flange, IP65 \varnothing 58 mm [2.28"]
- 4 = synchro flange, IP67 \varnothing 58 mm [2.28"]
- 5 = square flange, IP65 \square 63.5 mm [2.5"]
- 7 = square flange, IP67 \square 63.5 mm [2.5"]

b Shaft ($\varnothing \times L$), with flat

- 1 = 6 x 10 mm [0.24 x 0.39"]
- 2 = 10 x 20 mm [0.39 x 0.79"]
- 3 = 1/4" x 7/8"
- 4 = 3/8" x 7/8"

c Interface / Supply voltage

A = EtherNet/IP / 10 ... 30 V DC

d Type of connection

N = 3 x axial M12 connector, 4-pin

e Fieldbus profile

A3= EtherNet/IP

Options – Standard types (available from 1 piece)

Surface protection salt spray tested with clamping flange IP67 and shaft \varnothing 10 mm:
8.F5868.32AN.A322-C

V2A
DIN 1.4305
AISI 303

Stainless steel V2A ¹⁾
Order expansion:
8.F5868.XXAN.A322-V2A

V4A
DIN 1.4404
AISI 316L

Stainless steel V4A ¹⁾
Order expansion:
8.F5868.XXAN.A322-V4A

Options – on request (for other flange/shaft combinations)

- Surface protection salt spray tested
- Stainless steel V2A
- Stainless steel V4A

Order code	8.F5888	.XXAN.	A3	2	2
Hollow shaft	Type	a b c d	e		

a Flange

- 1 = with spring element long, IP65
- 2 = with spring element long, IP67
- 3 = with stator coupling, IP65 \varnothing 65 mm [2.56"]
- 4 = with stator coupling, IP67 \varnothing 65 mm [2.56"]
- 5 = with stator coupling, IP65 \varnothing 63 mm [2.48"]
- 6 = with stator coupling, IP67 \varnothing 63 mm [2.48"]
- 9 = with torque stop, flexible, IP65
- J = with torque stop, flexible, IP67

b Blind hollow shaft (insertion depth max. 30 mm [1.18"])

- A = \varnothing 10 mm [0.39"]
- B = \varnothing 12 mm [0.47"]
- C = \varnothing 14 mm [0.55"]
- D = \varnothing 15 mm [0.59"]
- E = \varnothing 3/8"
- F = \varnothing 1/2"

c Interface / Supply voltage

A = EtherNet/IP / 10 ... 30 V DC

d Type of connection

N = 3 x axial M12 connector, 4-pin

e Fieldbus profile

A3= EtherNet/IP

Options – Standard types (available from 1 piece)

V2A
DIN 1.4305
AISI 303

Stainless steel V2A ²⁾
Order expansion:
8.F5888.2XAN.A322-V2A

V4A
DIN 1.4404
AISI 316L

Stainless steel V4A ²⁾
Order expansion:
8.F5888.2XAN.A322-V4A

Options – on request (for other flange/hollow shaft combinations)

- Surface protection salt spray tested
- Stainless steel V2A
- Stainless steel V4A

1) Only in conjunction with flange **a** = 3 or 4 and shaft **b** = 1 or 2.
 2) Only in conjunction with flange **a** = 2 and hollow shaft **b** = B or D.

Absolute encoders – multiturn

Standard electronic multiturn, optical		Sendix F5868 / F5888 (shaft / hollow shaft)	EtherNet/IP
Mounting accessory for shaft encoders			Order no.
Coupling	bellows coupling ø 19 mm [0.75"] for shaft 6 mm [0.24"]		8.0000.1102.0606
	bellows coupling ø 19 mm [0.75"] for shaft 10 mm [0.39"]		8.0000.1102.1010
Mounting accessory for hollow shaft encoders Dimensions in mm [inch]			Order no.
Torque pin, ø 4 mm for flange with spring element (flange type 1)	with fixing thread		8.0010.4700.0000
Cables and connectors			Order no.
Preassembled cables	M12 male connector with external thread, 4-pin, D coded, straight single-ended 2 m [6.56'] PUR cable	port 1 + port 2	05.00.6031.4411.002M
	M12 male connector with external thread, 4-pin, D coded, right-angle single-ended 2 m [6.56'] PUR cable	port 1 + port 2	05.00.6031.4511.002M
	M12 female connector with coupling nut, 4-pin, A coded, straight single-ended 2 m [6.56'] PUR cable	power supply	05.00.6061.6211.002M
	M12 female connector with coupling nut, 4-pin, A coded, right-angle single-ended 2 m [6.56'] PUR cable	power supply	05.00.6061.6311.002M
Connectors	M12 male connector with external thread, 4-pin, D coded, straight (metal)	port 1 + port 2	05.WASCSY4S
	M12 male connector with external thread, 4-pin, D coded, right-angle (metal)	port 1 + port 2	8.0000.5128.0000
	M12 female connector with coupling nut, 4-pin, A coded, straight (plastic)	power supply	05.B8141-0
	M12 female connector with coupling nut, 4-pin, A coded, right-angle (plastic)	power supply	05.B8241-0

Further Kübler accessories can be found at: kuebler.com/accessories
 Further Kübler cables and connectors can be found at: kuebler.com/connection-technology

Absolute encoders – multiturn

Standard electronic multiturn, optical	Sendix F5868 / F5888 (shaft / hollow shaft)	EtherNet/IP
---	--	--------------------

Technical data

Mechanical characteristics	
Max. speed	9000 min ⁻¹ (short-term – 10 min) 6000 min ⁻¹ (continuous)
Starting torque at 20 °C [68 °F]	< 0.01 Nm
Moment of inertia	shaft version 3.0 x 10 ⁻⁶ kgm ² blind hollow shaft version 4.0 x 10 ⁻⁶ kgm ²
Load capacity of shaft	radial 80 N axial 40 N
Weight	approx. 0.45 kg [15.87 oz]
Protection acc. to EN 60529	IP65, IP67
Working temperature range	-40 °C ... +80 °C [-40 °F ... +176 °F]
Material	Standard V2A V4A DIN 1.4305 DIN 1.4404 AISI 303 AISI 316L shaft/hollow shaft V2A V2A V4A flange aluminum V2A V4A housing aluminum V2A V4A
Shock resistance acc. EN 60068-2-27	2500 m/s ² , 6 ms
Vibration resistance acc. EN 60068-2-6	100 m/s ² , 55 ... 2000 Hz

Electrical characteristics	
Supply voltage	10 ... 30 V DC
Power consumption (no load)	max. 250 mA
Reverse polarity protection of the supply voltage (+V)	yes

Approvals	
UL compliant in accordance with	File no. E224618
CE compliant in accordance with	EMC Directive 2014/30/EU RoHS Directive 2011/65/EU

Interface characteristics EtherNet/IP

General information	
EtherNet/IP conformance tested acc. to	version CT-12 of 11. Dez. 2014
EtherNet/IP specification	Vol 2, Ed 1.17
CIP specification	Vol 1, Ed 3.16
Protocol	F58x8 Standards & Features CIP Version v3.32 Ethernet/IP Version v1.30 LLDP BOOTP DHCP Device Profile Encoder Device

Adjustable parameters	
<ul style="list-style-type: none"> • Preset • Count direction • Resolution • Unity of speed • IP address • Number of revolutions • Position • Position format • Position limit 	<ul style="list-style-type: none"> • Acceleration unit • Speed limit • Acceleration limit • Scaling • Gear factor • Filter for speed and acceleration • Hysteresis for speed and acceleration

Resolution	
Resolution singleturn (MUR)	scalable 1 ... 524 288 (19 bit) default 262 144 (18 bit)
Number of revolutions (NDR)	scalable 1 ... 16 777 216 (24 bit) default 4 096 (12 bit)
Total resolution (TMR)	scalable 1 ... 8 796 093 022 208 (43 bit) default 1 073 741 824 (30 bit)

Objects (CIP Objects)	
<ul style="list-style-type: none"> • Identity Object • Message Router • Assembly Object • Connection Manager • Position Sensor Object 	<ul style="list-style-type: none"> • Qos Object • Port Object • TCP / IP Interface Object • EtherNet Link Object



EtherNet/IP features	
<ul style="list-style-type: none"> • DLR (Device Level Ring) possible • Qos (Quality of Service) possible • ACD (Address Conflict Detection) 	<ul style="list-style-type: none"> • Multicast and unicast capability • Up to 5 PLC connections

Process data	
<ul style="list-style-type: none"> • Position • Speed data • Acceleration • Errors • Alarms 	<ul style="list-style-type: none"> • Warnings • Offset (for preset) • Battery voltage • Operating voltage • Temperature

Absolute encoders – multiturn

Standard electronic multiturn, optical	Sendix F5868 / F5888 (shaft / hollow shaft)	EtherNet/IP
---	--	--------------------

Terminal assignment bus

Interface	Type of connection	Function	M12 connector, 4-pin					
A	N (3 x M12 connector)	Bus Port 1	Signal:	Transmit data+	Receive data+	Transmit data -	Receive data -	 D coded
			Abbreviation:	TxD+	RxD+	TxD-	RxD-	
			Pin:	1	2	3	4	
		Power supply	Signal:	Voltage +	-	Voltage -	-	 D coded
			Abbreviation:	+ V	-	0 V	-	
			Pin:	1	2	3	4	
		Bus Port 2	Signal:	Transmit data+	Receive data+	Transmit data -	Receive data -	 D coded
			Abbreviation:	TxD+	RxD+	TxD-	RxD-	
			Pin:	1	2	3	4	

Rear side connections and display elements

①	Ethernet Port – Link 2	
②	Supply voltage	
③	Cover screw	
④	Ethernet Port – Link 1	
⑤	Link 2	flashes yellow when connected
⑥	BF – Bus Failure	displays network errors *)
⑦	SF – System Failure	displays system errors *)
⑧	ENC	Shows status of encoder *)
⑨	Link 1	flashes yellow when connected
⑩	Switch: x 100	
⑪	Switch: x 10	
⑫	Switch: x 1	

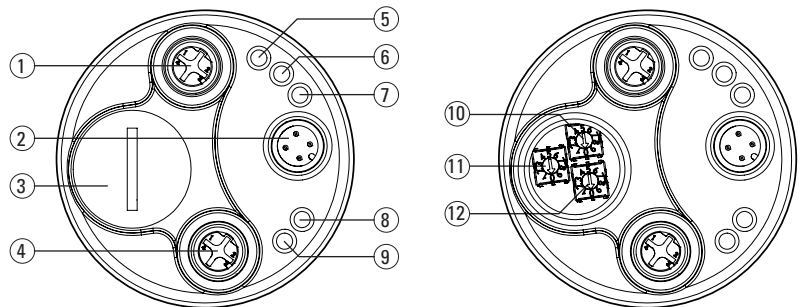

*) see manual

Settings rotary switch

Switch position	Meaning
000	Address assignment via DHCP
1 ... 254	Use stored subnet (standard: 192.168.1.x, mask: 255.255.255.0) The last digit „x“ of the IP address is determined by the rotary switch.
300	Explicit Protection Mode OFF
555	Resetting the encoder to factory setting. To reset, this switch position must be set. If necessary, switch off the operating voltage and switch it on again within 10 seconds. After that, the encoder can be switched off and the switch setting desired during operation can be made. All parameters are now set to factory settings - both the encoder objects and the TCP/IP settings.
800	Explicit Protection Mode ON
Other positions	Reserved, do not use!

Absolute encoders – multiturn

**Standard
electronic multiturn, optical**

Sendix F5868 / F5888 (shaft / hollow shaft)

EtherNet/IP

Dimensions shaft version

Dimensions in mm [inch]

Clamping flange, \varnothing 58 [2.28]

Flange type 1 + 3

- 1 3 x M3, 6 [0.24] deep
- 2 3 x M4, 8 [0.31] deep

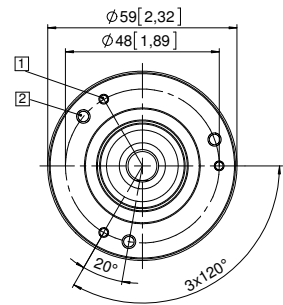
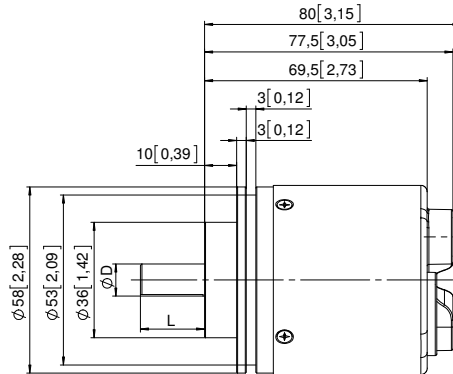

D	Fit	L
6 [0.24]	h7	10 [0.39]
10 [0.39]	f7	20 [0.79]
1/4"	h7	7/8"
3/8"	h7	7/8"

Synchro flange, \varnothing 58 [2.28]

Flange type 2 + 4

- 1 3 x M3, 6 [0.24] deep

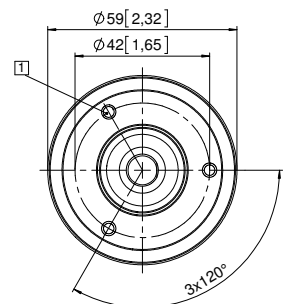
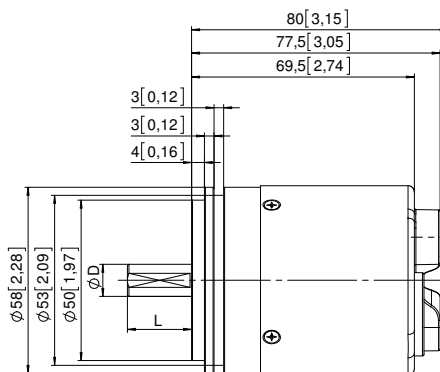

D	Fit	L
6 [0.24]	h7	10 [0.39]
10 [0.39]	f7	20 [0.79]
1/4"	h7	7/8"
3/8"	h7	7/8"

Square flange, \square 63.5 [2.5]

Flange type 5 + 7

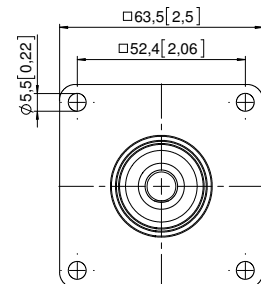
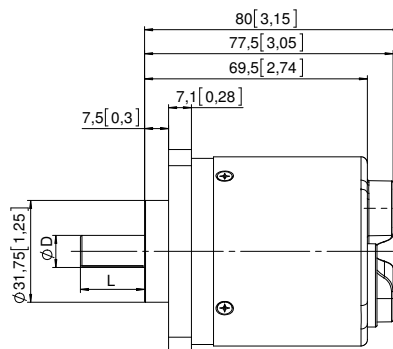

D	Fit	L
6 [0.24]	h7	10 [0.39]
10 [0.39]	f7	20 [0.79]
1/4"	h7	7/8"
3/8"	h7	7/8"

Absolute encoders – multiturn

Standard electronic multiturn, optical	Sendix F5868 / F5888 (shaft / hollow shaft)	EtherNet/IP
---	--	--------------------

Dimensions hollow shaft version

Dimensions in mm [inch]

Flange with spring element, long Flange type 1 + 2

- 1 Slot spring element, recommendation: torque pin DIN 7, \varnothing 4 [0.16]
- 2 3 x M3, 5.5 [0.22] deep
- 3 Recommended torque for the clamping ring 0.6 Nm

D	Fit	L
10 [0.39]	H7	30 [1.18]
12 [0.47]	H7	30 [1.18]
14 [0.55]	H7	30 [1.18]
15 [0.59]	H7	30 [1.18]
3/8"	H7	30 [1.18]
1/2"	H7	30 [1.18]

L = insertion depth max. blind hollow shaft

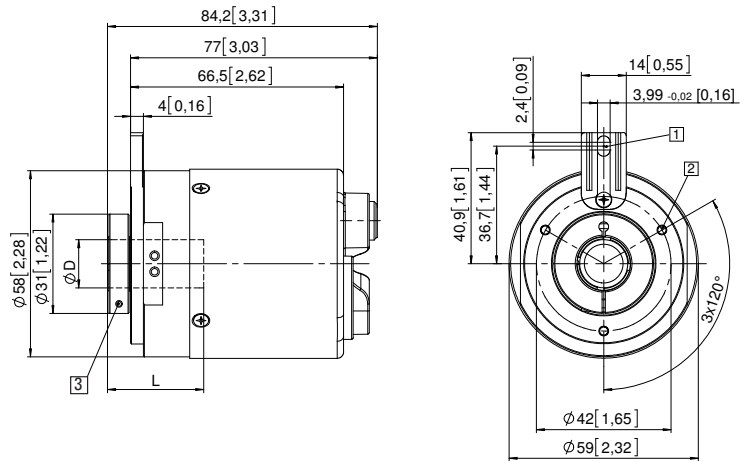

Flange with stator coupling, \varnothing 65 [2.56] Flange type 3 + 4

- 1 Recommended torque for the clamping ring 0.6 Nm

D	Fit	L
10 [0.39]	H7	30 [1.18]
12 [0.47]	H7	30 [1.18]
14 [0.55]	H7	30 [1.18]
15 [0.59]	H7	30 [1.18]
3/8"	H7	30 [1.18]
1/2"	H7	30 [1.18]

L = insertion depth max. blind hollow shaft

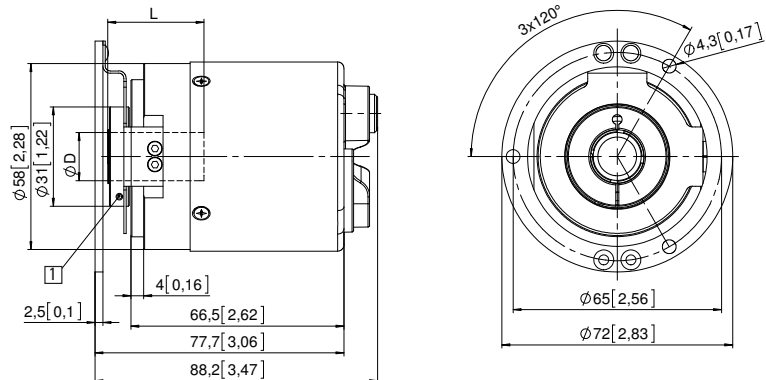

Flange with stator coupling, \varnothing 63 [2.48] Flange type 5 + 6

- 1 Recommended torque for the clamping ring 0.6 Nm

D	Fit	L
10 [0.39]	H7	30 [1.18]
12 [0.47]	H7	30 [1.18]
14 [0.55]	H7	30 [1.18]
15 [0.59]	H7	30 [1.18]
3/8"	H7	30 [1.18]
1/2"	H7	30 [1.18]

L = insertion depth max. blind hollow shaft

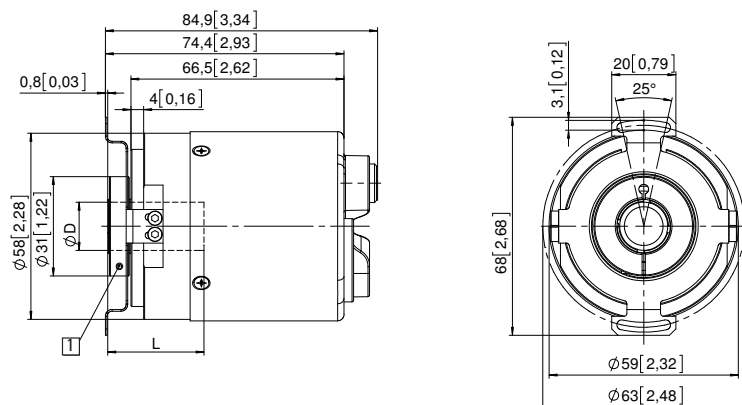

Absolute encoders – multiturn

Standard electronic multiturn, optical	Sendix F5868 / F5888 (shaft / hollow shaft)	EtherNet/IP
---	--	--------------------

Dimensions hollow shaft version

Dimensions in mm [inch]

**Flange with torque stop, flexible
Flange type 9 + J**

1 Recommended torque for the clamping ring 0.6 Nm

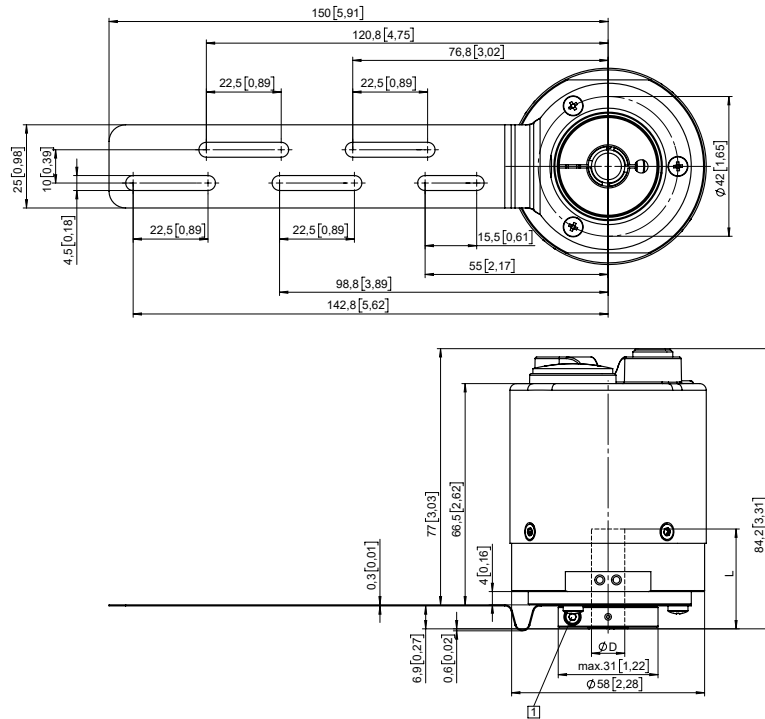

D	Fit	L
10 [0.39]	H7	30 [1.18]
12 [0.47]	H7	30 [1.18]
14 [0.55]	H7	30 [1.18]
15 [0.59]	H7	30 [1.18]
3/8"	H7	30 [1.18]
1/2"	H7	30 [1.18]

L = insertion depth max. blind hollow shaft