

Safe speed monitors

Safety-M compact Basic module	Speed monitoring – SMC1.3	1 axis / 1 encoder system
--	----------------------------------	----------------------------------

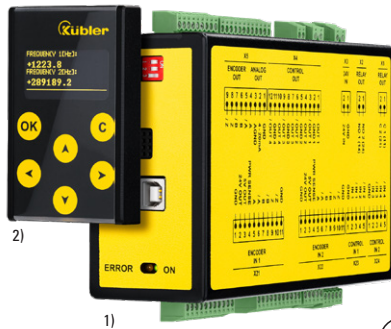

SMC1.3 is a compact safety module of the Safety-M family with integrated drive monitoring for one axis with a safe encoder system. This standalone speed monitor (basic module) can be operated without additional safe PLC.

SMC1.3 is the optimal solution for integration in existing safety circuits or for retrofitting old machines. For safe speed detection, solutions with a safe encoder / incremental sensor (HTL differential, RS422) are supported.

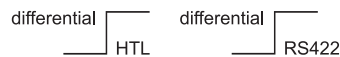

The integrated signal converter and splitter allows an easy connection of controllers, which can operate using the same encoder system. It offers in addition the possibility of issuing an analog rotational speed value, e.g. to replace tachometers or similar.

The device can be parameterized with a removable control and diagnostic display or with the PC software "OSxx". This allows comfortable, comprehensive and simple diagnostics and settings on a PC on site or at the workplace.

The removable operating display (touchscreen) displays various features such as:

- 2-channel frequency display.
- freely scalable for speed, production rates, rotational speeds, stops.
- operating mode and error code display.

- Extensive library of pre-configured safe sensors and command devices. This allows easy parameterizing without programming.
- Complete range of speed-related safe drive monitoring functions equivalent to EN 61800-5-2 already integrated in firmware (SS1, SS2, SDI, SLI, SBC, SMS, SOS, SLS, SSM, STO).
- Integrated signal splitter to forward the encoder signals. No complex, interference-sensitive external wiring when the controller is to use the same signals.
- The signal converter can issue the encoder signal as RS422, HTL differential or as a 4 ... 20 mA analog value.
- Easy snap-on installation on 35 mm C profile rail.
- 8/4 safe control inputs, 4x2 safe control outputs. 2 safe synchronized potential-free relay contacts.
- Contact multiplication or increase of power capability by external contactors in connection with the device-internal monitoring function for external contacts (EDM).
- LED on the front side indicates operating state.
- Removable control and diagnosis display (optional).
- Free "OSxx" parameterization software.

Order code	<table border="1" style="border-collapse: collapse; margin: auto;"> <tr> <td style="padding: 2px 5px;">8</td> <td style="padding: 2px 5px;">.</td> <td style="padding: 2px 5px;">SMC1</td> <td style="padding: 2px 5px;">.</td> <td style="padding: 2px 5px;">3</td> <td style="padding: 2px 5px;">S</td> <td style="padding: 2px 5px;">A</td> <td style="padding: 2px 5px;">.</td> <td style="padding: 2px 5px;">442</td> </tr> <tr> <td></td> <td></td> <td></td> <td></td> <td style="text-align: center; font-size: 8px;">a</td> <td style="text-align: center; font-size: 8px;">b</td> <td style="text-align: center; font-size: 8px;">c</td> <td></td> <td></td> </tr> </table>	8	.	SMC1	.	3	S	A	.	442					a	b	c		
8	.	SMC1	.	3	S	A	.	442											
				a	b	c													
a Encoder interface 3 = 1 x screw terminal HTL differential, RS422	b Internal signal splitting S = with	c Analog output A = 4 ... 20 mA																	

1) Safety-M compact basic module.
 2) Optional control and diagnosis display – to be ordered separately (see the accessories).

Safe speed monitors

Safety-M compact Basic module	Speed monitoring – SMC1.3	1 axis / 1 encoder system
Accessories		Order no.
Control and diagnostic display, OLED touch screen		8.SMCB.100
“OSxx” parameterization software	download at	www.kuebler.com/software
Shield terminal for encoder cable, C profile rail	Shield diameter 3.0 ... 12.0 mm	8.0000.4G06.0312

Further Kübler accessories can be found at: kuebler.com/accessories
 Further Kübler cables and connectors can be found at: kuebler.com/connection-technology.
 You will find an overview of our systems and components for Functional Safety under www.kuebler.com/safety.

Technical data

General data	
Safe digital input lines	8 / 4
Safe digital lines	8 / 4
Safe relay outputs	2 synchronized
Type of connection	pluggable screw terminals
Max. terminal cross section	1.5 mm ² / AWG16, screw terminal
Drive monitoring	1 axis

Electrical characteristics	
Supply voltage	24 V DC / 2 A
Tolerance	±20 %
Current consumption (no load)	max. 150 mA
Power consumption	max. 48 W
Fuse on supply voltage	max. 3.15 A, delayed
Rated encoder power supply data	5 V or 24 V DC (approx. 2V below the supply voltage) / max. 200 mA short-circuit proof

Environmental data	
Operating temperature	-20°C ... +55°C [-4°F ... +131°F] (non condensing)
Storage temperature	-25°C ... +70°C [-13°F ... +158°F] (non condensing)
Protection acc. to EN 60529	IP20
Climate class	3 acc. to DIN 50178 (non condensing)
CE compliant acc. to	EMC guideline 2014/30/EU Machinery directive 2006/42/EC Low voltage guideline 2014/35/EU RoHS guideline 2011/65/EU

Safety characteristics	
Classification	PLd / SIL2
System structure	2 channel (Cat. 3 / HFT = 1)
PFH _d value	5.73 x 10 ⁻⁹ h ⁻¹
DC _{avg}	98.7 %
SFF	98.99 %
MTTF _D	156.5 years
Mission time / Proof test interval	20 years
Reaction times	see operating instructions R60047
Relevant standards	EN ISO 13849-1:2008 EN 62061:2005 EN 61508:2011 EN 60947:2015

EMC	
Relevant standards	EN 61000-6-2:2006 EN 61000-6-4:2011 EN 61326-3-2:2008

Mechanical characteristics	
Size w x h x d	50 x 100 x 165 mm [1.97 x 3.94 x 6.50"]
Weight	390 g [13.76 oz]
Mounting	snap-on mounting on standard head rail
Material	housing plastic
Shock resistance acc. to EN 60068-2-27	300 m/s ² , 11 ms (3 shocks) 170 m/s ² , 6 ms (4000 shocks)
Vibration resistance acc. to EN 60068-2-6	70 m/s ² , 10 ... 200 Hz (20 cycles)

LED display		
ERROR (yellow)	steadily on flashing slowly	error DIP 1 = OFF, factory setting DIP 3 = OFF, programming mode
ON (green)	steadily on	power on

Safe speed monitors

Safety-M compact Basic module	Speed monitoring – SMC1.3	1 axis / 1 encoder system
--	----------------------------------	----------------------------------

Incremental interface (IN1) X21	
Type of connection	1 x pluggable screw terminal, 11-pin
Signal	HTL differential, RS422
Frequency	max. 500 kHz

Digital inputs (IN1, IN2) X23, X24	
Type of connection	2 x pluggable screw terminals, 5-pin
HTL signal (PNP)	proximity switches or digital inputs
Frequency	max. 1 kHz (control signals)
Signal level	PNP (10 ... 30 V DC / 15 mA)
Design	4 x complementary, 8 x single-channel

Relay outputs (OUT) X1, X2	
Type of connection	2 x pluggable screw terminals, 2-pin
Wiring	2 x two internally in line, connected in parallel
Type	positively driven (NO)
Switching ability	5 ... 250 V AC/DC
Switching capacity	5 ... 5000 mA

Digital switching outputs (OUT) X4	
Type of connection	pluggable screw terminal, 12-pin
Signal	HTL / push-pull
Rated data digital output	HTL PNP 2 ... 3 V DC lower than the input voltage 500 mA / output (total 1000 mA)
Design	4 x complementary 8 x single-channel, short-circuit proof
Protective circuit	push-pull

Incremental interface / RS422 (OUT) X5, internal signal splitter	
Type of connection	pluggable screw terminal, 9-pin
Signal	RS422 / HTL differential
Frequency	max. 500 kHz
Signal delay	RS422 <-> RS422: 500 ns HTL <-> RS422: 500 ns RS422 <-> HTL: 500 ns HTL <-> HTL: 500 ns
Source	incremental (X21)

Analog interface (OUT) X5	
Type of connection	pluggable screw terminal, 9-pin
Signal	analog
Resolution	14 bits
Accuracy	±0.1 %
Output	1 ms
Frequency	4 ... 20 mA
Load	max. 270 Ω

USB interface X12	
Type	USB-B female connector
Standard	USB 1.0
Operating system	WIN 7 / 8 / 9 (tested with 1511 build 0586.104)

Safe speed monitors

**Safety-M compact
Basic module**

Speed monitoring – SMC1.3

1 axis / 1 encoder system

Terminal assignment

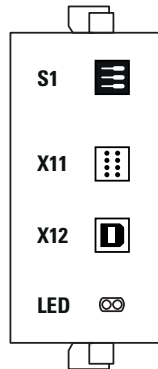
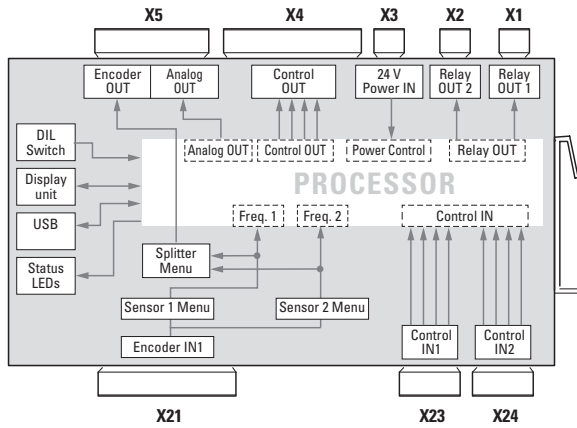

DIP switch S1



ON		Normal operation
OFF	1	Factory setting
	2	Self-test report
	3	Programming mode

X1	
1	2
Relay OUT 1 (NO)	
C1 (11)	C2 (21)

X2	
1	2
Relay OUT 2 (NO)	
NO2 (24)	NO1 (14)

X3	
1	2
Power 24 V IN	
GND	24 V IN

X4											
1	2	3	4	5	6	7	8	9	10	11	12
Control OUT											
OUT 1	GND 1	/OUT 1	OUT 2	GND 2	/OUT 2	OUT 3	GND 3	/OUT 3	OUT 4	GND 4	/OUT 4

X5								
1	2	3	4	5	6	7	8	9
Analog OUT				Encoder OUT				
GND	4 - 20 mA	AGND	A	/A	B	/B	Z	/Z

X21										
1	2	3	4	5	6	7	8	9	10	11
Encoder IN 1										
GND	24 V OUT	5 V OUT	PWR SENSE	A	/A	B	/B	Z	/Z	GND

X23				
1	2	3	4	5
Control IN 1				
GND	IN 1	/IN 1	IN 2	/IN 2

X24				
1	2	3	4	5
Control IN 2				
GND	IN 3	/IN 3	IN 4	/IN 4

Safe speed monitors

Safety-M compact Basic module	Speed monitoring – SMC1.3	1 axis / 1 encoder system
--	----------------------------------	----------------------------------

Dimensions

Dimensions in mm [inch]

Basic module

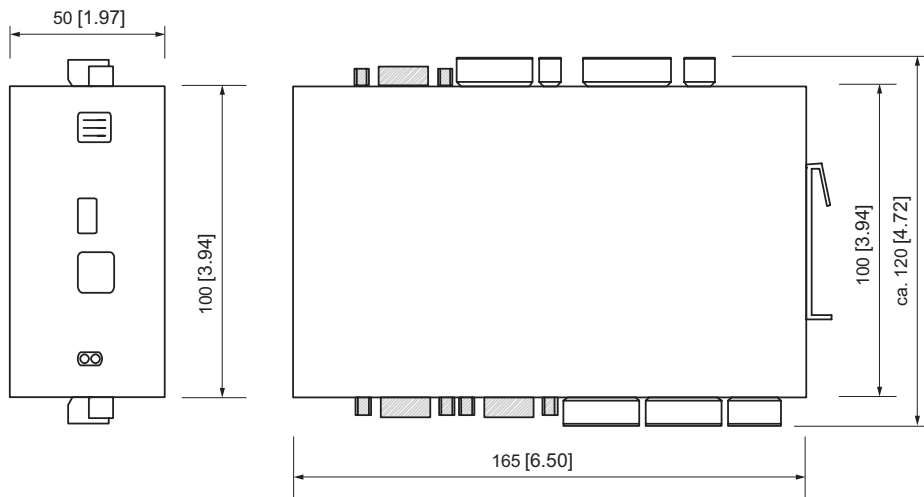

Control and diagnostic display – 8.SMCB.100

(further information can be found in the section accessories)

