

Absolute encoders – singleturn

Standard optical	Sendix S5858FS3 / S5878FS3 (shaft / hollow shaft)	PROFIsafe
-------------------------	----------------------------------------------------------	------------------



The optical absolute Sendix S58 PROFIsafe encoders are based on the new Kübler Industrial Ethernet encoder platform and are therefore already designed today for future Industry 4.0 concepts.

One example of this is the integrated web server: Features or adjustments can be implemented quickly and easily at any time.

As certified SIL3 / PLe encoders with redundant design and PROFINET interface, they support the PROFIsafe profile and are predestined for safety applications.

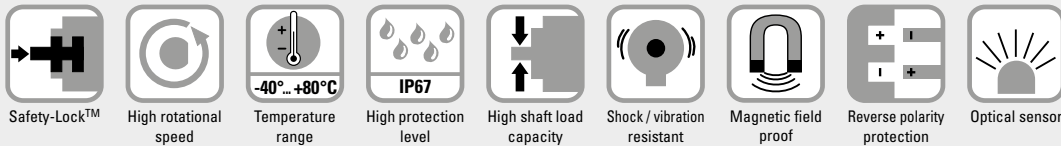

Reliable and safe

- **Robust**
Sturdy bearing construction in Safety-Lock™ Design for resistance against vibration and installation errors.
- **High resolution**
- Singleturn 15 bit (safe) or 24 bit (non safe).
- **Safe**
- SIL 3, performance level PLe, safety category Cat. 3.
- Transmission via safety telegrams 36/37, according to BP and XP.
- **100 % future-proof**
- Implement features and adaptations quickly and easily.
- Cyber Security update in preparation / High system availability, protection against misuse (acc. IEC 62443).

Latest PROFINET functionality

- PROFINET IO, RT, IRT allows integration in applications with different performance requirements.
- Supports the Isochronous Mode, can thus be implemented in networks for hard real-time requirements with clock cycles up to 500 µs.
- PROFINET v2.4.1, encoder profile V 4.2, PROFIsafe profile v2.6.1, PROFIdrive profile v4.2
- Ideal for highly synchronous applications, such as e. g. axis synchronization.
- Interoperability between many different control and drive manufacturers thanks to the PROFIdrive profile.
- Integrated web server for firmware update.

Absolute encoders – singleturn

Standard optical	Sendix S5858FS3 / S5878FS3 (shaft / hollow shaft)	PROFIsafe
-------------------------	----------------------------------------------------------	------------------

Order code	8.S5858FS3	.XXCN	.C111
Shaft version	Type	<div style="display: flex; justify-content: space-around; font-size: 0.8em;"> a b c d e </div>	

a Flange

- 1 = clamping flange, IP65 ø 58 mm [2.28"]
- 3 = clamping flange, IP67 ø 58 mm [2.28"]
- 2 = synchro flange, IP65 ø 58 mm [2.28"]
- 4 = synchro flange, IP67 ø 58 mm [2.28"]
- 5 = square flange, IP65 □ 63.5 mm [2.5"]
- 7 = square flange, IP67 □ 63.5 mm [2.5"]

b Shaft (ø x L), with flat

- 2 = 10 x 20 mm [0.39 x 0.79"]
- 5 = 12 x 20 mm [0.47 x 0.79"]
- 4 = 3/8" x 7/8"

Shaft (ø x L), with feather key DIN 6885 A-3x3x10

- A = 10 x 20 mm [0.39 x 0.79"]
- B = 12 x 20 mm [0.47 x 0.79"]
- C = 3/8" x 7/8"

c Interface / Supply voltage

- C = PROFINET IO / 10 ... 30 V DC

d Type of connection

- N = 3 x axial M12 connector, 4-pin

e Fieldbus profile

- C1 = PROFINET IO

Optional on request

- Ex 2/22 (only for variants with IP67)
- surface protection salt spray tested

Order code	8.S5878FS3	.XXCN	.C111
Hollow shaft	Type	<div style="display: flex; justify-content: space-around; font-size: 0.8em;"> a b c d e </div>	

a Flange

- 1 = with torque stop FS, flexible, IP65
- 2 = with torque stop FS, flexible, IP67
- 5 = with stator coupling FS, ø 63 mm [2.48"], IP65
- 6 = with stator coupling FS, ø 63 mm [2.48"], IP67
- 7 = with torque stop FS, rigid, IP65 (incl. torque pin FS)
- 8 = with torque stop FS, rigid, IP67 (incl. torque pin FS)

b Blind hollow shaft

(insertion depth max. 30 mm [1.18"])

- A = ø 10 mm [0.39"]
- B = ø 12 mm [0.47"]
- C = ø 14 mm [0.55"]
- D = ø 15 mm [0.59"]
- E = ø 3/8"
- F = ø 1/2"

c Interface / Supply voltage

- C = PROFINET IO / 10 ... 30 V DC

d Type of connection

- N = 3 x axial M12 connector, 4-pin

e Fieldbus profile

- C1 = PROFINET IO

Optional on request

- Ex 2/22 (only for variants with IP67)
- surface protection salt spray tested

Absolute encoders – singleturn

Standard optical		Sendix S5858FS3 / S5878FS3 (shaft / hollow shaft)	PROFIsafe
Mounting accessory for shaft encoders			Order no.
Bellows coupling FS	bellows coupling FS ø 25 mm [0.98"] for shaft 10 mm [0.39"]		8.0000.15FS.1010
	bellows coupling FS ø 25 mm [0.98"] for shaft 12 mm [0.47"]		8.0000.15FS.1212
Accessories			Order no.
Screw retention	Loctite 243, 5 ml		8.0000.4G05.0000
Cables and connectors			Order no.
Preassembled cables	M12 male connector with external thread, 4-pin, D coded, straight single-ended 2 m [6.56'] PUR cable	port 1 + port 2	05.00.6031.4411.002M
	M12 male connector with external thread, 4-pin, D coded, right-angle single-ended 2 m [6.56'] PUR cable	port 1 + port 2	05.00.6031.4511.002M
	M12 female connector with coupling nut, 4-pin, A coded, straight single-ended 2 m [6.56'] PUR cable	power supply	05.00.6061.6211.002M
	M12 female connector with coupling nut, 4-pin, A coded, right-angle single-ended 2 m [6.56'] PUR cable	power supply	05.00.6061.6311.002M
Connectors	M12 male connector with external thread, 4-pin, D coded, straight (metal)	port 1 + port 2	05.WASCSY4S
	M12 male connector with external thread, 4-pin, D coded, right-angle (metal)	port 1 + port 2	8.0000.5128.0000
	M12 female connector with coupling nut, 4-pin, A coded, straight (plastic)	power supply	05.B8141-0
	M12 female connector with coupling nut, 4-pin, A coded, right-angle (plastic)	power supply	05.B8241-0

Further Kübler accessories can be found at: [kuebler.com/accessories](https://www.kuebler.com/accessories)

Further Kübler cables and connectors can be found at: [kuebler.com/connection-technology](https://www.kuebler.com/connection-technology)

Absolute encoders – singleturn

Standard optical	Sendix S5858FS3 / S5878FS3 (shaft / hollow shaft)	PROFIsafe
-------------------------	----------------------------------------------------------	------------------

Technical data

Notes regarding “Functional Safety”

These encoders are suitable for use in safety-related systems up to SIL3 acc. to EN 61800-5-2 and PLe to EN ISO 13849-1 in conjunction with controllers or evaluation units, which possess the necessary functionality. Additional functions can be found in the operating manual.

Safety characteristics	
Classification	PLe / SIL3
System structure	2 channel (Kat. 3)
PFH_d value ¹⁾	$9,54 \times 10^{-10} \text{ h}^{-1}$
Mission time / Proof test interval	20 years
Relevant standards	EN ISO 13849-1:2015; EN ISO 13849-2:2012; EN 61800-5-2:2007

Mechanical characteristics	
Max. speed	9000 min ⁻¹ (short-term – 10 min) 6000 min ⁻¹ (continuous)
Starting torque at 20 °C [68 °F]	< 0.01 Nm
Moment of inertia	shaft version 3.0 x 10 ⁻⁶ kgm ² blind hollow shaft version 4.0 x 10 ⁻⁶ kgm ²
Load capacity of shaft	radial 80 N axial 40 N
Weight	approx. 0.45 kg [15.87 oz]
Protection acc. to EN 60529	IP65, IP67
Ambient temperature	-40 °C ... +80 °C [-40 °F ... +176 °F]
Material	shaft/hollow shaft stainless steel flange aluminum housing aluminum
Shock resistance acc. EN 60068-2-27	1000 m/s ² , 6 ms
Vibration resistance acc. EN 60068-2-6	100 m/s ² , 55 ... 2000 Hz

Electrical characteristics	
Supply voltage	10 ... 30 V DC
Power consumption (no load)	max. 250 mA
Reverse polarity protection of the supply voltage (+V)	yes
Smallest safe measuring step	158,4 arcsec (0,044° / 4 increments)
Lowest safe speed	4 rpm ($\sigma_v < 0,5 \%$)

Approvals	
UL compliant in accordance with	File no. E224618
CE compliant in accordance with	
EMC Directive	2014/30/EU
RoHS Directive	2011/65/EU
ATEX Directive	2014/34/EU (for Ex 2/22 variants)
Machinery Directive	2006/42/EG

1) The specified value is based on a diagnostic coverage of 99 %, that must be achieved with an encoder evaluation unit. The encoder evaluation unit must meet at least the requirements for SIL3.

Absolute encoders – singleturn

Standard optical	Sendix S5858FS3 / S5878FS3 (shaft / hollow shaft)	PROFIsafe
-------------------------	----------------------------------------------------------	------------------

Interface characteristics PROFIsafe

General information		Adjustable parameters	
Protocol	PROFINET IO / PROFIsafe	<ul style="list-style-type: none"> • Preset • Counting direction • Resolution per revolution - MUR • Unit speed • IP address • Total resolution - TMR • Position format • Speed reference value 	<ul style="list-style-type: none"> • Scaling • Device name • F-Destination Address • I&M 0...3 Parameter • Alarm behavior • Parameter write protection • Parameter initialization
Classifications	RT Class 3 (IRT) Conformance Class C Application Class 6 Encoder Class 4 / S2 Netload Class III		

Resolution		PROFIsafe characteristics	
Resolution Singleturn (MUR)		<ul style="list-style-type: none"> • I&M 0 ... 4 • standard telegrams (81, 82, 83, 84, 86, 88) • standard safety telegrams (36, 37) BP and XP • IRT up to 500 µs • RT Safe up to 4 ms 	<ul style="list-style-type: none"> • Isochronous Mode • MRP • LLDP • PDEV • SNMP • FSU
scalable safe	1 ... 32 768 (15 bit)		
scalable non-safe	1 ... 16 777 216 (24 bit)		
default	8 192 (13 bit)		

Process data	
<ul style="list-style-type: none"> • Position (Safe / Non-Safe) • Speed (Safe / Non-Safe) 	<ul style="list-style-type: none"> • Failure • Warnings

Terminal assignment bus

Interface	Type of connection	Function	M12 connector, 4-pin					Diagram
			Signal:	Transmit data+	Receive data+	Transmit data -	Receive data -	
C	N (3 x M12 connector)	Bus Port 1	Signal:	Transmit data+	Receive data+	Transmit data -	Receive data -	
			Abbreviation:	TxD+	RxD+	TxD-	RxD-	
			Pin:	1	2	3	4	
		Power supply	Signal:	Voltage +	-	Voltage -	-	
			Abbreviation:	+ V	-	0 V	-	
			Pin:	1	2	3	4	
		Bus Port 2	Signal:	Transmit data+	Receive data+	Transmit data -	Receive data -	
			Abbreviation:	TxD+	RxD+	TxD-	RxD-	
			Pin:	1	2	3	4	

Rear side connections and display elements

①	Ethernet Port – Link 2	
②	Supply voltage	
③	Cover screw	
④	Ethernet Port – Link 1	
⑤	Link 2	flashes yellow when connected
⑥	BF – Bus Failure	displays network errors *)
⑦	SF – System Failure	displays system errors *)
⑧	ENC	shows status of encoder *)
⑨	Link 1	flashes yellow when connected

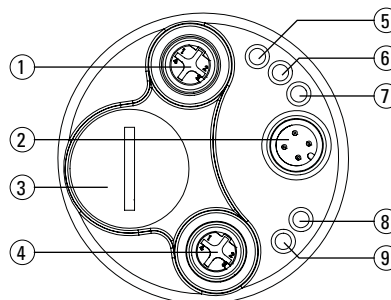

*) see manual

Absolute encoders – singleturn

Standard optical

Sendix S5858FS3 / S5878FS3 (shaft / hollow shaft)

PROFIsafe

Technology in detail

Clock synchronicity – Isochronous Real Time (IRT) in position sensor technology

In general, for time-critical applications, focus is set on very short sensor cycle times. However, in order to achieve high control performance, simply accelerating data acquisition and processing by shortest cycle times is not sufficient. All sensors and actuators are to operate according to the same clock.

This is achieved thanks to a clock used for the whole network, defined by the controller. This transmit clock cycle (IRT clock) is however not necessarily the clock cycle used for process data exchange. Another cycle (application cycle) is used for this purpose, which can also be defined by the customer controller. The illustration below represents the connection between the different clock cycles.

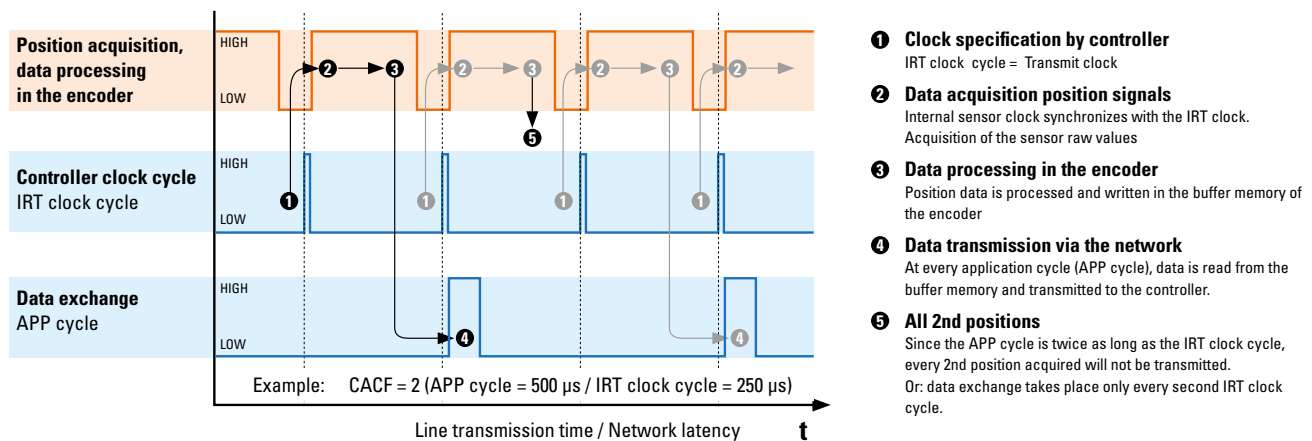

When receiving the IRT clock signal, the sensor starts reading its current measured point. This raw value is processed internally (e.g. scaling, speed calculation, etc.) and stored in a buffer memory.

The buffer memory is read at every application cycle. If it contains a value, this value is transmitted to the controller via the network.

If the application cycle is a multiple of the IRT clock cycle, it may happen that the buffered process data is not sent directly, but is overwritten, because, even though this data is acquired with every IRT clock cycle, it is sent only with every application cycle.

The ratio between application cycle and IRT clock cycle represents the CACF (Controller Application Cycle Factor).

In this example, the CACF = 2. This indicates that only every 2nd acquired position will be transmitted to the controller.

The described methodology guarantees a determinism: since the controller defines a clock cycle for the whole network, this allows ensuring that all measured values transmitted by the sensors to the controller are never older than the selected IRT cycle! Therefore, all downstream actuators can always be regulated on the basis of the latest available measured values.

PROFIsafe encoders – Data flow of safe and non-safe position values

In safety-related applications, safe process data is required for sequence control, which must be detected at least redundantly and provided reliably.

With high performance controllers, it is possible to compare the two measured values against each other and thus generate safe process data. This data can be directly evaluated, calculated or scaled in the sensor before it is transferred.

Since there are restrictions on the resolution and transmission speed for safe process data due to the comparison of the redundant measured values, it can happen that non-safe process data is also required in addition to the safe data, for example to transmit a high-resolution position to the following periphery.

The safe process data is then sent via the same infrastructure as the non-safe process data according to the so-called „black channel“ principle.

From the point of view of the protocol used, this takes place in a separate area (safe slot) that is distinct from the non-safe area (non-safe slot). Both transmissions can run parallel to each other.

Unlike with safe data, the non-safe process data can also be sent at a specified clock cycle of the controller (isochronous mode).

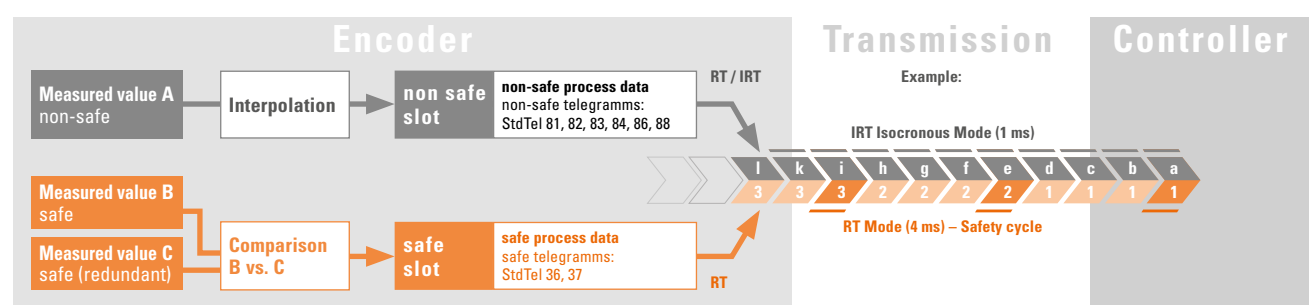

Absolute encoders – singleturn

Standard optical	Sendix S5858FS3 / S5878FS3 (shaft / hollow shaft)	PROFlsafe
-------------------------	----------------------------------------------------------	------------------

Dimensions shaft version

Dimensions in mm [inch]

Clamping flange, \varnothing 58 [2.28]

Flange type 1 + 3

- 1 3 x M3, 6 [0.24] deep
- 2 3 x M4, 8 [0.31] deep

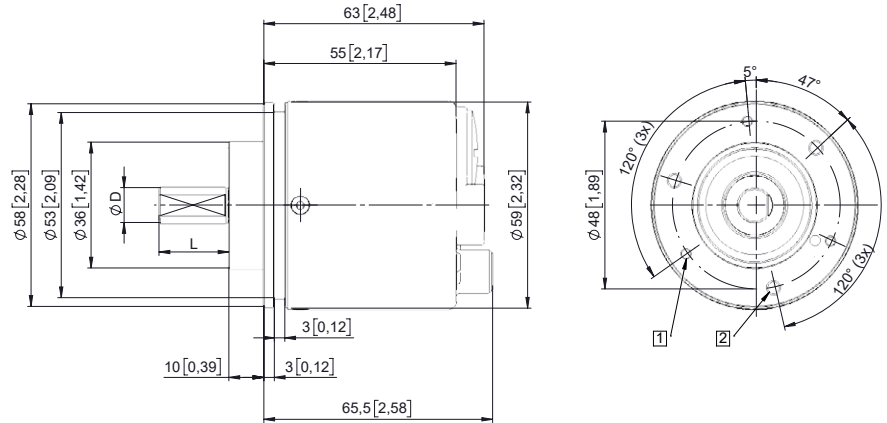

D	Fit	L
10 [0.39]	h7	20 [0.79]
12 [0.47]	h7	20 [0.79]
3/8"	h7	7/8"

Synchro flange, \varnothing 58 [2.28]

Flange type 2 + 4

- 1 3 x M4, 8 [0.31] deep

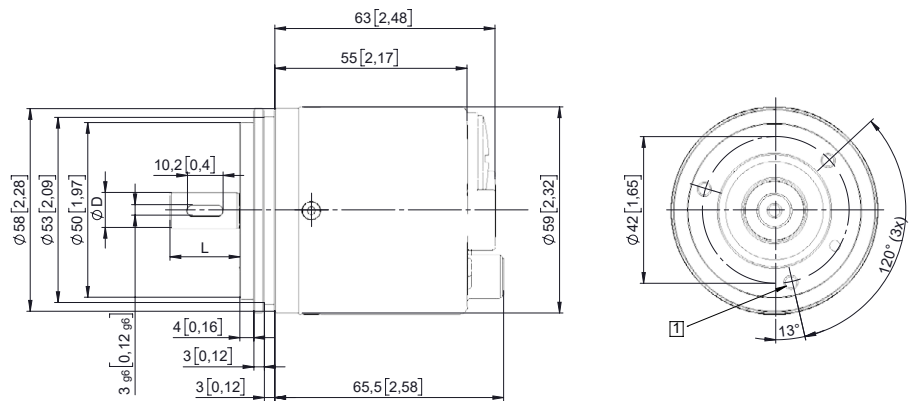

D	Fit	L
10 [0.39]	h7	20 [0.79]
12 [0.47]	h7	20 [0.79]
3/8"	h7	7/8"

Square flange, \square 63.5 [2.5]

Flange type 5 + 7

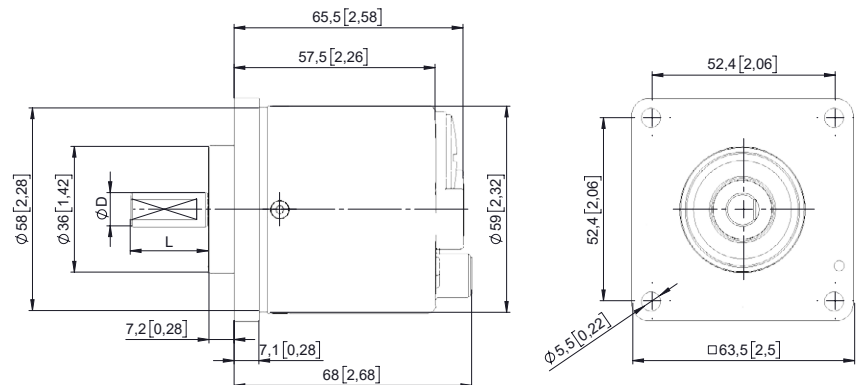

D	Fit	L
10 [0.39]	h7	20 [0.79]
12 [0.47]	h7	20 [0.79]
3/8"	h7	7/8"

Absolute encoders – singleturn

Standard optical

Sendix S5858FS3 / S5878FS3 (shaft / hollow shaft)

PROFlsafe

Dimensions hollow shaft version

Dimensions in mm [inch]

Flange with torque stop FS, flexible Flange type 1 + 2

1 Recommended torque for the clamping ring 2.5 Nm

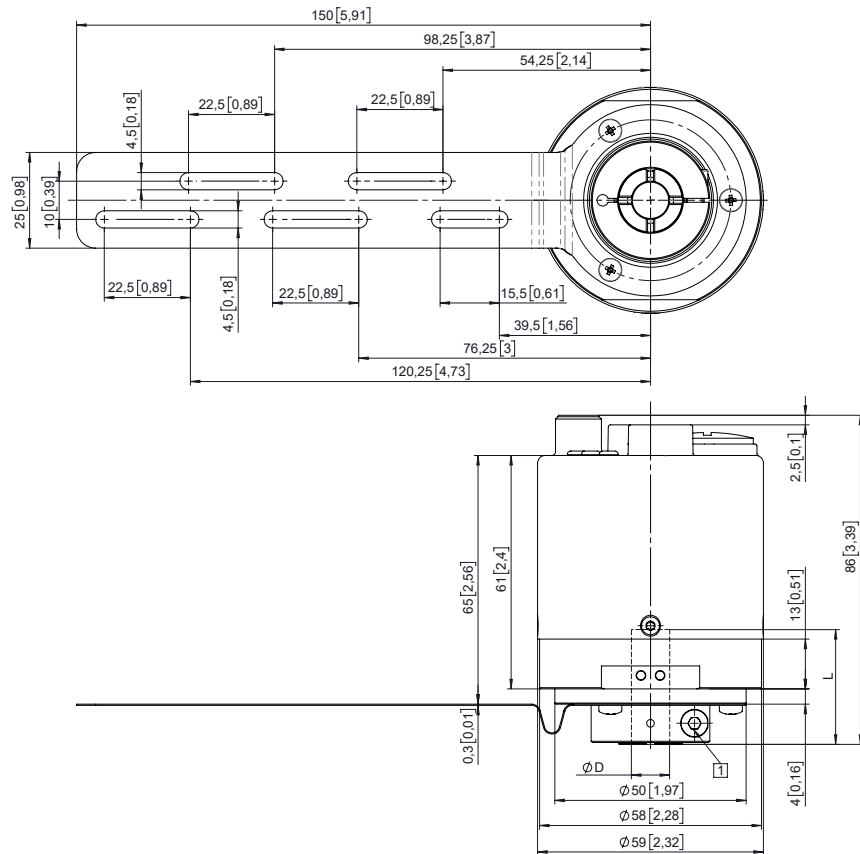

D	Fit	L
10 [0.39]	H7	30 [1.18]
12 [0.47]	H7	30 [1.18]
14 [0.55]	H7	30 [1.18]
15 [0.59]	H7	30 [1.18]
3/8"	H7	30 [1.18]
1/2"	H7	30 [1.18]

L = insertion depth max. blind hollow shaft

Flange with stator coupling FS, Ø 63 [2.48] Flange type 5 + 6

1 Recommended torque for the clamping ring 2.5 Nm

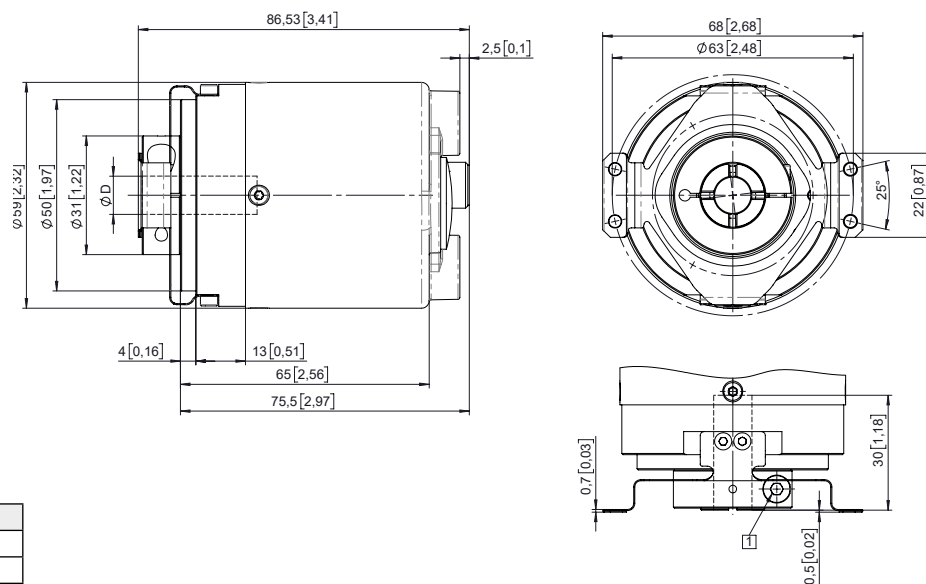

D	Fit	L
10 [0.39]	H7	30 [1.18]
12 [0.47]	H7	30 [1.18]
14 [0.55]	H7	30 [1.18]
15 [0.59]	H7	30 [1.18]
3/8"	H7	30 [1.18]
1/2"	H7	30 [1.18]

L = insertion depth max. blind hollow shaft

Absolute encoders – singleturn

Standard optical	Sendix S5858FS3 / S5878FS3 (shaft / hollow shaft)	PROFlsafe
-------------------------	----------------------------------------------------------	------------------

Dimensions hollow shaft version

Dimensions in mm [inch]

Flange with torque stop FS, rigid Flange type 7 + 8

1 Recommended torque for the clamping ring 2.5 Nm

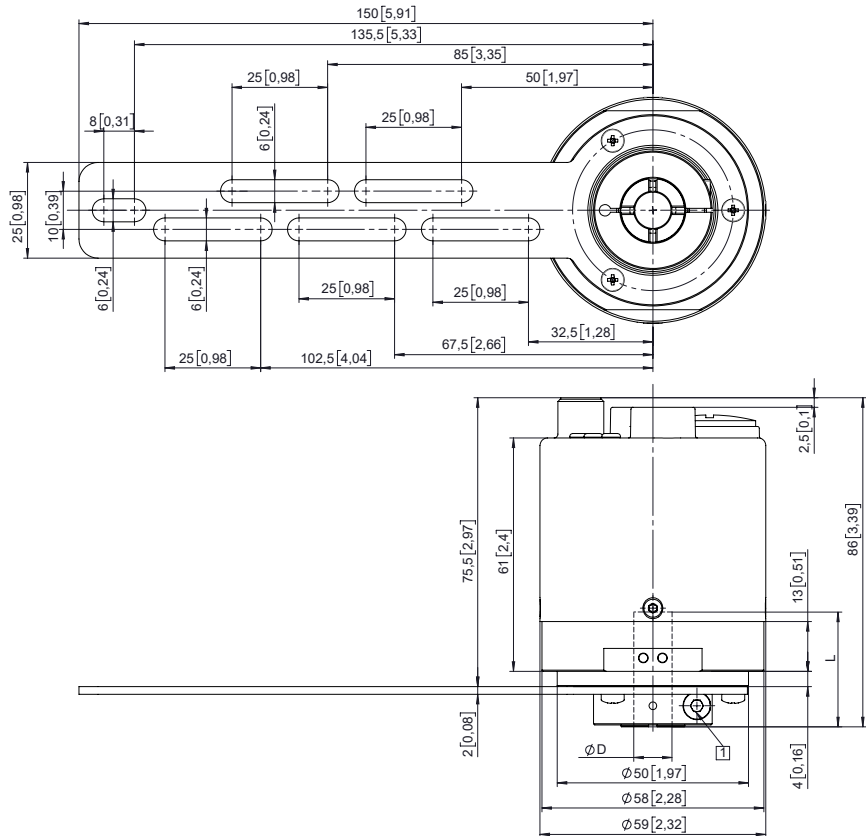

D	Fit	L
10 [0.39]	H7	30 [1.18]
12 [0.47]	H7	30 [1.18]
14 [0.55]	H7	30 [1.18]
15 [0.59]	H7	30 [1.18]
3/8"	H7	30 [1.18]
1/2"	H7	30 [1.18]

L = insertion depth max. blind hollow shaft

Torque pin with rectangular sleeve with M4 thread
(included in scope of delivery)

