

# Measuring wheel systems

System components	Measuring wheels	Different coatings, different circumferences
-------------------	------------------	--



Measuring wheels for measuring the length of products in movement, e.g. in the paper, metal, textile, wood or plastic industry.

Different wheel surfaces to meet the requirements of the various surfaces of the product to be measured – different circumferences, designed for use with Kübler encoders, available for metric and imperial systems.

The measuring wheels can be easily combined with Kübler Sendix encoders and suitable encoder brackets.

The brackets are equipped with spring elements to ensure optimum contact pressure of the measuring wheel on the measuring surface and as compensation for unevenness and assembly tolerances in the application.

In addition, the measuring wheels can only be used for in-house purposes which are not subject to the stipulations of the German calibration code.

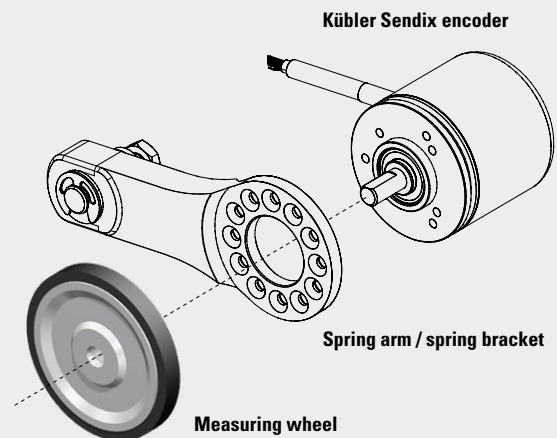

## Measuring wheel coatings



**Diamond knurl**  
(aluminum)

**Plastic smooth**  
(polyurethane)

**Tufted rubber**  
(polyurethane)

**O-ring**  
(NBR70)







**Double O-ring**  
(NBR70)

**Plastic corrugated**  
(polyurethane)

# Measuring wheel systems

<b>System components</b>	<b>Measuring wheels</b>	<b>Different coatings, different circumferences</b>
--------------------------	-------------------------	---

## Measuring wheel coatings

Selection of the measuring wheel coatings according to the surface of the measured material							
		diamond knurl (aluminum)	rubber / plastic, smooth (polyurethane)	tufted rubber (polyurethane)	O-ring (NBR70)	Double O-ring (NBR70)	plastic, corrugated (polyurethane)
Surface of the measured material	Profile measuring wheel	1	2 / 4	6	7	8	9
Cardboard		✓	✓	✓	✓	✓	✓
Wood		✓	✓	✓	✓	✓	✓
Textile		✓	✓	✓	✓	✓	✓
Plastic (e.g. PVC, PE, ...)		-	✓	✓	✓	✓	✓
Paper		-	✓	✓	✓	✓	✓
Wire, greased metals, steel profiles, leather		-	✓	-	-	-	-
Carpet, cables, nonwoven		-	-	✓	-	-	-
Greased metals, glass, floor coverings		-	-	-	-	-	✓
Painted surfaces		-	✓	-	✓	✓	✓
Rubber, soft plastic		✓	-	-	-	-	-
Surface available for measuring wheel circumference:							
	<b>100 mm</b>	✓	✓	-	-	-	-
	<b>200 mm</b> (tread 5.5 mm)	✓	✓	-	✓	-	-
	<b>200 mm</b> (tread 12 mm)	✓	✓	✓	✓	✓	✓
	<b>300 mm</b>	✓	✓	✓	✓	✓	✓
	<b>500 mm</b>	✓	✓	✓	-	-	✓
	<b>6"</b> (tread 5.5 mm)	✓	✓	-	✓	-	-
	<b>6"</b> (tread 12 mm)	✓	-	-	-	-	-
	<b>12"</b>	✓	✓	✓	✓	✓	✓

Technical specifications of the measuring wheels:

Max. lateral run-out: 0.2 mm  
 Max. radial run-out: 0.2 mm  
 Material: Aluminum  
 Temperature range: -30 °C ... +80 °C [-22 °F ... +176 °F]

# Measuring wheel systems

System components	Measuring wheels	Different coatings, different circumferences
-------------------	------------------	--

<b>Order code</b>	<b>8.0000</b>	<b>. 3</b>	<b>XXX</b>	<b>. 00</b>	<b>XX</b>
<b>Measuring wheel</b>			<b>a</b>		<b>b</b>

Measuring wheel circumference	suitable for measuring wheel /measuring wheel system					Tread width	Profil measuring wheels	Coating	Coating hardness Shore A	Wheel no. <b>a</b>	Weight	Standard bore <b>b</b> <sup>1)</sup>
	MWE11	MWE2x	MWE3x	MWE4x	MWE6x							
100 mm	✓	-	-	-	-	9.5 mm	1	diamond knurl (aluminum)	-	113	15.0 g	06 = 6 mm [0.24"]
							2	natural rubber	60	123	16.0 g	
200 mm	-	✓	✓	-	-	5.5 mm	1	diamond knurl (aluminum)	-	215	38.5 g	06 = 6 mm [0.24"]
							4	plastic smooth (polyurethane)	70	245	41.5 g	
							7	O-ring (NBR70)	70	275	36.0 g	
						12 mm	1	diamond knurl (aluminum)	-	217	60.0 g	06 = 6 mm [0.24"] 10 = 10 mm [0.39"]
				✓	✓		4	plastic smooth (polyurethane)	90	247	60.0 g	
							6	tufted rubber (polyurethane)	60	267	60.0 g	
							7	O-ring (NBR70)	70	277	60.0 g	
							8	double O-ring (NBR70)	70	287	60.0 g	
					9	plastic corrugated (polyurethane)	90	297	60.0 g			
300 mm	-	-	-	✓	✓	12 mm	1	diamond knurl (aluminum)	-	317	115.0 g	10 = 10 mm [0.39"]
							4	plastic smooth (polyurethane)	90	347	115.0 g	
							6	tufted rubber (polyurethane)	60	367	115.0 g	
							7	O-ring (NBR70)	70	377	115.0 g	
							8	double O-ring (NBR70)	70	387	117.0 g	
							9	plastic corrugated (polyurethane)	90	397	115.0 g	
500 mm	-	-	-	✓	✓	25 mm	1	diamond knurl (aluminum)	-	517	505.0 g	10 = 10 mm [0.39"]
							4	plastic smooth (polyurethane)	90	547	501.0 g	
							6	tufted rubber (polyurethane)	60	567	483.0 g	
							9	plastic corrugated (polyurethane)	90	597	501.0 g	
6"	-	✓	-	-	-	5.5 mm	1	diamond knurl (aluminum)	-	615	25.0 g	06 = 6 mm [0.24"]
							4	plastic smooth (polyurethane)	70	645	23.5 g	
						7	O-ring (NBR70)	70	675	21.5 g		
	-	-	-	-	-	12 mm	1	diamond knurl (aluminum)	-	617	60.0 g	
12"	-	-	-	✓	✓	12 mm	1	diamond knurl (aluminum)	-	717	115.0 g	10 = 10 mm [0.39"]
							4	plastic smooth (polyurethane)	90	747	115.0 g	
							6	tufted rubber (polyurethane)	60	767	115.0 g	
							7	O-ring (NBR70)	70	777	115.0 g	
							8	double O-ring (NBR70)	70	787	117.0 g	
							9	plastic corrugated (polyurethane)	90	797	115.0 g	

**Stock types**

8.0000.3215.0006	8.0000.3275.0006	8.0000.3597.0010
8.0000.3217.0010	8.0000.3347.0010	8.0000.3615.0006
8.0000.3245.0006	8.0000.3377.0010	8.0000.3645.0006
8.0000.3247.0010	8.0000.3547.0010	8.0000.3675.0006
8.0000.3267.0010	8.0000.3567.0010	

1) Other bore diameters on request

# Measuring wheel systems

## System components      Measuring wheels      Different coatings, different circumferences

### Dimensions

Dimensions in mm [inch]

**Measuring wheel circumference 100 mm ±0,1 mm**

**Tread width 9,5 mm**

**No. 113**  
diamond knurl  
(aluminum)

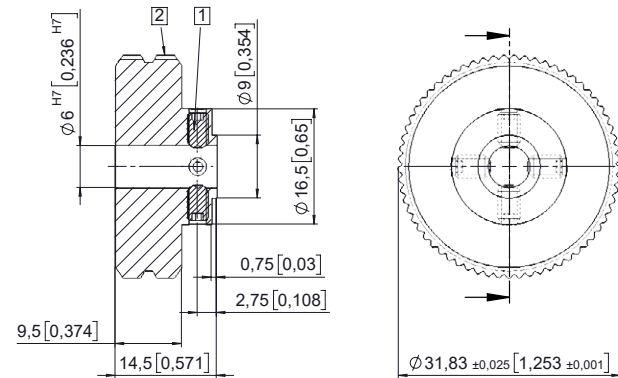

**No. 123**  
natural rubber

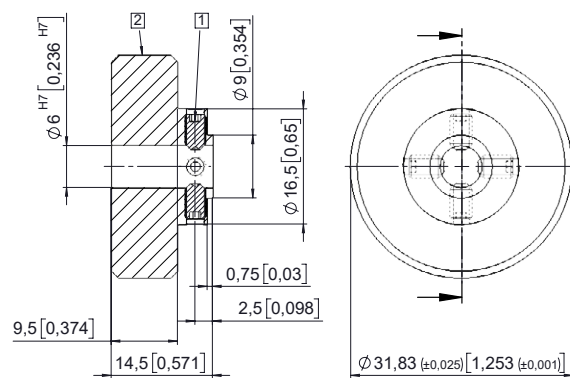

- 1 screw M3x5 ISO4029 (4x)
- 2 diamond knurl

- 1 screw M4x6 ISO4029
- 2 natural rubber, Shore 60

**Measuring wheel circumference 200 mm ±0,2 mm**

**Tread width 5,5 mm**

- 1 screw M4x6 ISO4029

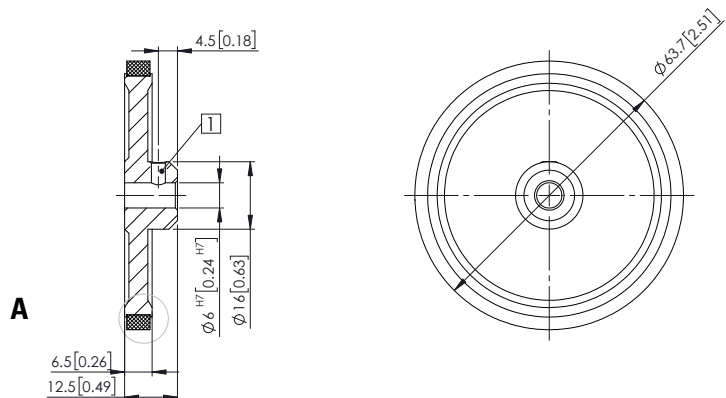

**A** for measuring wheel no. (with coating):

**No. 215**  
diamond knurl  
(aluminum)

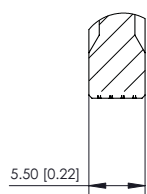

**No. 245**  
plastic smooth  
(polyurethane)

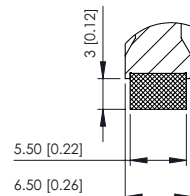

**No. 275**  
O-ring  
(NBR)

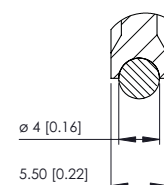

# Measuring wheel systems

System components	Measuring wheels	Different coatings, different circumferences
-------------------	------------------	--

## Dimensions

Dimensions in mm [inch]

**Measuring wheel circumference 200 mm** ±0,2 mm (with O-ring ±0,5 mm)

**Tread width 12 mm**

Bore for shaft 10 mm (also with bore 6 mm)

1 screw M4x6 ISO4029

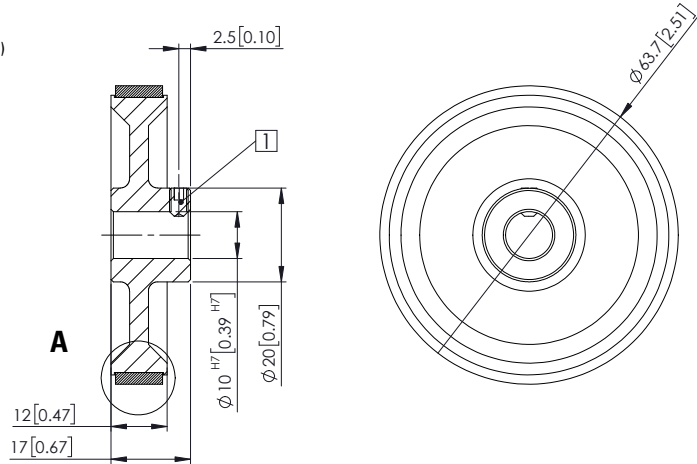

**A** for measuring wheel no. (with coating):

**No. 217**  
diamond knurl  
(aluminum)

**No. 247**  
plastic smooth  
(polyurethane)

**No. 267**  
tufted rubber  
(polyurethane)

**No. 277**  
O-ring  
(NBR)

**No. 287**  
double O-ring  
(NBR)

**No. 297**  
plastic corrugated  
(polyurethane)

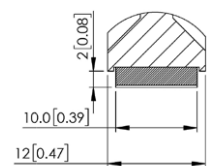
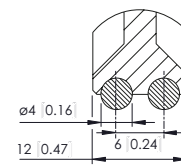
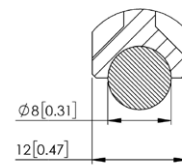
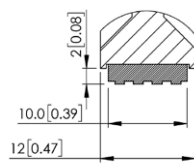
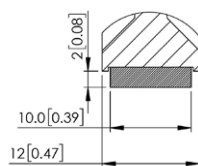
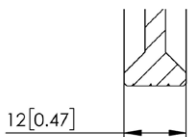

**Measuring wheel circumference 300 mm** ±0,2 mm (with O-ring ±0,5 mm)

**Tread width 12 mm**

1 screw M4x6 ISO4029

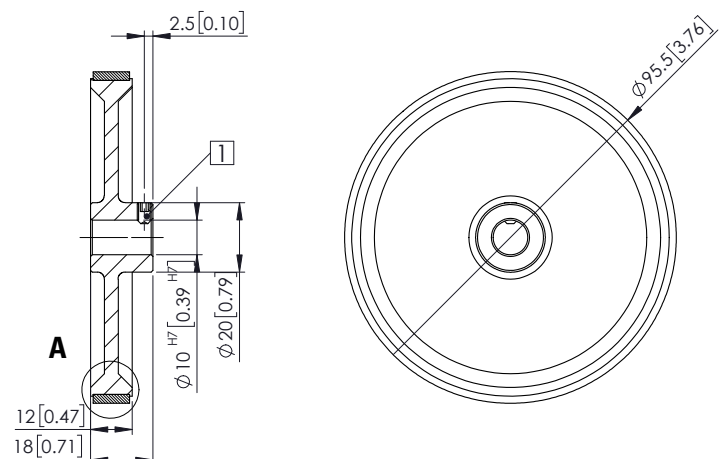

**A** for measuring wheel no. (with coating):

**No. 317**  
diamond knurl  
(aluminum)

**No. 347**  
plastic smooth  
(polyurethane)

**No. 367**  
tufted rubber  
(polyurethane)

**No. 377**  
O-ring  
(NBR)

**No. 387**  
double O-ring  
(NBR)

**No. 397**  
plastic corrugated  
(polyurethane)

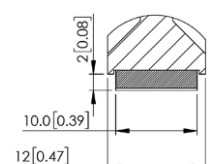
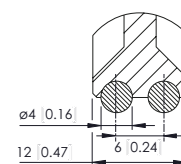
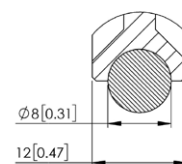
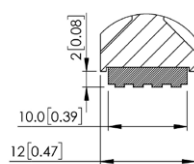
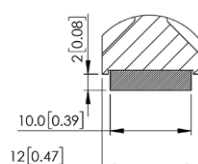
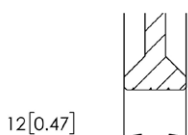

# Measuring wheel systems

System components	Measuring wheels	Different coatings, different circumferences
-------------------	------------------	--

## Dimensions

Dimensions in mm [inch]

**Measuring wheel circumference 500 mm ±1,0 mm**  
**Tread width 25 mm**

1 screw M5x10 ISO4029

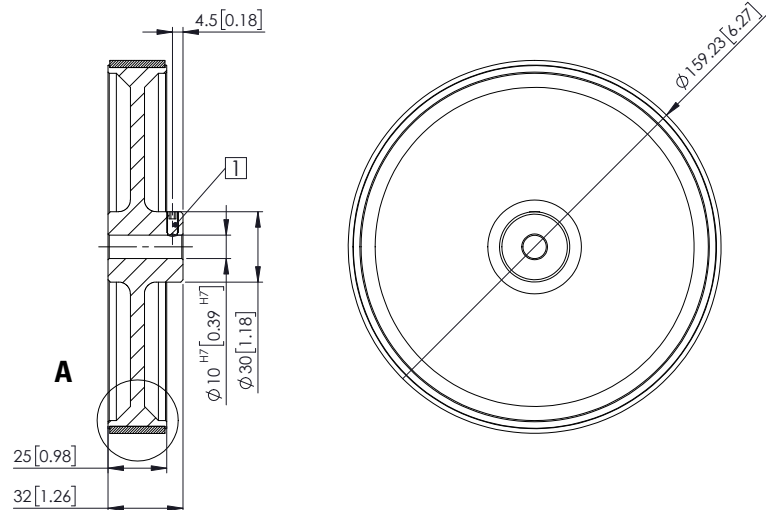

**A** for measuring wheel no. (with coating):

**No. 517**  
diamond knurl  
(aluminum)

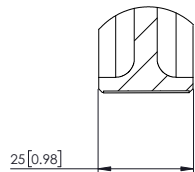

**No. 547**  
plastic smooth  
(polyurethane)

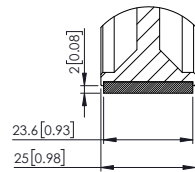

**No. 567**  
tufted rubber  
(polyurethane)

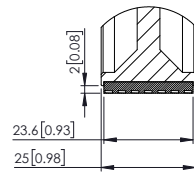

**No. 597**  
plastic corrugated  
(polyurethane)

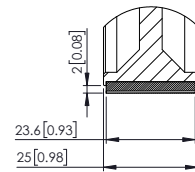

**Measuring wheel circumference 6" ±0,2 mm**  
**Tread width 5,5 mm**

1 screw M4x6 ISO4029

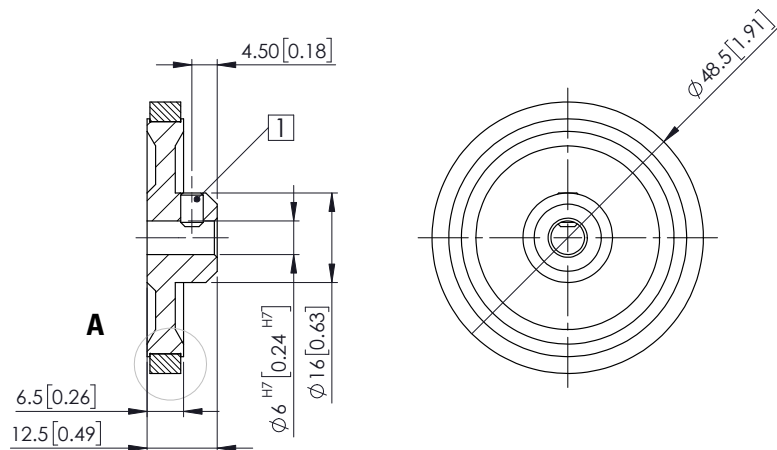

**A** for measuring wheel no. (with coating):

**No. 615**  
diamond knurl  
(aluminum)

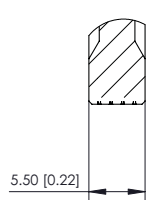

**No. 645**  
plastic smooth  
(polyurethane)

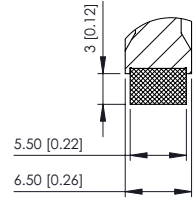

**No. 675**  
O-ring  
(NBR)

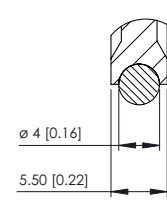

# Measuring wheel systems

System components	Measuring wheels	Different coatings, different circumferences
-------------------	------------------	--

## Dimensions

Dimensions in mm [inch]

**Measuring wheel circumference 6" ±0,2 mm**  
**Tread width 12 mm**

1 screw M4x6 ISO4029

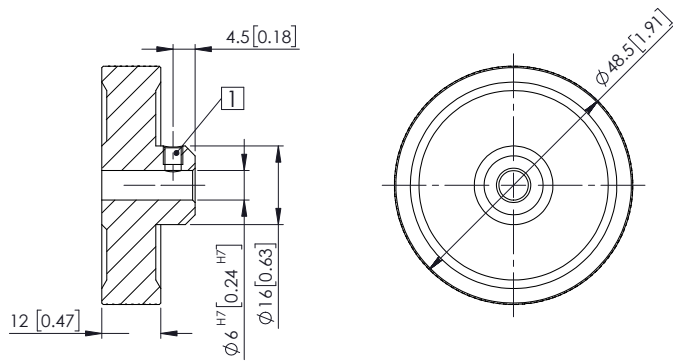

**Measuring wheel circumference 12" ±0,2 mm (with O-ring ±0,5 mm)**  
**Tread width 12 mm**

1 screw M4x6 ISO4029

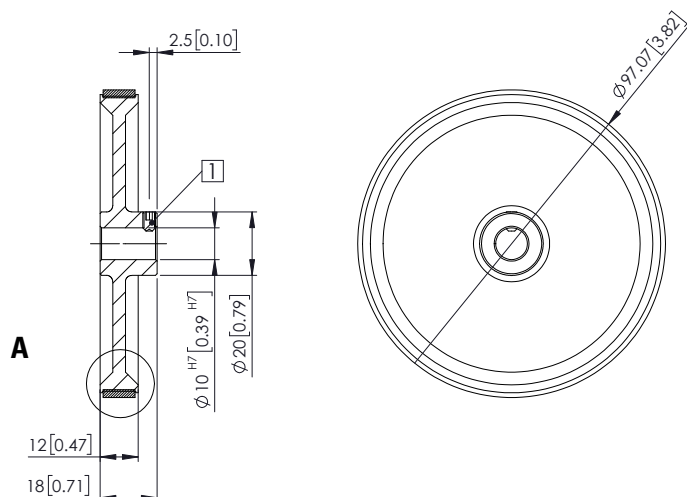

**A** for measuring wheel no. (with coating):

No. 717 diamond knurl (aluminum)	No. 747 plastic smooth (polyurethane)	No. 767 tufted rubber (polyurethane)	No. 777 O-ring (NBR)	No. 787 double O-ring (NBR)	No. 797 plastic corrugated (polyurethane)
12 [0.47]	10.0 [0.39] 2 [0.08] 12 [0.47]	10.0 [0.39] 2 [0.08] 12 [0.47]	Ø8 [0.31] 12 [0.47]	Ø4 [0.16] 12 [0.47] 6 [0.24]	10.0 [0.39] 2 [0.08] 12 [0.47]