

Incremental encoders

Compact optical	Sendix Base KIS40 / KIH40 (shaft / hollow shaft)	Push-pull / RS422 / Open collector
------------------------	---	---

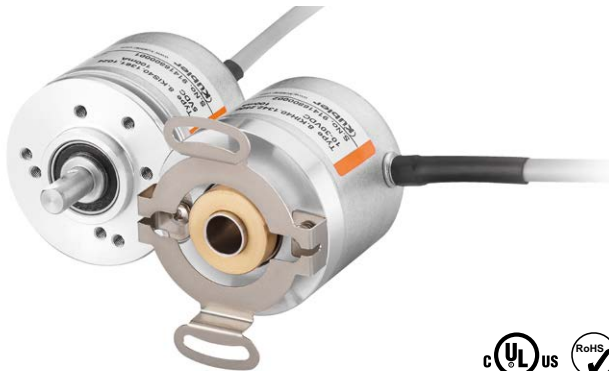

The incremental encoders type Sendix Base KIS40 / KIH40 with optical sensor technology have been designed for highest cost-effectiveness. They are available with a resolution of up to 2560 pulses per revolution.

They are particularly suitable for tight mounting spaces and small machines and appliances.



Safety-Lock™	High rotational speed	Temperature range	Shock / vibration resistant	Short-circuit proof	Reverse polarity protection	Magnetic field proof	Optical sensor

Compact and robust

- Only 40 mm outer diameter.
- Ideally suited for use where space is tight.
- Sturdy bearing construction in Safety Lock™ design.
- Safe commissioning: reverse polarity protection and short-circuit proof.

Flexible

- Maximum resolution of 2560 pulses per revolution.
- Supply voltage 5 V DC, 10 ... 30 V DC or 5 ... 30 V DC.
- Push-pull, RS422 or open collector
- Radial or axial cable.

Order code	8.KIS40 . 1 XXX . XXXX . P000¹⁾ X¹⁾
Shaft version	Type a b c d e f

a Flange

1 = clamping-synchro flange, ø 40 mm [1.57"]

b Shaft (ø x L)

3 = ø 6 x 12.5 mm [0.24 x 0.49"], with flat
 5 = ø 1/4" x 12.5 mm [1/4" x 0.49"], with flat
 6 = ø 8 x 12.5 mm [0.32 x 0.49"], with flat

c Output circuit / supply voltage

3 = open collector NPN (with inverted signal) / 10 ... 30 V DC
 4 = push-pull (with inverted signal) / 10 ... 30 V DC
 6 = RS422 (with inverted signal) / 5 V DC
 7 = open collector NPN (without inverted signal) / 10 ... 30 V DC
 8 = push-pull (without inverted signal) / 10 ... 30 V DC
 A = open collector NPN (with inverted signal) / 5 ... 30 V DC
 B = push-pull (with inverted signal) / 5 ... 30 V DC
 C = RS422 (with inverted signal) / 5 ... 30 V DC

d Type of connection

1 = axial cable, 2 m [6.56'] PVC
 2 = radial cable, 2 m [6.56'] PVC
 4 = radial cable, 0.5 m [1.64'] PVC, with M12 connector, 5-pin
 6 = radial cable, 0.5 m [1.64'] PVC, with M12 connector, 8-pin
 A = axial cable, special length PVC *)
 B = radial cable, special length PVC *)

*) Available special lengths (connection types A, B):
 3, 5, 8, 10, 15 m [9.84, 16.40, 26.25, 32.80, 49.21']
 order code expansion .XXXX = length in dm
 e.g.: 8.KIS40.134A.1024. (P000X.) 0050 (for cable length 5 m)

e Pulse rate

10, 25, 50, 60, 100, 120, 150, 200, 250, 360, 400, 500, 512, 600, 1000, 1024, 1500, 1800, 2000, 2048, 2500, 2560
 (e.g. 500 pulses => 0500)

f Special connector pin configuration

7 = see page 4
 9 = see page 4
 A = see page 4

Optional on request
 - other pulse rates

1) Is only necessary when a special connector pin configuration is required.

Incremental encoders

Compact optical	Sendix Base KIS40 / KIH40 (shaft / hollow shaft)	Push-pull / RS422 / Open collector
------------------------	---	---

Order code	8.KIH40	.XXXX	.XXXX	.P000¹⁾	X¹⁾
Hollow shaft	Type	a b c d	e	f	g

a Flange
 2 = with spring element, long
 5 = with stator coupling, ø 46 mm [1.81"]

b Blind hollow shaft (insertion depth max. 18 mm [0.71"])
 2 = ø 6 mm [0.24"]
 4 = ø 8 mm [0.32"]
 3 = ø 1/4"

c Output circuit / supply voltage
 3 = open collector NPN (with inverted signal) / 10 ... 30 V DC
 4 = push-pull (with inverted signal) / 10 ... 30 V DC
 6 = RS422 (with inverted signal) / 5 V DC
 7 = open collector NPN (without inverted signal) / 10 ... 30 V DC
 8 = push-pull (without inverted signal) / 10 ... 30 V DC
 A = open collector NPN (with inverted signal) / 5 ... 30 V DC
 B = push-pull (with inverted signal) / 5 ... 30 V DC
 C = RS422 (with inverted signal) / 5 ... 30 V DC

d Type of connection
 1 = axial cable, 2 m [6.56'] PVC
 2 = radial cable, 2 m [6.56'] PVC
 4 = radial cable, 0.5 m [1.64'] PVC, with M12 connector, 5-pin
 6 = radial cable, 0.5 m [1.64'] PVC, with M12 connector, 8-pin
 A = axial cable, special length PVC *)
 B = radial cable, special length PVC *)

*) Available special lengths (connection types A, B):
 3, 5, 8, 10, 15 m [9.84, 16.40, 26.25, 32.80, 49.21']
 order code expansion .XXXX = length in dm
 ex.: 8.KIH40.544A.1024. (P000X.) **0050** (for cable length 5 m)

e Pulse rate
 10, 25, 50, 60, 100, 120, 150, 200, 250, 360, 400, 500, 512, 600, 1000,
 1024, 1500, 1800, 2000, 2048, 2500, 2560
 (e.g. 500 pulses => 0500)

f Special connector pin configuration
 7 = see page 4
 9 = see page 4
 A = see page 4

Optional on request
 - other pulse rates

Mounting accessory for shaft encoders	Order no.
Coupling bellows coupling ø 15 mm [0.59"] for shaft 6 mm [0.24"]	8.0000.1202.0606

Further Kübler accessories can be found at: kuebler.com/accessories

1) Is only necessary when a special connector pin configuration is required

Incremental encoders

Compact optical	Sendix Base KIS40 / KIH40 (shaft / hollow shaft)	Push-pull / RS422 / Open collector
------------------------	---	---

Technical data

Electrical characteristics			
Output circuit	RS422 (TTL comp.)	Push-pull ¹⁾ (7272 comp.)	Open collector NPN (7273)
Supply voltage	5 V DC (±5 %) / 5 ... 30 V DC	10 ... 30 V DC / 5 ... 30 V DC	10 ... 30 V DC / 5 ... 30 V DC
Power consumption with inverted signal (no load)	typ. 40 mA max. 90 mA / max. 165 mA	typ. 50 mA max. 100 mA	100 mA
Permissible load / channel	max. +/- 20 mA	max. +/- 20 mA	20 mA sink at 30 V DC
Pulse frequency	max. 250 kHz	max. 250 kHz	max. 250 kHz
Signal level	HIGH min. 2.5 V LOW max. 0.5 V	min. +V - 2.0 V max. 0.5 V	
Rising edge time t_r	max. 200 ns	max. 1 µs	
Falling edge time t_f	max. 200 ns	max. 1 µs	
Short circuit proof outputs ²⁾	yes ³⁾	yes	yes
Reverse polarity protection of the supply voltage	no/yes	yes	yes

Mechanical characteristics	
Maximum speed	4500 min ⁻¹
Mass moment of inertia	approx. 0.2 x 10 ⁻⁶ kgm ²
Starting torque – at 20 °C [68 °F]	< 0.05 Nm
Shaft load capacity	radial 40 N axial 20 N
Weight	ca. 0.17 kg [6.00 oz]
Protection acc. to EN 60529	IP64
Working temperature range	-20 °C ... +70 °C [-4 °F ... +158 °F]
Materials	shaft stainless steel flange aluminum housing aluminum cable PVC
Shock resistance acc. to EN 60068-2-27	1000 m/s ² , 6 ms
Vibration resistance acc. to EN 60068-2-6	100 m/s ² , 55 ... 2000 Hz

Approvals	
UL compliant in accordance with	File no. E224618
CE compliant in accordance with	
EMC Directive	2014/30/EU
RoHS Directive	2011/65/EU

1) Max. recommended cable length 30 m [98.43'].
 2) If supply voltage correctly applied.
 3) Only one channel allowed to be shorted-out:
 at +V= 5 V DC, short-circuit to channel, 0 V, or +V is permitted.
 at +V= 5 ... 30 V DC, short-circuit to channel or 0 V is permitted.

Incremental encoders

Compact optical

Sendix Base KIS40 / KIH40 (shaft / hollow shaft)

Push-pull / RS422 / Open collector

Terminal assignment - Standard wiring

Output circuit	Type of connection	Cable (isolate unused cores individually before initial start-up)								
3, 4, 6, A, B, C with inv. signal	1, 2, A, B	Signal:	0 V	+V	A	\bar{A}	B	\bar{B}	0	$\bar{0}$
		Core color:	WH	BN	GN	YE	GY	PK	BU	RD

Output circuit	Type of connection	Cable (isolate unused cores individually before initial start-up)								
7, 8 without inv. signal	1, 2, A, B	Signal:	0 V	+V	A	–	B	–	0	–
		Core color:	WH	BN	GN	–	GY	–	BU	–

Output circuit	Type of connection	M12 connector, 8-pin									
3, 4, 6, A, B, C with inv. signal	6	Signal:	0 V	+V	A	\bar{A}	B	\bar{B}	0	$\bar{0}$	\perp
		Pin:	1	2	3	4	5	6	7	8	PH ¹⁾

Output circuit	Type of connection	M12 connector, 5-pin						
7, 8 without inv. signal	4	Signal:	0 V	+V	A	B	0	\perp
		Pin:	1	2	3	4	5	PH ¹⁾

Terminal assignment – Special connector pin configuration

Order code ❶	Output circuit	Type of connection	M12 connector, 8-pin									
7	4, 6	6	Signal:	0 V	+V	A	\bar{A}	B	\bar{B}	0	$\bar{0}$	\perp
			Pin:	7	2	1	3	4	5	6	8	PH ¹⁾

Order code ❶	Output circuit	Type of connection	M12 connector, 5-pin						
9	8	4	Signal:	0 V	+V	A	B	0	\perp
			Pin:	3	1	4	2	5	PH ¹⁾

Order code ❶	Output circuit	Type of connection	M12 connector, 8-pin									
A	4, 6	6	Signal:	0 V	+V	A	\bar{A}	B	\bar{B}	0	$\bar{0}$	\perp
			Pin:	7	8	2	1	4	3	6	5	PH ¹⁾

- +V: Supply voltage encoder +V DC
- 0 V: Supply voltage encoder ground GND (0 V)
- A, \bar{A} : Incremental output channel A
- B, \bar{B} : Incremental output channel B
- 0, $\bar{0}$: Reference signal

1) PH = shield is attached to connector housing.

Incremental encoders

Compact optical **Sendix Base KIS40 / KIH40 (shaft / hollow shaft)** **Push-pull / RS422 / Open collector**

Dimensions shaft version

Dimensions in mm [inch]

Clamping-synchro flange, ø 40 [1.57]

Flange type 1

- 1 3 x M3, 4 [0.16] deep
- 2 4 x M3, 4 [0.16] deep

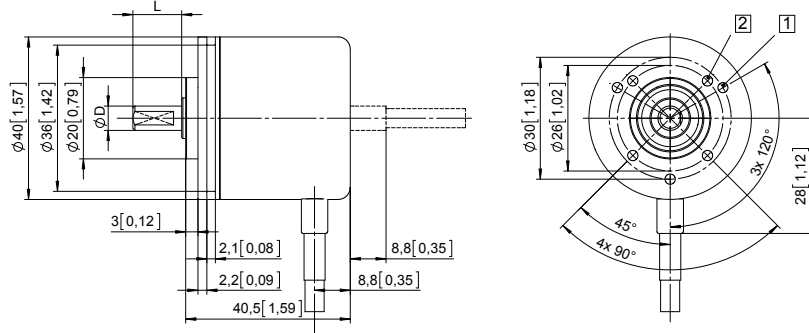

D	Fit	L
6 [0.24]	h7	12.5 [0.49]
1/4"	h7	12.5 [0.49]
8 [0.32]	h7	12.5 [0.49]

Dimensions hollow shaft version

Dimensions in mm [inch]

Flange with spring element, long

Flange type 2

- 1 M2,5, 4 [0.16] deep

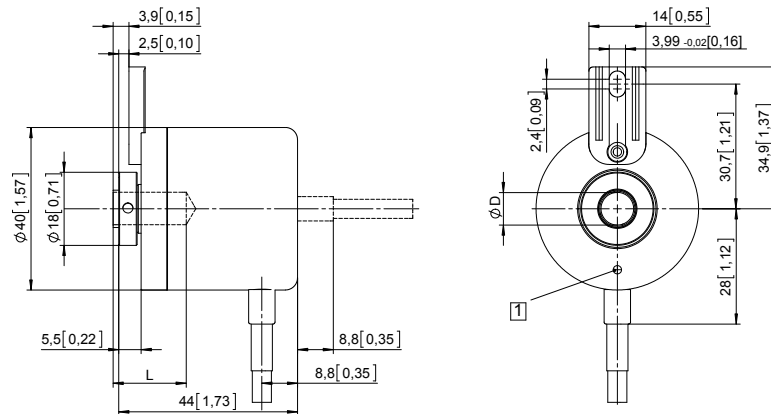

D	Fit	L
6 [0.24]	H7	18 [0.71]
8 [0.32]	H7	18 [0.71]
1/4"	H7	18 [0.71]

L = insertion depth max. blind hollow shaft
insertion depth min. = 15 mm [0.59]

Flange with stator coupling, ø 46 [1.81]

Flange type 5

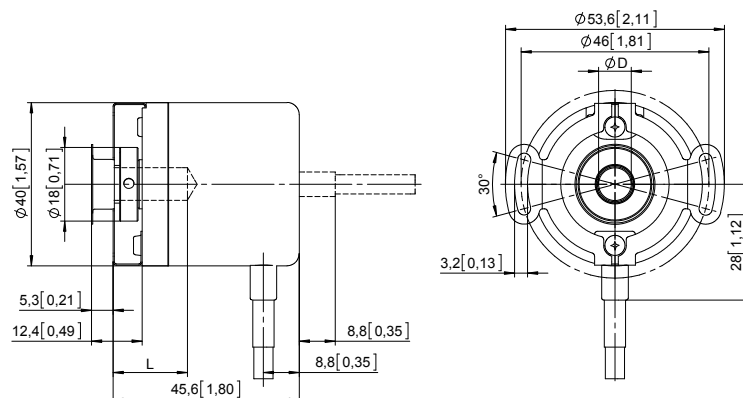

D	Fit	L
6 [0.24]	H7	18 [0.71]
8 [0.32]	H7	18 [0.71]
1/4"	H7	18 [0.71]

L = insertion depth max. blind hollow shaft
insertion depth min. = 15 mm [0.59]