

Inclinometers

**For static applications
1- and 2-axis, metal housing**

IN88 **Fieldbus**



The inclinometers of the IN88 series allow measuring 2-axis inclinations in the range of $\pm 85^\circ$ or 1-axis inclinations up to 360° . With their high robustness, their protection level up to max. IP69k and their wide temperature range from -40°C to $+85^\circ\text{C}$, these devices are ideally suitable for outdoor use – e.g. for mobile automation applications.



Features and benefits

- For different fieldbus systems**
 Variants for CANopen, SAEJ1939 or Modbus
- Individual settings via the fieldbus interface**
 - Define preset (zero point / midpoint position)
 - Setting the sensor filter
 - Resetting to factory settings
- Redundant measurement**
 The housing offers the option of mounting sensors in stacks in order to easily implement redundant measurement in the application.
- Simple start-up and diagnostics**
 - LED display for quick and visual detection of the operating status.
 - Optimum integration and loop-through in bus networks thanks to 2x M12 connector options
- Precise measurement even under harsh environmental conditions**
 - Temperature range -40°C ... $+85^\circ\text{C}$ and protection class IP67 / IP69k
 - Protection against the influence of salt spray and rapid temperature changes
 - E1-approval
- Maximum robustness**
 The robust metal housing also protects the electronics from extreme mechanical influences.

Order code

8	IN88	.	1	7	X	1	.	1	2	X
Type			a	b						e

1-axis

- a Measuring range**
 7 = $0 \dots 360^\circ (\pm 180^\circ)$
- b Interface**
 2 = CANopen
 3 = SAE J1939
 6 = Modbus RTU
- e Type of connection**
 1 = 1 x M12 connector, 5-pin
 3 = 2 x M12 connector, 5-pin

Order code

8	IN88	.	2	6	X	1	.	1	2	X
Type			a	b						e

2-axis

- a Measuring range**
 6 = $\pm 85^\circ$
- b Interface**
 2 = CANopen
 3 = SAE J1939
 6 = Modbus RTU
- e Type of connection**
 1 = 1 x M12 connector, 5-pin
 3 = 2 x M12 connector, 5-pin

Inclinometers

For static applications 1- and 2-axis, metal housing		IN88	Fieldbus
Accessories			Order no.
Adapter plate	for installation identical to Kübler inclinometer IS60		8.0010.4062.0000
Cables and connectors			Order no.
Preassembled cables	M12 female connector with coupling nut for Bus in, 5-pin, A coded, straight single ended 5 m [16.40'] PVC cable		05.00.6091.A211.005M
	M12 male connector with external thread for Bus out, 5-polig, A coded, straight single ended 5 m [16.40'] PVC cable		05.00.6091.A411.005M
	M12 female connector with coupling nut for Bus in, 5-polig, A coded, straight Deutsch connector, 6-pin, DT04 1 m [3.28'] PVC cable		05.00.6091.22C7.001M
Connectors	M12 female conn. with coupling nut for Bus in, 5-pin, A coded, straight (metal/plastic)		05.B-8151-0/9
	M12 male conn. with external thread for Bus out, 5-pin, A coded, straight (metal/plastic)		05.BS-8151-0/9

Further Kübler accessories can be found at: kuebler.com/accessories

Further Kübler cables and connectors can be found at: kuebler.com/connection-technology

Inclinometers

For static applications 1- and 2-axis, metal housing	IN88	Fieldbus
---	-------------	-----------------

Technical data

General data 1-axis measurement	
Measuring range	0 ... 360°
Resolution	0.01°
Repeat accuracy	±0.2°
Temperature coefficient	typ. ±0.006°/K
Accuracy (at 25°C)	±0.1 ... ±0.2° depending on the measuring range

The graph shows accuracy in degrees on the y-axis (ranging from ±0.1 to ±0.5) against the measuring range in degrees on the x-axis (ranging from -180 to +180). The accuracy is relatively stable, fluctuating between approximately ±0.1 and ±0.2 degrees across the range.

General data 2-axis measurement	
Measuring range	-85 ... +85°
Resolution	0.01°
Repeat accuracy	±0.2°
Temperature coefficient	typ. ±0.006°/K
Transverse sensitivity	typ. ±0.3°
Accuracy (at 25°C)	±0.2° ... ±0.4° depending on the measuring range

The graph shows accuracy in degrees on the y-axis (ranging from ±0.1 to ±0.5) against the measuring range in degrees on the x-axis (ranging from -85 to +85). The accuracy curve shows a slight increase in error towards the extremes of the range, peaking at approximately ±0.4 degrees.

General electrical characteristics	
Supply voltage	10 ... 30 V DC
Current consumption (no load)	max. 70 mA
Reverse polarity protection of the supply voltage	yes
Sampling rate	50 Hz (20 ms)
Limit frequency with Butterworth filter factory setting	0.1 ... 10 Hz, 8th order typ. 10 Hz

EMC		
Relevant standards	EN 61326-1	Electrical equipment for measurement, control and laboratory use
	EN 61000-6-2	Immunity for industrial environments
	EN 55011 Klasse B, EN 61000-6-3	Emitted interferences for residential environments
	EN ISO 14982	Agricultural and forestry machinery, electromagnetic compatibility, test methods and acceptance criteria
	EN 13309:2010-07	Construction machinery - Electromagnetic compatibility of machines with internal supply voltage

Mechanical characteristics		
Connection	1 x M12 connector 2 x M12 connector	5-pin, male connector 5-pin, male connector / 5-pin, female connector
Weight	approx. 185 g [6.53 oz]	
Protection acc. to EN 60529	IP67 / IP69k ¹⁾	
Working temperature range	-40 °C ... +85 °C [-40 °F ... +185 °F]	
Material	housing	aluminum
Shock resistance acc. to EN 60068-2-27	1000 m/s ² , 6 ms	
Vibration resistance acc. to EN 60068-2-6	100 m/s ² , 10 ... 2000 Hz	
Dimensions	80 x 60 x 23 mm [3.15 x 2.36 x 0.91"]	

Approvals		
E1 compliant in accordance with	ECE guideline	
UL compliant in accordance with ¹⁾	File no. E224618	
CE compliant in accordance with	EMC Directive	2014/30/EU
	RoHS Directive	2011/65/EU

1) The IP protection class is not UL-tested. Verified by Kübler.

Inclinometers

For static applications
1- and 2-axis, metal housing

IN88

Fieldbus

Dimensions

Dimensions in mm [inch]

1 x M12 connector 5-pin, male contacts

1 x M12 connector 5-pin, male contacts

1 x M12 connector 5-pin, female contacts

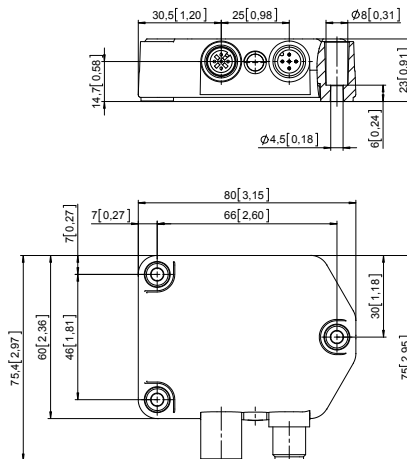
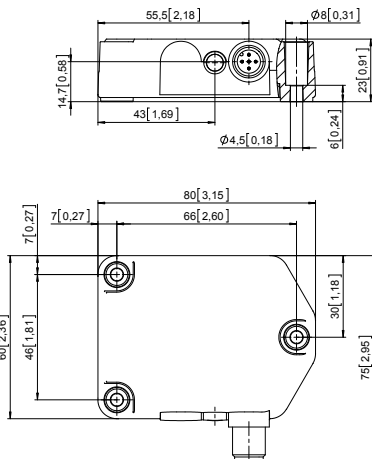

Adapter plate

for installation identical to Kübler inclinometer IS60

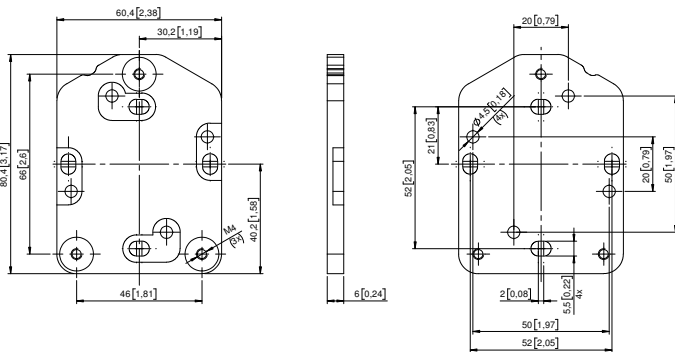

Inclinometers

For static applications 1- and 2-axis, metal housing	IN88	Fieldbus / CANopen
---	-------------	---------------------------

Interface characteristics CANopen

General information on CANopen

The CANopen inclinometers support the latest CANopen communications profile according to DS301. In addition, device-specific profiles such as the inclinometer profile DS410 and DS305 (LSS) are available.

The following operating modes may be selected: Polled Mode, Cyclic Mode, Sync Mode. Moreover, scale factors, preset values and many other additional parameters can be programmed via the CAN bus. When switching the appliance on, all parameters are loaded from a flash memory. These parameters have previously been stored in a zero-voltage secure manner. The output values **position, position raw value, sensor temperature and sensor information** can be combined very variably as a PDO (PDO mapping). The inclinometers are available with one or two connectors.

The device address and baud rate can be set/modified by means of the software.

The two-color LED indicates the operating or fault status of the CAN bus, as well as the status of the internal diagnostics.

LSS layer setting services DS305 V2.2

- Global command support for node address and baud rate configuration.
- Selective protocol via identity object (1018h).

CANopen communication profile DS301 V4.2

Among others, the following functionality is integrated (Class C2 functionality):

- NMT slave.
- Heartbeat protocol.
- Identity object.
- Error behavior object.
- Variable PDO mapping, 2 sending PDO's.
- Node address, baud rate and programmable CANbus termination.

Characteristics CANopen

Interface	CAN high-speed acc. to ISO 11898, Basic- and Full-CAN CAN specification 2.0 B
Protocol	CANopen profile DS410 V1.3 with manufacturer-specific add-ons, communication profile DS301 V4.2
Baud rate	10 kbit/s, 20 kbit/s, 50 kbit/s, 125 kbit/s, 250 kbit/s, 500 kbit/s, 800 kbit/s, 1 Mbit/s software configurable
Node address	1 ... 127 software configurable
Termination switchable	software configurable
LSS protocol	DS305 layer setting services 2.2

CANopen Inclinometer profile DS410 V1.3

The following parameters can be programmed:

- Variable PDO mapping of position, position raw value, sensor temperature and sensor information.
- Extended failure management.
- User interface with visual display of bus and failure status - 1 LED two-color.
- Customer-specific protocol.
- "Watchdog controlled" device.

Terminal assignment

Interface	Type of connection	1 x M12 connector, 5-pin						
		Bus IN						
		Signal:	+V	0 V	CAN_GND	CAN_H		CAN_L
2	1	Pin:	2	3	1	4	5	
Interface	Type of connection	2 x M12 connector, 5-pin						
		Bus OUT						
		Signal:	+V	0 V	CAN_GND	CAN_H		CAN_L
		Pin:	2	3	1	4		5
		Bus IN						
		Signal:	+V	0 V	CAN_GND	CAN_H		CAN_L
2	3	Pin:	2	3	1	4	5	

Inclinometers

**For static applications
1- and 2-axis, metal housing**

IN88

Fieldbus / CANopen

Interface characteristics CANopen

CANopen object dictionary

Index (hex)	Sub Index	Data type	Name	Default value
1005h	0	U32	COB-ID Sync	80h
1014h	0	U32	COB-ID Emcy	BEh
1017h	0	U32	Producer heartbeat time	0
	1	U8	Communication Error	0
	2	U8	Sync Error	0
	3	U8	Internal Device Error	0
1800h			TPDO1 Communication Parameter	
	1	U32	COB-ID	1BEh
	2	U8	Transmission Type	255
	5	U16	Event timer	0 [step 1 ms]
1801h			TPDO2 Communication Parameter	
	1	U32	COB-ID	2BEh
	2	U8	Transmission Type	1
	5	U16	Event timer	0 [step 1 ms]
Mapping at 2-dimensional				
1A00h			TPDO1 Mapping	
	0	U8	Number of Entries	3
	1	U32	1.Mapped Object	0x60100010
	2	U32	2.Mapped Object	0x60200010
	3	U32	3.Mapped Object	0x50000010
	4	U32	4.Mapped Object	0
1A01h			TPDO2 Mapping	
	0	U8	Number of Entries	3
	1	U32	1.Mapped Object	0x60100010
	2	U32	2.Mapped Object	0x60200010
	3	U32	3.Mapped Object	0x50000010
	4	U32	4.Mapped Object	0
Mapping at 1-dimensional				
1A00h			TPDO1 Mapping	
	0	U8	Number of Entries	2
	1	U32	1.Mapped Object	0x60100010
	2	U32	2.Mapped Object	0x50000010
	3	U32	3.Mapped Object	0
	4	U32	4.Mapped Object	0
1A01h			TPDO2 Mapping	
	0	U8	Number of Entries	2
	1	U32	1.Mapped Object	0x60100010
	2	U32	2.Mapped Object	0x50000010
	3	U32	3.Mapped Object	0
	4	U32	4.Mapped Object	0

Index (hex)	Sub Index	Data type	Name	Default value
Profile DS410 Inclinometer				
6000h	0	U16	Resolution	0
6011h	0	U8	Slope long16 operating parameter	0
6012h	0	I16	Slope long16 preset value	0
6013h	0	I16	Slope long16 offset	0
6014h	0	I16	Differential Slope long16 offset	0
6021h .. 6024h only at 2-dimensional				
6021h	0	U8	Slope lateral16 operating parameter	0
6022h	0	I16	Slope lateral16 preset value	0
6023h	0	I16	Slope lateral16 offset	0
6024h	0	I16	Differential Slope lateral16 offset	0
Manufacturer specific objects				
2100h	0	U8	Baudrate	5 (250 kBit/s)
2101h	0	U8	Node Number	0x3E (62d)
2102h	0	U8	Termination	1 = ON
2105h	0	U32	Save All Bus Parameters	0x65766173
3000h	0	U16	Digital Filter Active	1 = ON
3001h	0	F32	Digital Filter Coefficient	10.0

Uxx = UNSIGNED
 lxx = SIGNED
 Fxx = FLOAT
 Name = Name of the object

Inclinometers

For static applications 1- and 2-axis, metal housing	IN88	Fieldbus / SAEJ1939
---	-------------	----------------------------

Interface characteristics SAE J1939

General information concerning SAE J1939

The protocol J1939 originates from the international Society of Automotive Engineers (SAE) and operates on the physical layer with high speed CAN as per ISO11898. The application emphasis lies in the area of the power train and chassis of commercial vehicles. It serves to transfer diagnostic data (for example, motor speed, position, temperature) and control information. The inclinometers IN88 support the total functionality of J1939.

This protocol is a multimaster system with decentralized network management that does not involve channel-based communication.

It supports up to 254 logic nodes and 30 physical control devices per segment. The information is described as parameters (signals) and combined on 4 memory pages (data pages) into parameter groups (PGs). Each parameter group can be identified via a unique number, the parameter group number (PGN). Independently of this, each signal is assigned a unique SPN (suspect parameter number).

The major part of the communication occurs cyclically and can be received by all control devices without the explicit request for data (Broadcast). Furthermore the parameter groups are optimized to a length of 8 data bytes. This enables very efficient utilization of the CAN protocol. If greater amounts of data need to be transferred, then transport protocols (TP) can be used: BAM (broadcast announce message) and CDMT (connection mode data transfer). With BAM TP the transfer of data occurs as a broadcast.

- Inclinometer implementation SAE J1939**
- PGNs that are adaptable to the customer's application.
 - Resolution of address conflicts -> Address Claiming (ACL).
 - Continuous checking whether control addresses have been assigned twice within a network.
 - Change of control device addresses during run-time.
 - Unique identification of a control device with the help of a name that is unique worldwide. This name serves to identify the functionality of a control device in the network.
 - Predefined PGs for position, speed and alarm.
 - 250 kbit/s, 29 bit identifier.
 - Watchdog controlled device.
- A two-color LED signals the operating and fault status of the SAE J1939 protocol, as well as the status of the internal diagnostics.

Characteristics SAE J1939

Interface	CAN high-speed acc. to ISO 11898, CAN specification 2.0 B
Baud rate	250 kbit/s, switchable by software to 500 kbit/s
Node address	software configurable
Termination switchable	software configurable

Terminal assignment

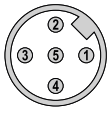
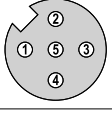
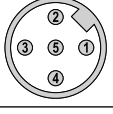
Interface 3	Type of connection 1	1 x M12 connector, 5-pin								
		Bus IN								
		Signal:	+V	0 V	CAN_GND	CAN_H		CAN_L		
		Pin:	2	3	1	4	5			
Interface 3	Type of connection 3	2 x M12 connector, 5-pin								
		Bus OUT								
		Signal:	+V	0 V	CAN_GND	CAN_H		CAN_L		
				Pin:	2	3	1	4	5	
		Bus IN								
		Signal:	+V	0 V	CAN_GND	CAN_H		CAN_L		
		Pin:	2	3	1	4	5			

Inclinometers

For static applications 1- and 2-axis, metal housing	IN88	Fieldbus / SAEJ1939
---	-------------	----------------------------

Interface characteristics SAE J1939

Configuration data signals PG				
Configuration data	Data length in byte	Hex value	Hex value in decimal	Endian hex value
INCLIN_CFG_Resolution	2	0x0064	100	0x6400
INCLIN_CFG_LongOperatingPar	1	0x02	2	0x02
INCLIN_CFG_SlopeLongPreset_Activate	1	0x01	1	0x01
INCLIN_CFG_SlopeLongPresetValue	2	0x0000	0	0x0000
INCLIN_CFG_LatOperatingPar	1	0x02	2	0x02
INCLIN_CFG_SlopeLatPreset_Activate	1	0x01	1	0x01
INCLIN_CFG_SlopeLatPresetValue	2	0x0000	0	0x0000
INCLIN_CFG_TxCycleTime	2	0x0032	50	0x3200
INCLIN_CFG_NodeID	1	0x20	32	0x20
INCLIN_CFG_BitRate	1	0x00	0	0x00
INCLIN_CFG_CAN_Termination	1	0x01	1	0x01
INCLIN_CFG_FilterConfig	1	0x06	6	0x06

Inclinometers

For static applications 1- and 2-axis, metal housing	IN88	Fieldbus / Modbus
---	-------------	--------------------------

Interface characteristics Modbus

General information on Modbus

Modbus communication profile V 1.02
Node number, baudrate and bus termination programmable.

Modbus application protocol V1.1b3

Characteristics Modbus	
Interface	Modbus V1.02
Protocol	Modbus RTU V1.1b3
Baud rate	4800 ... 115200 kbit/s, software configurable
Node address	1 ... 63, software configurable
Termination	software configurable

Read Holding Register – Function code 03 ¹⁾				
Reg.	Data name	ATT	Value	Default
00001	LOTWINKEL X-ACHSE	I16	Inclination angle in 0.01 °	-85.00 ... +85.00
00002	LOTWINKEL Y-ACHSE	I16	Rotation angle in 0.01 °	-85.00 ... +85.00
00003	EULERWINKEL X-ACHSE	I16	Euler angle (1 axis)	0 ... 180.99°
00004	EULERWINKEL Y-ACHSE	U16	Euler angle (1 axis)	0 ... 359.99°
00007	VERSORGUNG VCC	U16	VCC in 0.1 VDC	240
00008	TEMPERATURE IN 0.1°C	U16	Temp. in 0.1°	210
00016	SIDEVIEW	U16	Back = 0, Front = 1	0
00023	SYSTEM STATE	U16	No errors = 0	0
00140	BAUDRATE	U16	Current baudrate	19200 Baud (2)
00144	NODE-ID	U16	Current node address	63
00145	TERMINIERUNG	U16	Termination on/off	2 (on)
00146	FILTER AKTIVIERUNG	U16	Filter on/off	1 (on)
00147	FILTER EINSTELLUNG	F32	Filter value in HZ	5.0
00148	SERIENNUMMER	U32	Serial number	YYDDNNNNN
00149	PRODUCT CODE	U32	Device type	x88616100
00150	AUFLÖSUNG	U16	Resolution X/Y axis	0.01° (10)
00151	OPERATING PARAMETER	U16	Setting X axis	0
00152	PRESET X-ACHSE	U16	Preset X axis	0
00153	OFFSET X-ACHSE	U16	Offset X axis	0
00154	DIFF.OFFSET X-ACHSE	U16	Differential offset	0
00155	Operating Parameter	U16	Setting Y axis	0
00156	PRESET Y-ACHSE	U16	Preset Y axis	0
00157	OFFSET Y-ACHSE	U16	Offset Y axis	0
00158	DIFF.OFFSET Y-ACHSE	U16	Differential offset	0
00159	OFFSET EULERWINKEL	U16	Offset Euler axis Y	0

Write Holding Register – Function code 16 (0x10)					
Reg.	Value	R/W	Format	Content	Default
300	VAR	W	U16	Baudrate	19200 Baud (2)
301	VAR	W	U16	Parity	1 = none
302	VAR	W	U16	Stoppbit	1 = 1 Stoppbit
304	VAR	W	U16	Node Number	0x3E (62d)
305	VAR	W	U16	Termination	2 = ON
306	VAR	W	U16	Digital Filter Active	1 = ON
307	VAR	W	F32	Digital Filter Coefficient	5.0
310	VAR	W	U16	Resolution of axis	10
311	VAR	W	U16	Slope long16 operating parameter	0
312	VAR	W	I16	Slope long16 preset value	0
313	VAR	W	I16	Slope long16 offset	0
314	VAR	W	I16	Differential Slope long16 offset	0
315	VAR	W	U16	Slope lateral16 operating parameter	0
316	VAR	W	I16	Slope lateral16 preset value	0
317	VAR	W	I16	Slope lateral16 offset	0
318	VAR	W	I16	Differential Slope lateral16 offset	0
320	VAR	W	U16	Preset Euleraxis (only 0)	0
261	VAR	W	U16	Delaytime for Transmission	1
360	VAR	W	U16	Save All Application Parameters	0x1010
361	VAR	W	U16	Load All Parameters (Factory default)	0x10101

Terminal assignment

Interface	Type of connection	1 x M12 connector, 5-pin						
6	1	Bus IN						
		Signal:	+V	0 V	D0	D1		TG
		Pin:	2	3	5	4		1
6	3	Bus OUT						
		Signal:	+V	0 V	D0	D1		TG
		Pin:	2	3	5	4		1
		Bus IN						
		Signal:	+V	0 V	D0	D1		TG
		Pin:	2	3	5	4		1

1) Reads the binary contents of holding registers (4XXX references) in the encoder slave. Broadcast is not supported.

Inclinometers

For static applications
1- and 2-axis, metal housing

IN88

Fieldbus

Technology in detail

Exact angular position via acceleration measurement

Acceleration measurement

In the acceleration measuring cell, the absolute angular position is determined capacitively in relation to the gravity acceleration \vec{g} .

The displacement **2** of a test mass **1** changes the distance and therefore also the capacity **F** between fixed **3** and moving **4** electrodes in the measuring cell. This measured capacity is directly related to the inclination of the sensor.

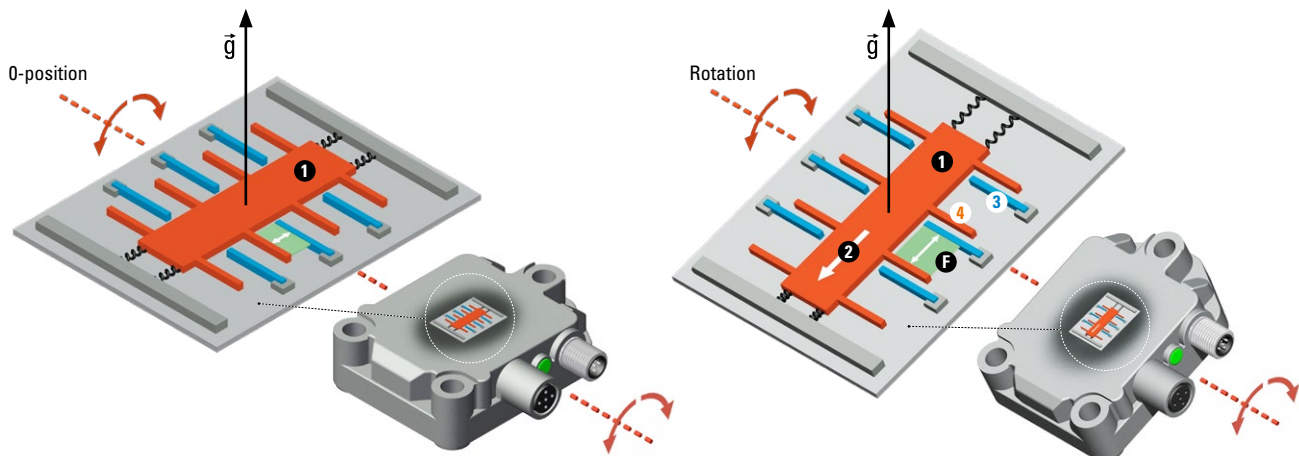

Optimization of the measurement using filter functions

The inertia of the test mass, particularly in the case of fast or rapidly changing rotations and vibrations, can lead to inaccuracies in the detected measurement data **b** compared to the actual movement **a**. To compensate for these undesirable effects, various filters **c** + **d** can be parameterized in the inclinometer.

Restrictions due to filters

However, this leads to a time delay ($\Delta t_c + \Delta t_d$) for the output of the measurement result (the more precise the desired measurement, the greater the time delay).

Further optimization with dynamic inclinometers

This time delay is not relevant for many static applications (such as solar panels, crane masts, etc.). In dynamic applications (e.g. vehicles in motion), however, this can lead to problems, as a reaction to the movement can only occur with a delay. In this case, it is advisable to use a dynamic inclinometer IN71 with intelligent sensor fusion from Kübler for further optimization of the measurement result.

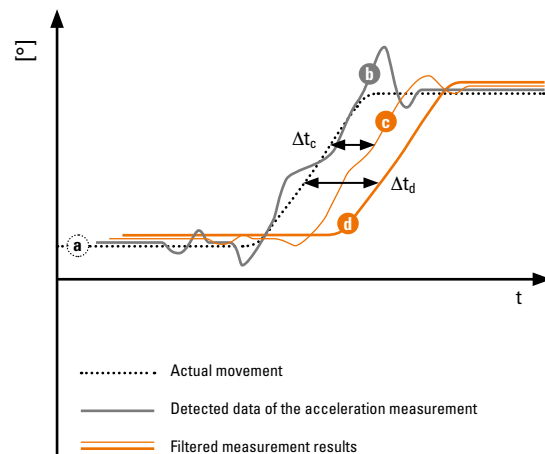

Inclinometers

For static applications 1- and 2-axis, metal housing	IN88	Fieldbus
---	-------------	-----------------

Technology in detail

Simple redundancy thanks to stackability

Using the same fastening devices on the application, 2 inclinometers type IN88 can be mounted stacked.

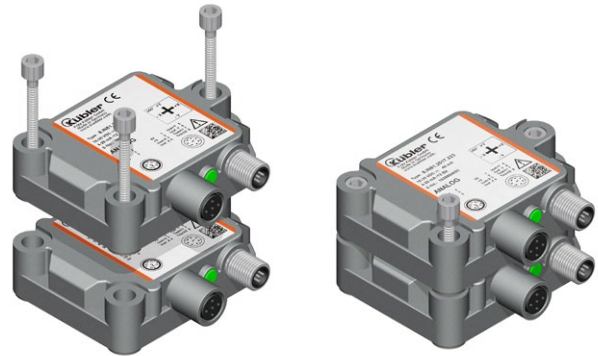

Flexible use in different network topologies

1- or 2-connector technology for bus-in/bus-out

