

Linear measuring technology

Draw-wire encoder C100	Base-Line	Measuring length max. 5 m
-------------------------------	------------------	----------------------------------



The draw wire system C100 is more than a sensor for determining length-related position data. Variants with integrated inclinometer and redundant interfaces offer versatile application possibilities. The contactless magnetic position scanning, a high IP67 protection level and the wider temperature range round off the product.



Analog output



Wide temperature range	High protection level	Shock / vibration resistant	Redundancy	Relay output	Switching outputs

Characteristics

- Measuring length up to 5 m.
- Integrated inclinometer.
- Redundant sensors.
- Different types of sensors (analog, incremental, CANopen, relay output, switch output).
- Linearity up to $\pm 0.1\%$ of the measuring range.
- High protection level IP67 and wide temperature range from -40 °C ... $+85\text{ °C}$.

Advantages

- The suitable measuring length for every application.
- Cost, space and installation work saving.
- For even higher plant availability.
- Simple selection and fast installation.
- High accuracy at economic prices.
- Reliability and long service life for outdoor applications.

Order code with analog sensor

D8 . C100 . XXXX . XXX 1 . 1 000

- | | | |
|---------------------------|-------------------------|-----------------------------|
| a Measuring length | b Single sensor | c Type of connection |
| 0100 = 1 m | A11 = 4 ... 20 mA | 1 = M12 connector, 5-pin |
| 0200 = 2 m | A22 = 0 ... 10 V | |
| 0300 = 3 m | A44 = 0.5 ... 4.5 V | d Supply voltage |
| 0400 = 4 m | | 1 = 12 ... 30 V DC |
| 0500 = 5 m | <i>Redundant sensor</i> | |
| | R11 = 2 x 4 ... 20 mA | |
| | R22 = 2 x 0 ... 10 V | |
| | R44 = 2 x 0.5 ... 4.5 V | |

Order code with CANopen and inclinometer

D8 . C100 . XXXX . XXX 1 . 1 X 00

- | | | | |
|---------------------------|---|-----------------------------|------------------------|
| a Measuring length | b Sensor type | c Type of connection | e Inclinometers |
| 0100 = 1 m | RC1 = CANopen redundant | 1 = M12 connector, 5-pin | 0 = none |
| 0200 = 2 m | RCT = CANopen redundant, with termination resistor 120 Ω | | 1 = 1 inclinometer |
| 0300 = 3 m | | d Supply voltage | 2 = 2 inclinometers |
| 0400 = 4 m | | 1 = 9 ... 30 V DC | |
| 0500 = 5 m | | | |

Stock types
D8.C100.0500.RC11.1000

Linear measuring technology

Draw-wire encoder C100	Base-Line	Measuring length max. 5 m
-------------------------------	------------------	----------------------------------

Order code with incremental output	<table border="1" style="width:100%; border-collapse: collapse;"> <tr> <td style="width: 15%; text-align: center;">D8.</td> <td style="width: 15%; text-align: center;">C100</td> <td style="width: 15%; text-align: center;">.XXXX</td> <td style="width: 15%; text-align: center;">.XXX</td> <td style="width: 15%; text-align: center;">X</td> <td style="width: 15%; text-align: center;">.1</td> <td style="width: 15%; text-align: center;">000</td> </tr> <tr> <td></td> <td></td> <td style="text-align: center;">a</td> <td style="text-align: center;">b</td> <td style="text-align: center;">c</td> <td style="text-align: center;">d</td> <td></td> </tr> </table>	D8.	C100	.XXXX	.XXX	X	.1	000			a	b	c	d	
D8.	C100	.XXXX	.XXX	X	.1	000									
		a	b	c	d										
a Measuring length 0100 = 1 m 0200 = 2 m 0300 = 3 m 0400 = 4 m 0500 = 5 m	b Sensor type I11 = incremental AB, 512 ppr I12 = incremental ABZ, 512 ppr I21 = incremental AB, 1024 ppr I22 = incremental ABZ, 1024 ppr	c Type of connection 1 = M12 connector, 5-pin 3 = radial cable, 2 m [6.56'] d Output circuit / Supply voltage 1 = TTL / 9 ... 30 V DC													

Order code with relais output	<table border="1" style="width:100%; border-collapse: collapse;"> <tr> <td style="width: 15%; text-align: center;">D8.</td> <td style="width: 15%; text-align: center;">C100</td> <td style="width: 15%; text-align: center;">.XXXX</td> <td style="width: 15%; text-align: center;">.RL1</td> <td style="width: 15%; text-align: center;">1</td> <td style="width: 15%; text-align: center;">.1</td> <td style="width: 15%; text-align: center;">000</td> </tr> <tr> <td></td> <td></td> <td style="text-align: center;">a</td> <td style="text-align: center;">b</td> <td style="text-align: center;">c</td> <td style="text-align: center;">d</td> <td></td> </tr> </table>	D8.	C100	.XXXX	.RL1	1	.1	000			a	b	c	d	
D8.	C100	.XXXX	.RL1	1	.1	000									
		a	b	c	d										
a Measuring length 0100 = 1 m 0200 = 2 m 0300 = 3 m 0400 = 4 m 0500 = 5 m	b Sensor type RL1 = relay output	c Type of connection 1 = M12 connector, 5-pin d Supply voltage 1 = 9 ... 30 V DC													

Order code with switch output	<table border="1" style="width:100%; border-collapse: collapse;"> <tr> <td style="width: 15%; text-align: center;">D8.</td> <td style="width: 15%; text-align: center;">C100</td> <td style="width: 15%; text-align: center;">.XXXX</td> <td style="width: 15%; text-align: center;">.SW3</td> <td style="width: 15%; text-align: center;">4</td> <td style="width: 15%; text-align: center;">.1</td> <td style="width: 15%; text-align: center;">000</td> </tr> <tr> <td></td> <td></td> <td style="text-align: center;">a</td> <td style="text-align: center;">b</td> <td style="text-align: center;">c</td> <td style="text-align: center;">d</td> <td></td> </tr> </table>	D8.	C100	.XXXX	.SW3	4	.1	000			a	b	c	d	
D8.	C100	.XXXX	.SW3	4	.1	000									
		a	b	c	d										
a Measuring length 0100 = 1 m 0200 = 2 m 0300 = 3 m 0400 = 4 m 0500 = 5 m	b Sensor type SW3 = 3 switch outputs	c Type of connection 4 = M12 connector, 12-pin d Supply voltage 1 = 9 ... 30 V DC													

Accessories relais output	Order no.
Teach adapter (for sensor type RL1) M12 connector, 5-pin adapter with button	D8.C100.RL1.TEACH
Accessories switch output	Order no.
Visualization adapter (for sensor type SW3) M12 connector, 12-pin	D8.C100.SW3.VISUAL
Connection technology	Order no.
Cordset, pre-assembled M12 female connector with coupling nut, 5-pin, A coded, straight single ended 2 m [6.56'] PVC cable	05.00.6081.2211.002M
M12 female connector with coupling nut, 12-pin, A coded, straight single ended 2 m [6.56'] PVC cable	05.00.60B1.B211.002M
Connector, self-assembly M12 female connector with coupling nut, 5-pin, A coded, straight (metal/plastic)	05.B-8151-0/9
M12 female connector with coupling nut, 5-pin, A coded, right-angle (plastic)	05.B-8251-0/9
M12 female connector with coupling nut, 12-pin, A coded, straight (metal)	8.0000.5162.0000

Further Kübler cables and connectors can be found at: kuebler.com/connection-technology

Linear measuring technology

Draw-wire encoder C100	Base-Line	Measuring length max. 5 m
-------------------------------	------------------	----------------------------------

Technical data

Mechanical characteristics (draw-wire mechanics)	
Measuring range	1.0 ... 5.0 m
Measuring wire	material AISI304 steel wire Nylon coated diameter \varnothing 0.9 mm \varnothing 0.61 mm (ABZ Incremental)
Wire fastening	eyelet internal diameter \varnothing 8 mm outer diameter \varnothing 15 mm height 2 mm
Speed max.	1 m/s
Acceleration max.	10 m/s ²
Linearity (whole measuring range)	analog \pm 0.8 % incremental (\leq 2 m) \pm 0.1 % incremental ($>$ 2 m) \pm 0.3 % CANopen / relay \pm 0.5 %
Repetition accuracy (whole measuring range)	analog \pm 0.3 % incremental (\leq 2 m) \pm 0.1 % incremental ($>$ 2 m) \pm 0.3 % CANopen / relay \pm 0.3 %
Pull-back force	typ. 2 N ¹⁾
Pull-out force	typ. 8 N
Drum circumference	245 mm
Type of connection	M12 connector, 5-pin cable, 2 m [6.56'] (only incremental)
Housing	polycarbonate reinforced with glass fibers
Protection	IP67
Temperature range	-40 °C ... +85 °C [-40 °F ... +185 °F]
Weight	approx. 0.5 kg [17.67 oz]
Shock resistance acc. to EN 60068-2-27	300 m/s ² , 11 ms
Vibration resistance acc. to EN 60068-2-6	100 m/s ² , 10 ... 500 Hz

Operating principle

Construction

The core of a draw-wire device is a drum mounted on bearings, onto which a wire is wound. Winding takes place via a spring-loaded device.

Note

Exceeding the maximum extension length of the draw-wire will lead to damage to the wire and the mechanics.

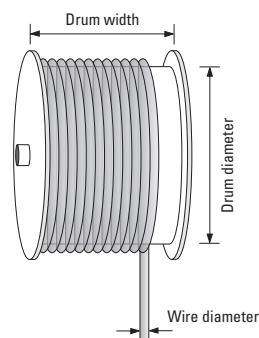

Electrical characteristics	
Supply voltage	
Sensor type:	
RC1, RCT, RL1, SW3, I11, I12, I21, I22	9 ... 30 V DC
A11, A22, A44, R11, R22, R44	12 ... 30 V DC
Electromagnetic compatibility	acc. to EN 61326-1, EN 61326-3-1
CE compliant	EMC guideline 2014/30/EU RoHS guideline 2011/65/EU

Analog sensor	
Output signal	analog
Resolution	12 bit

Incremental output	
Output signal	AB (Z optional)
Resolution	512 / 1024 ppr
Current consumption (non load)	max. 100 mA
Output current	max. 50 mA
Circuit	TTL

CANopen	
Output signal	CANopen (DS301)
Resolution	14 bit
Resolution inclinometer	0.1°
Accuracy inclinometer	\pm 0.6°
Temperature drift inclinometer	\pm 0.01 % / °C

Relay output	
Output signal	1x relay (Normally Open)
Maximum current	50 mA
Hysteresis	20 mm (factory setting)

Switch output	
Output signal	switch
Maximum current	0.5 A
Mechanical service life	
without load	min. 1,000,000 switching operations (60 switching operations/ min.)
under load	min. 30,000 switching operations (30 switching operations/ min.)

1) May be lower at low temperatures.

Linear measuring technology

Draw-wire encoder C100 Base-Line Measuring length max. 5 m

Terminal assignment

Sensor type	Interface	Type of connection	M12 connector, 5-pin					
Analog sensor A11, R11	(2x) 4 ... 20 mA	1	Signal:	+V	0 V	I _{out 1}	I _{out 2} ¹⁾	n.c.
			Pin:	1	2	3	4	5

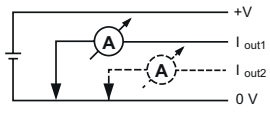

Sensor type	Interface	Type of connection	M12 connector, 5-pin					
Analog sensor A22, R22 A44, R44	(2x) 0 ... 10 V (2x) 0.5 ... 4.5 V	1	Signal:	+V	0 V	U _{out 1}	U _{out 2} ¹⁾	n.c.
			Pin:	1	2	3	4	5

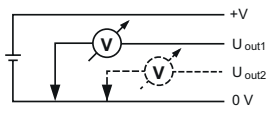

Sensor type	Interface	Type of connection	M12 connector, 5-pin					
I11, I12, I21, I22	incremental output	1	Signal:	+V	0 V	A	B	0
			Pin:	1	2	3	4	5

Sensor type	Interface	Type of connection	M12 connector, 5-pin					
RC1, RCT	CANopen	1	Signal:	+V	0 V	CAN-GND	CAN-H	CAN-L
			Pin:	2	3	1	4	5

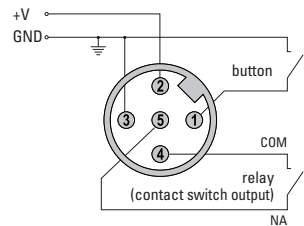
Sensor type	Interface	Type of connection	M12 connector, 5-pin					
RL1	relay	1	Signal:	+V	0 V	Teach	CAN-H	NO
			Pin:	2	3	1	4	5
			<p>The switching point of the relay can be set by means of a button connected to pin 1 (Teach). To do so, position the draw-wire mechanic at the desired switching point and then press the button once.</p> 					

Sensor type	Interface	Type of connection	Cable (isolate unused cores individually before initial start-up)					
I11, I12, I21, I22	incremental output	3	Signal:	+V	0 V	A	B	0
			Core color:	WH	YE	BN	GN	GY

Sensor type	Interface	Type of connection	M12 connector, 12-pin												
SW3	switching output	4	Signal:	NC 1	NO 1	C 1	NC 2	NO 2	C 2	NC 3	NO 3	C 3	n.c.	n.c.	n.c.
			Pin:	1	2	3	4	5	6	7	8	9	10	11	12

- +V : Supply voltage +V DC
- 0 V : Supply voltage GND (0V)
- I_{out 1} : Current output 1
- I_{out 2} : Current output 2
- U_{out 1} : Voltage output 1
- U_{out 2} : Voltage output 2
- A : Incremental output channel A
- B : Incremental output channel B
- 0 : Reference signal

- Teach : Teach function input
- C : Relay contact C
- NO : Relay contact N.O.
- n.c. : not connected
- AGND : Analog Ground

- C 1 : Switching contact C.1
- C 2 : Switching contact C.2
- C 3 : Switching contact C.3
- NO 1 : Switching contact N.O.1
- NO 2 : Switching contact N.O.2
- NO 3 : Switching contact N.O.3
- NC 1 : Switching contact N.C.1
- NC 2 : Switching contact N.C.2
- NC 3 : Switching contact N.C.3

Top view of mating side, male contact base

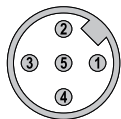

M12 connector, 5-pin

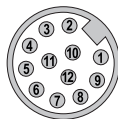

M12 connector, 12-pin

1) Only in case of redundant ordering option sensor type R11, R22, R44 (otherwise n.c.).

Linear measuring technology

Draw-wire encoder C100	Base-Line	Measuring length max. 5 m
-------------------------------	------------------	----------------------------------

Technology in detail

Inclinometer with option RC1
Setting possibility 360°

0°
0° ... 360°

Setting possibility ±180°

0°
±180°

Redundant signals possible.

Setting possibilities:

- Switching between setting possibilities 180° and 360°.
- Switching between synchronous and asynchronous output.
- Change of direction of rotation (cw/ccw).
- Setting and resetting an offset.

Dimensions

Dimensions in mm [inch]

