

Linear measuring technology

Draw-wire encoder A50	Performance-Line	Measuring length max. 1.25 m
------------------------------	-------------------------	-------------------------------------



The draw-wire mechanics A50 boast both a compact design and high dynamics.

The draw-wire mechanics may be equipped with encoders with an analog, incremental or absolute output. The maximum measuring length is 1.25 m.

Analog output **SAE J1939**

Max. acceleration 300 m/s ²	Long service life	Wide temperature range	High protection level IP	Reverse polarity protection	Integrated swivel

Robust

- The titanium-anodized aluminum housing and the stainless steel wires allow for using the mechanics even in harsh conditions.
- Wear-free wire exit thanks to special plain bearing guide.
- Various wire types and wire fastenings.

Versatile

- High traverse speed, up to 10 m/s.
- High acceleration, up to 300 m/s².
- Quick fastening by means of 2 screws.
- Various connection possibilities available.
- Scalable analog output with limit switch function.

Order code with encoder (incremental, absolute)

D8.6A1 . XXXX . XXXX . XXXX
Type a b c d e

- a** *Measuring range*
- 0025 = 250 mm
 - 0050 = 500 mm
 - 0100 = 1000 mm
 - 0125 = 1250 mm

- b** *Encoder used*
- 36 = Sendix 3610, incremental
 - M3 = Sendix M3663, absolute, SSI
 - F3 = Sendix F3663, absolute, SSI
 - M8 = Sendix M3668, absolute, CANopen
 - Sendix M3668, absolute, SAE J1939
 - Sendix M3668, absolute, IO-Link
 - F8 = Sendix F3668, absolute, CANopen

- c** *Output circuit*
depends on the encoder used
- d** *Type of connection*
depends on the encoder used
- e** *Resolution / Protocol / Options*
depends on the encoder used

- Optional on request*
- Other measuring ranges
 - Other wire fastening: M4 thread, eyelet or carabiner ring
 - Modified cable and/or connector orientation
 - Modified cable outlet direction
 - Sensor protection level IP67
 - Improved linearity (0.02 %)

Standard resolutions for draw-wire with incremental encoder Sendix 3610			
Drum circumference [mm]	125	125	125
Pulses / revolution [ppr]	125	1250	2500
Pulses / mm	1	10	20
Resolution [mm]	1	0.1	0.05

Standard resolutions for draw-wire with absolute encoder Sendix F3663/M3663 (12 bit ST) or F3668/M3668 (12 bit ST, programmable via bus)	
Drum circumference [mm]	125
Pulses / revolution [ppr]	4096
Pulses / mm	32.8
Resolution [mm]	0.03

Linear measuring technology

Draw-wire encoder A50 **Performance-Line** **Measuring length max. 1.25 m**

Recommended standard variants (with incremental, absolute encoder)

Order no. draw-wire encoder	Mounted encoder	Interface	Power supply	Type of connection	Resolution / Protocol	Option
D8.6A1.xxxx.3642.1250	3610 (8.3610.4342.1250)	Push-pull with inverted signal	8 ... 30 V DC	radial cable, 2 m	1250 ppr	-
D8.6A1.xxxx.M324.G222	Sendix M3663 (8.M3663.4124.G222)	SSI	10 ... 30 V DC	radial M12 connector	4096 ppr / SSI-Gray-Code	-
D8.6A1.xxxx.M824.2122	Sendix M3668 (8.M3668.4124.2122)	CANopen	10 ... 30 V DC	radial M12 connector	CANopen encoder profile DS406 V4.0	-
D8.6A1.xxxx.M834.3222	Sendix M3668 (8.M3668.4134.3222)	SAE J1939	10 ... 30 V DC	radial M12 connector	SAE J1939	-
D8.6A1.xxxx.M844.4122	Sendix M3668 (8.M3668.4144.4122)	IO-Link	18 ... 30 V DC	radial M12 connector	IO-Link	-

Other variants (with absolute encoder)

Order no. draw-wire encoder	Mounted encoder	Interface	Power supply	Type of connection	Resolution / Protocol	Option
D8.6A1.xxxx.F321.G222	Sendix F3663 (8.F3663.4121.G222)	SSI	10 ... 30 V DC	tangential cable, 1 m	4096 ppr / SSI-Gray-Code	-
D8.6A1.xxxx.F821.2122	Sendix F3668 (8.F3668.4121.2122)	CANopen	10 ... 30 V DC	tangential cable, 1 m	CANopen encoder profile DS406 V3.2	-

Order code with encoder (analog, scalable with limit switch function)

D8.6A1 . XXXX . M1XX . XXXX
 Type a b c d e

- a** *Measuring range*
 0025 = 250 mm
 0050 = 500 mm
 0100 = 1000 mm
 0125 = 1250 mm
 - b** *Encoder used*
 M1 = Sendix M3661, absolute ¹⁾
 - c** *Output circuit*
 depends on the encoder used
 - d** *Type of connection*
 depends on the encoder used
 - e** *Resolution / Protocol / Options*
 depends on the encoder used
- Optional on request*
- Other measuring ranges
 - Other wire fastening: M4 thread, eyelet or carabiner ring
 - Modified cable and/or connector orientation
 - Modified cable outlet direction
 - Sensor protection level IP67
 - Improved linearity (0.02 %)

Recommended standard variants (with analog encoder, scalable with limit switch function)

Order no. draw-wire encoder	Mounted encoder	Interface	Power supply	Type of connection	Resolution / Protocol	Option
D8.6A1.xxxx.M134.3612	Sendix M3661 (8.M3661.4134.3612)	Analog, 4 ... 20 mA	10 ... 30 V DC	M12-Stecker radial	12 Bit / 4 ... 20 mA	scalable without limit switch function ²⁾
D8.6A1.xxxx.M144.4612	Sendix M3661 (8.M3661.4144.4612)	Analog, 0 ... 10 V	15 ... 30 V DC	M12-Stecker radial	12 Bit / 0 ... 10 V	scalable without limit switch function ²⁾
D8.6A1.xxxx.M134.3512	Sendix M3661 (8.M3661.4134.3512)	Analog, 4 ... 20 mA	10 ... 30 V DC	M12-Stecker radial	12 Bit / 4 ... 20 mA	scalable with limit switch function ³⁾
D8.6A1.xxxx.M144.4512	Sendix M3661 (8.M3661.4144.4512)	Analog, 0 ... 10 V	15 ... 30 V DC	M12-Stecker radial	12 Bit / 0 ... 10 V	scalable with limit switch function ³⁾

Order code with analog sensor (scaled to measuring range)

D8.3A1 . XXXX . XXXX . 0000
 Type a b c 0000

- a** *Measuring range*
 0025 = 250 mm
 0050 = 500 mm
 0100 = 1000 mm
 0125 = 1250 mm
 - b** *Analog sensor output / supply voltage*
 A11 = 4 ... 20 mA / 12 ... 30 V DC
 A22 = 0 ... 10 V / 12 ... 30 V DC
 A33 = potentiometer 1 kΩ / max. 30 V DC
 - c** *Type of connection*
 1 = axial cable, 2 m PVC
 3 = axial M12 connector, 4-pin
- Optional on request*
- Other measuring ranges
 - Other wire fastening: M4 thread, eyelet or carabiner ring
 - Modified cable and/or connector orientation
 - Modified cable outlet direction
 - Sensor protection level IP67
 - Increased temperature range -40 °C ... +85 °C and -20 °C ... +120 °C

1) With ccw option.
 2) Delivery condition: scaled to measuring range. Description for scaling and limit switch function see data sheet M3661.
 3) Delivery condition: unscaled. Description for scaling and limit switch function see data sheet M3661.

Linear measuring technology

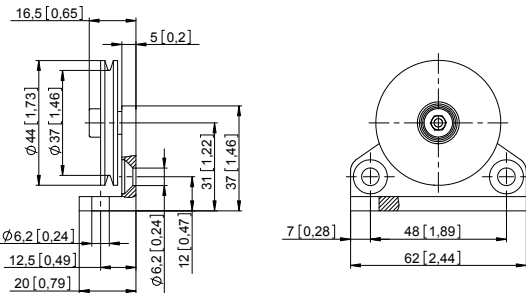
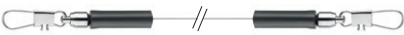
Draw-wire encoder A50	Performance-Line	Measuring length max. 1.25 m
Accessories for draw-wire encoder	Dimensions in mm [inch]	Order no.
Guide pulley 	Technical data: - mounting bracket (anodized alum.) - guide pulley (plastic POM) - ball bearing (type 696-2R5)	Scope of delivery: - 2 x countersunk screws for lateral fixing - 2 x hexagonal screws for fixing on a flat surface
		8.0000.7000.0045
Extension cable (further on request) 	0.5 m with clip 1.0 m with clip 2.0 m with clip	8.0000.7000.0051 8.0000.7000.0052 8.0000.7000.0054
Connection technology		Order no.
Cordset, pre-assembled	M12 female connector with coupling nut, 5-pin, A coded, straight single ended 2 m [6.56'] PVC cable	05.00.6081.2211.002M
Connector, self-assembly	M12 female connector with coupling nut, 5-pin, A coded, straight (metal) M12 female connector with coupling nut, 5-pin, A coded, straight (metal/plastic) M12 female connector with coupling nut, 5-pin, A coded, right-angle (plastic)	8.0000.5116.0000 05.B-8151-0/9 05.B-8251-0/9

Further Kübler connection technology can be found at: kuebler.com/connection-technology

Linear measuring technology

Draw-wire encoder A50	Performance-Line	Measuring length max. 1.25 m
------------------------------	-------------------------	-------------------------------------

Technical data

Mechanical characteristics (draw-wire mechanics)				
Measuring range		250 mm	500 mm	1250 mm
Extension force	F_{min}	6.8 N	3.4 N	4.1 N
	F_{max}	7.9 N	4.0 N	5.4 N
Speed max.		8 m/s	8 m/s	10 m/s
Acceleration max.		200 m/s ²	200 m/s ²	300 m/s ²
Linearity (of the measuring range)	with analog sensor	±0.15 %	±0.1 %	±0.1 %
	with encoder	±0.05 %	±0.05 %	±0.05 %
		±0.02 % ¹⁾	±0.02 % ¹⁾	±0.02 % ¹⁾
Weight		approx. 330 g [11.64 oz] (depending on the sensor / encoder used)		
Material	housing	titanium-anodized aluminum		
	wire	stainless steel ø 0.5 mm (other wire types on request)		
Protection acc. to EN 60529		IP65 (sensor)		

Electrical characteristics (digital output)
The electrical characteristics of the draw-wire mechanics with digital output can be found in the data sheets of the encoders.

Operating principle

Construction

The core of a draw-wire device is a drum mounted on bearings, onto which a wire is wound. Winding takes place via a spring-loaded device.

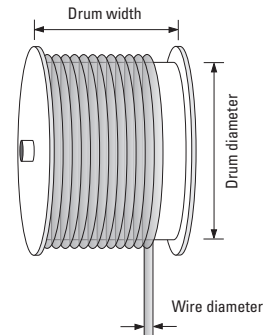

Note

Exceeding the maximum extension length of the draw-wire will lead to damage to the wire and the mechanics.

Electrical characteristics (analog sensor, scaled to measuring range)

Version	A22	A11	A33
Analog output	0 ... 10 V	4 ... 20 mA	potentiometer
Output	0 ... 10 V / galv. isolated, 4 conductors	4 ... 20 mA / 2 conductors	1 kΩ
Supply voltage	12 ... 30 V DC	12 ... 30 V DC	max. 30 V DC
Recommended slider current	–	–	< 1 μA
Max. current consumption	22.5 mA (no load)	50 mA	–
Reverse polarity protection	yes	yes	–
Working temperature	-20 °C ... +85 °C [-4 °F ... +185 °F]	-20 °C ... +85 °C [-4 °F ... +185 °F]	-20 °C ... +85 °C [-4 °F ... +185 °F]
	-40 °C ... +85 °C [-40 °F ... +185 °F] ²⁾	-40 °C ... +85 °C [-40 °F ... +185 °F] ²⁾	-40 °C ... +85 °C [-40 °F ... +185 °F] ²⁾
			-20 °C ... +120 °C [-4 °F ... +248 °F] ²⁾
CE compliant acc. to	EMC guideline 2014/30/EU RoHS guideline 2011/65/EU		

1) On request for encoder version: 36 (see order code **b**).

2) Optional on request.

Linear measuring technology

Draw-wire encoder A50	Performance-Line	Measuring length max. 1.25 m
------------------------------	-------------------------	-------------------------------------

Terminal assignment (analog sensor)

Analog sensor A11 (4 ... 20 mA)			R/I converter					
			Signal:	+V	n.c.	I _{out}		n.c.
			Cable ¹⁾	Core color:	BN	WH		BU
	M12 connector, 4-pin	Pin:	1	2	3	4		

Analog sensor A22 (0 ... 10 V DC)			R/U converter					
			Signal:	+V	U _{out}	0 V		0 V _{out}
			Cable ¹⁾	Core color:	BN	WH		BU
	M12 connector, 4-pin	Pin:	1	2	3	4		

Analog sensor A33 (Potentiometer 10 kΩ)			Potentiometer					
			Signal:	+V	Out	0 V		n.c.
			Cable ¹⁾	Core color:	BN	WH		BU
	M12 connector, 4-pin	Pin:	1	2	3	4		

Top view of mating side, male contact base

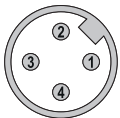

M12 connector, 4-pin

1) Isolate unused cores individually before initial start-up

Linear measuring technology

Draw-wire encoder A50	Performance-Line	Measuring length max. 1.25 m
------------------------------	-------------------------	-------------------------------------

Technology in detail

Wire fastenings

Clip	M4 thread	Eyelet	Carabiner ring
D8.xx1.xxxx.xxxx	D8.xxA.xxxx.xxxx	D8.xxJ.xxxx.xxxx	D8.xxM.xxxx.xxxx

ball-bearing swivel (no torsion of the measuring wire during installation)

rubber stopper

measuring wire

Extension wire

For optimum use of the measuring range by extending the wire length, e. g. to allow realizing a pre-extension in the application. Especially combined with analog interfaces.

Wire types

- V2A, \varnothing 0.5 mm (standard)
- V4A, \varnothing 0.51 mm
- Coramid, \varnothing 0.6 mm
- V4A plastic coated, 1.0 mm (V4A = \varnothing 0.81 mm)

Application-specific installation possibilities

guide pulley

guide pulley

Individual wire outlet

wire outlet at the top 0°
D8.xx1.xxxx.xxxx.xxxx

wire outlet left 270°
D8.xxD.xxxx.xxxx.xxxx

wire outlet right 90°
D8.xxC.xxxx.xxxx.xxxx

wire outlet below 180°
D8.xxE.xxxx.xxxx.xxxx

Individual cable / connector orientation on request

Linear measuring technology

Draw-wire encoder A50 Performance-Line Measuring length max. 1.25 m

Dimensions

Dimensions in mm [inch]

Draw-wire mechanics with encoder

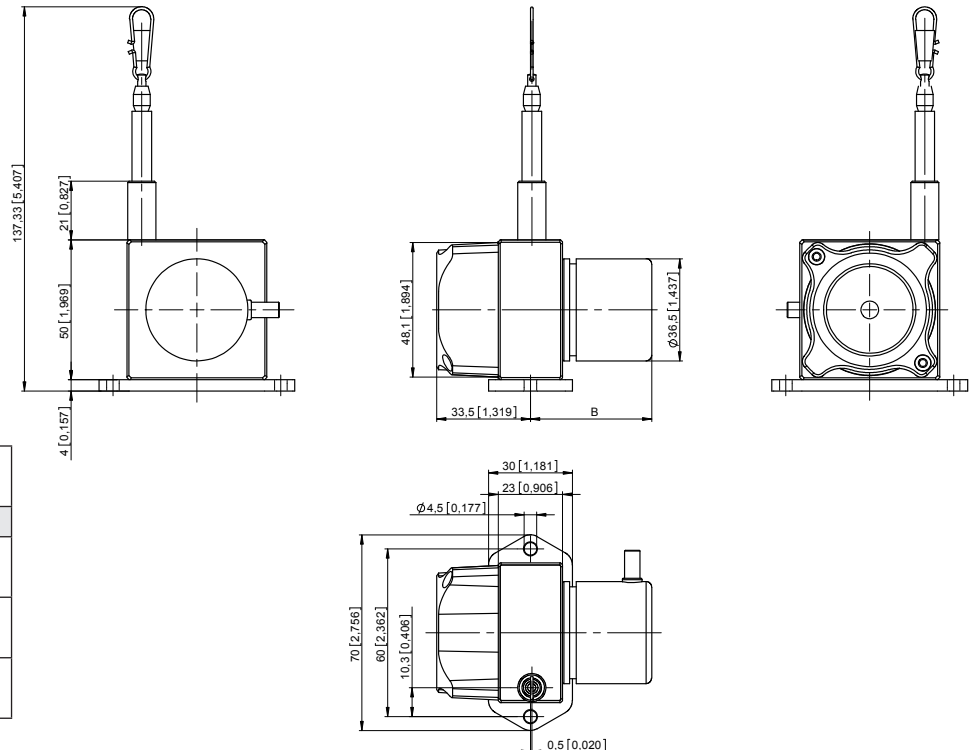

Dimension B depends on the encoder used

Encoder	B
Sendix incremental 3610 D8.6A1.xxxx.36xx.xxxx	43.00 [1.69]
Sendix absolute M366x D8.6A1.xxxx.Mxxx.xxxx	62.45 [2.46]
Sendix absolute F366x D8.6A1.xxxx.Fxxx.xxxx	51.20 [2.02]

Draw-wire mechanics with analog sensor (scaled on measuring range)

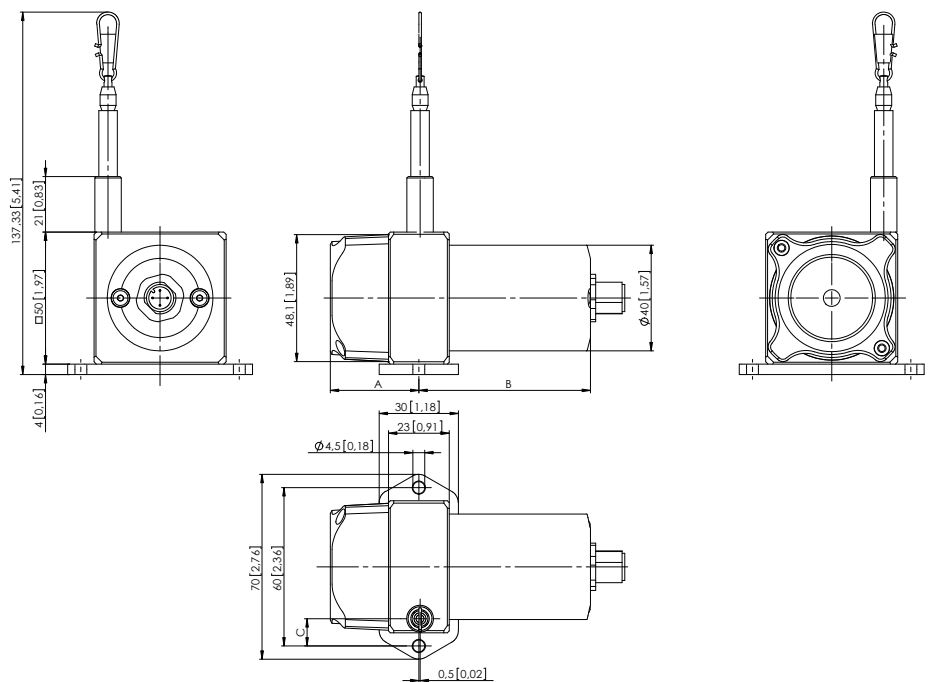

Sensor type	Measuring length	A	B	C
Potentiometer	250 mm	26.5 [1.04]	65 [2.56]	21.30 [0.84]
	500 mm	26.5 [1.04]	65 [2.56]	12.75 [0.50]
	1250 mm	33.5 [1.32]	65 [2.56]	10.30 [0.41]