

**LED temperature controllers** For temperature sensors with limit value (AC+DC) **Codix 564**



The temperature controller Codix 564 displays temperature values in high resolution. In addition it can monitor and control 2 limit values. All current temperature sensors, such as thermocouple types B, E, J, K, N, R, S and T, as well as mV inputs, Pt100 and resistance inputs, can be connected to the device.

These fast displays set new standards when it comes to user friendliness. Their easy-to-read 14-segment LED display, easy-to-understand running help texts and a practical quick-start guide eliminate the need to wade through time-consuming full instruction manuals.

With optional analog output.

<b>DC</b> 10 ... 30 V Supply voltage	<b>AC</b> 100 ... 240 V Supply voltage	<b>A..Z*</b> LEDs 14-segment LED display	<b>Prog</b> Menu-driven programming	<b>mA, Ω</b> Display linearization	<b>Temperature input</b> Temperature input	<b>2, 3, 4</b> 2-, 3-, 4-wire technology	<b>min / max</b> Min / Max value detection	<b>2</b> 2 limit values	<b>AC/DC</b> Galvanic isolation	<b>15 bit</b> Resolution
<b>-20... +65°C</b> Temperature range	<b>DIN 96x48</b> DIN front bezel	<b>Installation in mosaic systems</b>	<b>Operation with gloves</b>	<b>mA, V</b> Analog output optional						

### User-friendly

- Practical quick-start guide for setting the parameters and operating the device.
- Help text as running text.
- Easy-to-read 14-segment LED, 6-digit display, 14 mm high.
- Simple programming via 4 keys on the front.
- One front key as well as 2 additional inputs can be programmed for specific applications.
- Characteristic curves for thermocouples and RTD permanently stored.
- MIN/MAX memory function, individually resettable.

### Powerful

- Sampling rate of 10 readings per second.
- Customized linearization via 12 control points.
- 2 relay outputs (changeover contacts) for limit monitoring with hysteresis and ON/OFF delay function.
- Analog output for the current measured value, MIN-value, MAX-value.
- Auxiliary sensor supply voltage with AC version.
- Inputs and outputs galvanically isolated.
- Digital filter (first-order) for smoothing display fluctuations with unstable input signals.

### Order code

6.564 . 010 . X0X  
a b c d

- a** Input type  
4 = Temperature signal input
- b** Outputs  
0 = relays
- c** Supply voltage  
0 = 100 ... 240 V AC, ±10 %  
3 = 10 ... 30 V DC
- d** Further outputs (optional)  
0 = none  
9 = analog output (only for DC version)

- Delivery specification:**
- Process device
  - Mounting clip
  - Gasket
  - Instruction manual, multilingual
  - 1 sheet of self-adhesive symbols
  - Quick-start guide

Practical quick-start guide for setting the parameters and operating the device. The guide can be affixed directly to the front of the unit and can be removed and re-applied as required.



# Temperature controllers

**LED temperature controllers**

**For temperature sensors with limit value (AC+DC)**

**Codix 564**

## Accessories / Mounting examples

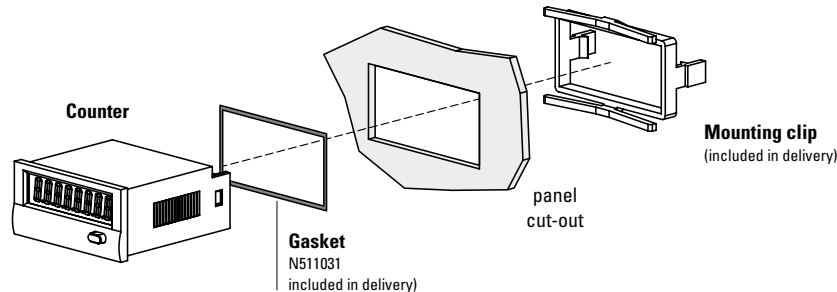

		Type / size	Description		Order no.
<b>Gasket counter</b>			96 x 49 mm [3.78 x 1.93"]		<b>6.0000.1183.1102</b>
<b>Mounting frame</b>		<b>cut-out</b> 92 x 45 mm [3.62 x 1.77"]	for snap-on mounting on 35 mm [1.38"] top-hat DIN rail	grey	<b>6.0000.F100.0001</b>
incl. in delivery					

## Technical data

### General technical data

<b>Display</b>	6-digit, 14 segment LED
<b>Digit height</b>	14 mm [0.55"]
<b>Display range</b>	-199999 ... 999999, with leading zero blanking
<b>Data retention</b>	> 10 years, EEPROM
<b>Operation</b>	5 keys
<b>Operating temperature</b>	-20 °C ... +65 °C [-4 °F ... +149 °F] (non-condensing)
<b>Storage temperature</b>	-25 °C ... +75 °C [-13 °F ... +167 °F]
<b>Relative humidity</b>	93 % (non-condensing)
<b>Altitude</b>	up to 2000 m [6562']

### Electrical characteristics

<b>Supply voltage</b>	AC supply	100 ... 240 V AC / max. 9 VA, 50 / 60 Hz, tolerance $\pm 10$ % ext. fuse protection: T 0.1 A
	DC supply	10 ... 30 V DC / max. 3.8 W with galvanic isolation and reverse polarity protection ext. fuse protection: T 0.4 A
<b>Mains hum suppression</b> (programmable)		50 Hz or 60 Hz
<b>Sensor supply voltage</b>	AC supply	24 V DC $\pm 15$ %, 30 mA
<b>Device safety</b>	designed to protection class application area overvoltage category	EN 61010 part 1 2 (front side) pollution level 2 II

### Mechanical characteristics

<b>Housing</b>	Panel mount housing to DIN 43700 RAL 7021
<b>Dimensions</b>	96 x 48 x 102 mm [3.78 x 1.89 x 4.02"]
<b>Panel cut-out</b>	92 +0.8 x 45 +0.6 mm [3.62 +0.032 x 1.77 +0.024"]
<b>Installation depth</b>	approx. 92 mm [3.62"] incl. terminals
<b>Weight</b>	approx. 180 g [6.34 oz] with analog output 200 g [7.06 oz]
<b>Protection</b>	IP65 (front side)
<b>Housing material</b>	Polycarbonate UL94 V-2
<b>Vibration resistance</b> acc. to EN 60068-2-6	10 - 55 Hz / 1 mm / XYZ 30 min in each direction
<b>Shock resistance</b> acc. to EN 60068-2-27 acc. to EN 60068-2-29	100 G / 2 ms / XYZ 3 times in each direction 10 G / 6 ms / XYZ 2000 times in each direction
<b>Connections</b>	
<b>Supply voltage and outputs</b>	Plug-in screw terminal, 8-pin, RM 5.00, core $\varnothing$ max. 2.5 mm <sup>2</sup> [AWG 13]
<b>Signal and control inputs</b>	Plug-in screw terminal, 9-pin, RM 3.50, core $\varnothing$ max. 1.5 mm <sup>2</sup> [AWG 15]

### Approvals

<b>UL compliant</b> in accordance with	File no. E128604
<b>CE compliant</b> in accordance with	
EMC Directive	2014/30/EU
RoHS Directive	2011/65/EU
Low Voltage Directive	2014/35/EU

# Temperature controllers

## LED temperature controllers

## For temperature sensors with limit value (AC+DC)

## Codix 564

Measuring signal inputs	
<b>Sampling rate</b>	10 readings/sec
<b>Temperature drift</b>	< 100 ppm/K <sub>Ambient</sub>
<b>Input Thermocouple</b>	
thermocouple:	range: accuracy at 23 °C [73.4 °F]:
type B	+250 °C ... 1820 °C [+482 °F ... 3308 °F] typ. 1.0 °C, max. 2.0 °C
E	-200 °C ... +1000 °C [-328 °F ... +1832 °F] typ. 0.2 °C, max. 0.5 °C
J	-210 °C ... +1200 °C [-346 °F ... +2192 °F] typ. 0.2 °C, max. 0.5 °C
K	-200 °C ... 499.9 °C [-328 °F ... +931,82 °F] typ. 0.6 °C, max. 1.0 °C
	-500 °C ... +1372 °C [-868 °F ... 2502 °F] typ. 0.3 °C, max. 0.5 °C
N	-200 °C ... +1300 °C [-328 °F ... 2372 °F] typ. 0.3 °C, max. 0.7 °C
R	-50 °C ... +1768 °C [-58 °F ... +3214 °F] typ. 1.0 °C, max. 2.0 °C
S	-50 °C ... +1768 °C [-58 °F ... +3214 °F] typ. 1.0 °C, max. 2.0 °C
T	-200 °C ... +400 °C [-328 °F ... +752 °F] typ. 0.2 °C, max. 0.5 °C
<b>Resolution J, K, T, E, N</b>	1 or 0.1 °C/°F
<b>Resolution S, R, B</b>	1 °C/°F
<b>Reference point</b>	internal or external constant
<b>Reference point accuracy</b>	≤ ±1 °C
<b>Input mV</b>	
<b>Measuring range</b>	±105 mV (resolution ±15 bit)
<b>Measuring accuracy at 23 °C [73.4 °F]</b> (% of range)	typ. 0.02 / max. ≤ 0.05
<b>Input resistance</b>	> 2 MΩ
<b>Input Pt100</b>	
<b>Measuring range</b>	-200 °C ... +850 °C [-328 °F ... +1562 °F]
<b>Resolution</b>	1 or 0.1 °C / °F
<b>Measuring accuracy at 23 °C [73.4 °F]</b>	typ. 0.3 °C, max. ≤ 0.6 °C
<b>Measuring current</b>	200 µA
<b>Connection</b>	2-, 3-, 4-wire
<b>Lead wire resistance</b>	max. 25 Ω per wire
<b>Input 500 Ω</b>	
<b>Measuring range</b>	0 ... 525 Ω (resolution ±15 bit)
<b>Measuring accuracy at 23 °C [73.4 °F]</b>	typ. 0.1 Ω, max. ≤ 0.2 Ω
<b>Measuring current</b>	200 µA
<b>Connection</b>	2-, 3-, 4-wire
<b>Lead wire resistance</b>	max. 25 Ω per wire

Alarm outputs	
<b>Relays</b>	changeover contacts
<b>Switching voltage</b>	max. 250 V AC / 125 V DC min. 5 V AC / 5 V DC
<b>Switching current</b>	max. 5 A AC / 5 A DC min. 10 mA DC
<b>Switching capacity</b>	max. 1250 VA / 150 W
<b>Pull-in time</b>	approx. 10 ms

Analog output (optional - only for DC version)	
<b>Output ranges</b>	0 (4) ... 20 mA / 0 (2) ... 10 V
<b>Load</b>	current output ≤ 500 Ω voltage output ≥ 2000 Ω
<b>Resolution</b>	15 bit
<b>Update time</b> (basic device measuring rate)	100 ms
<b>Temperature drift</b>	≤ 100 ppm/K <sub>Ambient</sub>
<b>Accuracy</b>	±0.1 % of the output range high value
<b>Output ripple</b>	≤ 10 mV
<b>Isolation voltage</b>	500 V AC for 1 minute or 1 kV DC for 1 second

Control inputs MPI 1 / MPI 2	
<b>Quantity</b>	2 optocouplers
<b>Function</b>	programmable
<b>Switching levels</b>	LOW < 2 V HIGH > 4 V (max. 30 V)
<b>Pulse length</b>	> 100 ms

# Temperature controllers

**LED temperature controllers**

**For temperature sensors with limit value (AC+DC)**

**Codix 564**

## Terminal assignment

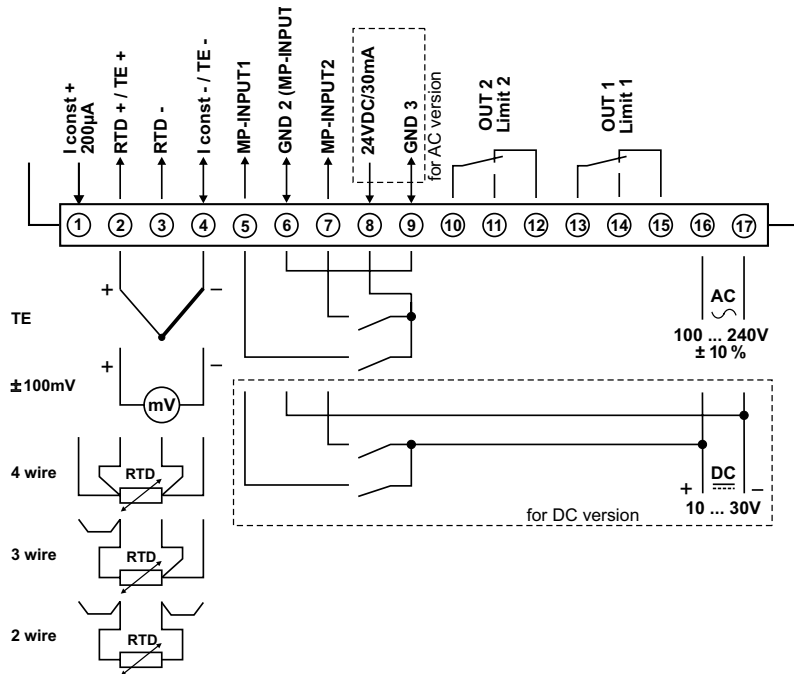

## Rear side view

optional analog output for DC version

- ②⑥ I: 0(4) ... 20 mA
- ②⑤ U: 0(2) ... 10 V
- ②④ GND 5

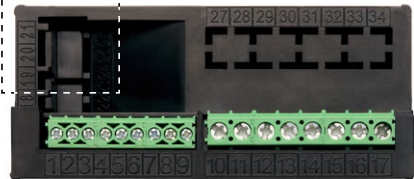

## Block diagram

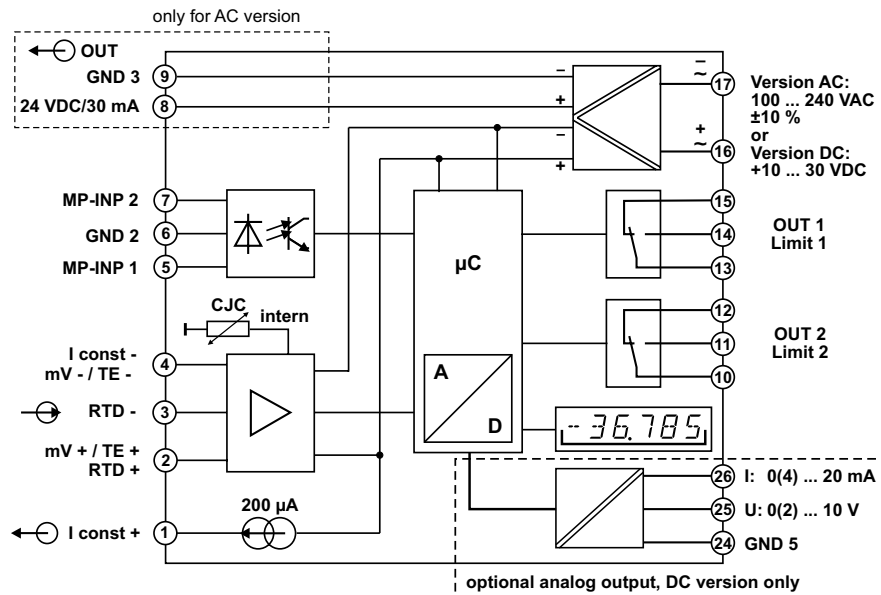

# Temperature controllers

**LED temperature controllers**

**For temperature sensors with limit value (AC+DC)**

**Codix 564**

## Dimensions

Dimensions in mm [inch]

