

Setpoint adjuster

LED setpoint adjuster **Standard signal output for mA or V, also time-controlled (DC)** **Codix 533**



The Codix 533 setpoint adjuster provides a standard signal or a freely programmable, time-controlled signal sequence of 0 to 12 V or 0 to 24 mA.

The setpoint adjuster is a real innovation that opens up new applications in process technology and automation.



DIN 48x24	4 LEDs	10 ... 30 V	Menu-driven programming	High protection level	-20°... +65°C	mA, V	Galvanic isolation

Innovative

- Function of a digital time controller with analog output.
- Manual functions with direct input or stepped incremental output of the setpoint.
- 4-digit, 8 mm high top-quality LED display.
- Physical variables output / 0 ... 12 V or 0 ... 24 mA analog signals.
- Units of display can be freely programmed and displayed – no conversion of the specified output value required.
- Ideal for simulation runs without the need for expensive, time-consuming running-in of processes.

Powerful

- Simpler to run processes than with a PLC or process controller.
- Everything can be programmed easily by means of 2 keys and the text menu.
- Digital setting - no additional DIP switches or potentiometers.
- Display allows simple monitoring of the specified setpoint output.
- User-friendly display form as direct digital value.
- 3 separate functions integrated as standard in the Codix 533.
- High accuracy of < 0.2% of the final value.

Order no.

Setpoint adjuster **6.533.012.300**

Delivery specification

- Setpoint adjuster
- Mounting clip
- Gasket
- Front bezel for screw mounting (T008181) 56 x 40 mm [2.20 x 1.57"], panel cut-out 50 x 25 mm [1.97 x 0.98"]
- Front bezel for clip mounting (T008180) 53 x 28 mm [2.09 x 1.10"], panel cut-out 50 x 25 mm [1.97 x 0.98"]
- 1 set of self-adhesive symbols
- Instruction manual, multilingual

Setpoint adjuster

LED setpoint adjuster **Standard signal output for mA or V, also time-controlled (DC)** **Codix 533**

Accessories / Mounting examples

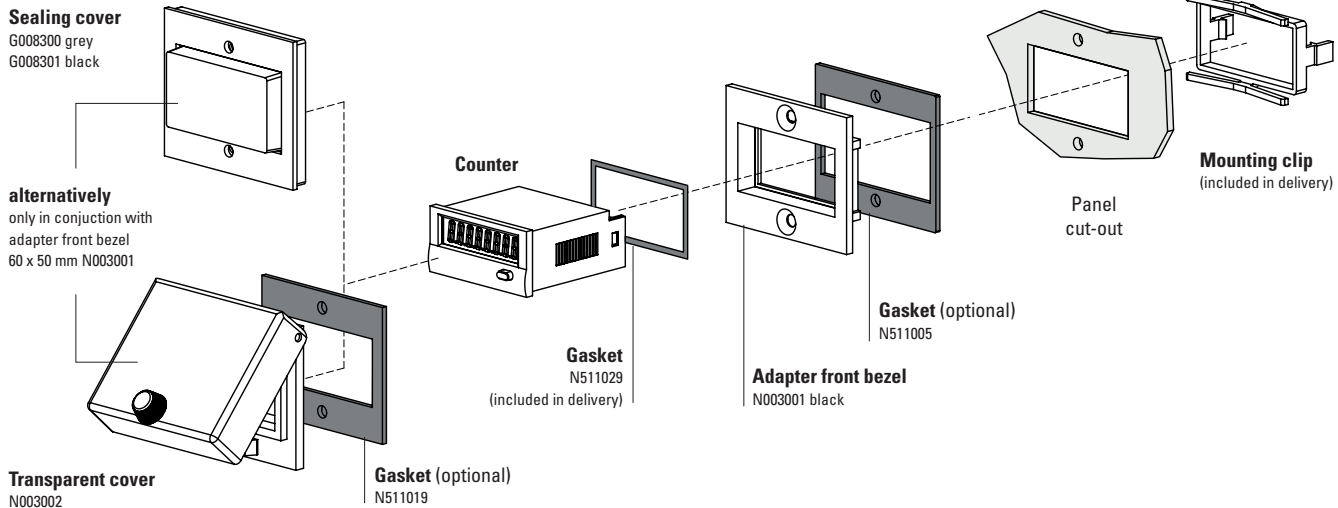

		Type / size	Description		Order no.	suitable gasket
Adapter front bezel		53 x 28 mm [2.09 x 1.10"]	for cut-out 50 x 25 mm [1.97 x 0.98"] to cut-out 45 x 22.2 mm [1.77 x 0.94"]	black anthracite	T008165 T008180	N511015
		56 x 40 mm [2.20 x 1.57"]	for cut-out 50 x 25 mm [1.97 x 0.98"] to cut-out 45 x 22.2 mm [1.77 x 0.94"] screw mounting	black anthracite	T008161 T008181	N511045
		72 x 36 mm [2.83 x 1.42"]	for cut-out 68 x 33 mm [2.68 x 1.30"] to cut-out 45 x 22.2 mm [1.77 x 0.94"]	black and silver anodised as set	162704Set	–
		60 x 50 mm [2.36 x 1.97"]	for cut-out 54 x 29 mm [2.13 x 1.14"] to cut-out 45 x 22.2 mm [1.77 x 0.94"] screw mounting	black	N003001	N511005
		48 x 48 mm [1.89 x 1.89"]	for cut-out 45 x 45 mm [1.77 x 1.77"] to cut-out 45 x 22.2 mm [1.77 x 0.94"]	black	T008883	–
Sealing cover IP65		K1	only in conjunction with adapter front bezel 60 x 50 mm N003001	transparent / grey transparent / black	G008300 G008301	–
Transparent cover IP65		1 Dv (mounted on bezel)	cover lockable, for cut-out 54 x 29 mm [2.13 x 1.14"], only in conjunction with adapter front bezel 60 x 50 mm N003001	transparent / black	N003002	N511019
Gasket counter			48 x 24 mm (for installation in adapter front bezel) 49 x 25 mm		N511029 N511034	
Mounting frame		cut-out 50 x 25 mm [1.97 x 0.98"]	via adapter T008180 for snap-on mounting on 35 mm [1.38"] top-hat DIN rail	chromated	G300004	–
Enclosure blind		48 x 24 mm [1.89 x 0.94"]	for cut-out 45 x 22.2 mm [1.77 x 0.94"] and cut-out 50 x 25 mm [1.97 x 0.98"]	anthracite	G003836	–

incl. in delivery

Setpoint adjuster

LED setpoint adjuster	Standard signal output for mA or V, also time-controlled (DC)	Codix 533
------------------------------	--	------------------

Technical data

General technical data	
Display	4 digits, red 7 segment LED display; 8 mm [0.32"] high
Data backup	EEPROM
Operating temperature	-20 °C ... +65 °C [-4°F ... +149°F] (non-condensing)
Storage temperature	-25 °C ... +85 °C [-13°F ... +185°F]

Electrical characteristics	
Supply voltage	10 ... 30 VDC, galvanically isolated with integrated reverse polarity protection
Power consumption	max. 1 W
Test voltage	500 V, 50 Hz, 1 min.

Mechanical characteristics	
Housing	front panel mount 48 x 24 mm [1.89 x 0.94"] acc. to DIN 43700; RAL 7021, dark grey
Protection	IP65 (front side)
Weight	approx. 50 g [1.76 oz]
Connections	screw terminal, pitch 5.08 mm [2"], 7 pin

Standard signal outputs / control input	
Current output	0 ... 24 mA, increment 10 μ A load 20 mA: \leq 500 Ohm > 20 mA: \leq 400 Ohm
Voltage output	0 ... 12 V, increment 10 mV load \geq 2 kOhm
Control input	HIGH 4 ... 30 V DC Hold (HIGH active) LOW 0 ... 2 V DC
Accuracy	< 0.2% of the full scale value ± 0.02 %/K _{Ambient}

Approvals	
UL compliant in accordance with	File no. E128604
CE compliant in accordance with	
EMC Directive	2014/30/EU
RoHS Directive	2011/65/EU

3 operating modes programmable

Manual direct input (Setp)

- Fast adjustment and manual approach to the desired setpoint value.
- Setpoint value can be specified directly during operation via the keys in V or mA.
- Output of the value 3 seconds after the last key actuation.

Manual ramping function (Man)

- Possibility of a stepped, incremental approach to the desired setpoint value using the keys on the front.
- Input of the minimum and maximum setpoint values and the increment by key actuation in the programming level.
- During operation the device starts with the minimum setpoint value – the right key is used to increase the value by the amount of the increment; the left key decreases the value.
- The programmed maximum value cannot be exceeded.

Automatic ramping function (Auto)

- Function of a digital time based controller with analog output. Setpoint values can be programmed and carried out for process sequences, either cyclic or time dependent: irrigating, dosing, lubricating, filling, venting, mixing.
- With max. 20 current or voltage values.
- Cyclically limited (time) or unlimited.

Example of an automatic ramping function

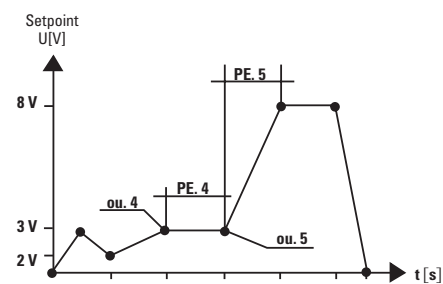

Example with 8 points	
ou. 1	0 V
PE 1	5 s
ou. 2	3 V
PE 2	5 s
ou. 3	2 V
PE 3	10 s
ou. 4	3 V
PE 4	10 s
ou. 5	3 V
PE 5	10 s
ou. 6	8 V
PE 6	10 s
ou. 7	8 V
PE 7	10 s
ou. 8	0 V
PE 8	5 s

Setpoint adjuster

LED setpoint adjuster **Standard signal output for mA or V, also time-controlled (DC)** **Codix 533**

Block diagram

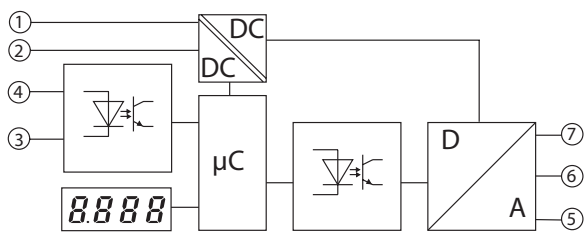

Inputs

1	2	3	4
10 ... 30 V DC	GND_1	GND_2	Hold

Outputs

5	6	7
0 ... 24 mA (Iout)	GND_3	0 ... 12 V DC Uout

Terminal assignment

Inputs

1	2	3	4
10 ... 30 V DC	GND_1	GND_2	Hold

Outputs

5	6	7
0 ... 24 mA	Analog GND_3	0 ... 12 V DC

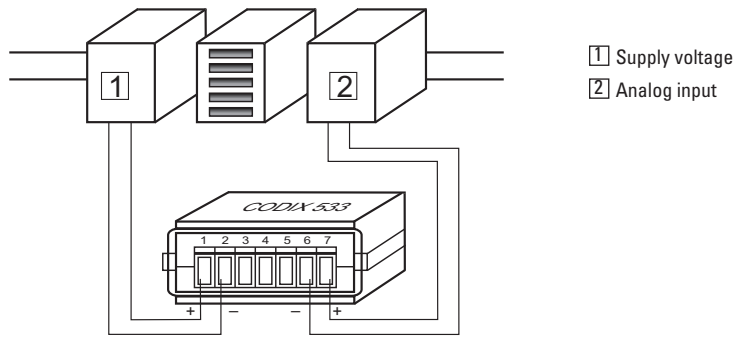

Setpoint adjuster

LED setpoint adjuster **Standard signal output for mA or V, also time-controlled (DC)** **Codix 533**

Dimensions

Dimensions in mm [inch]

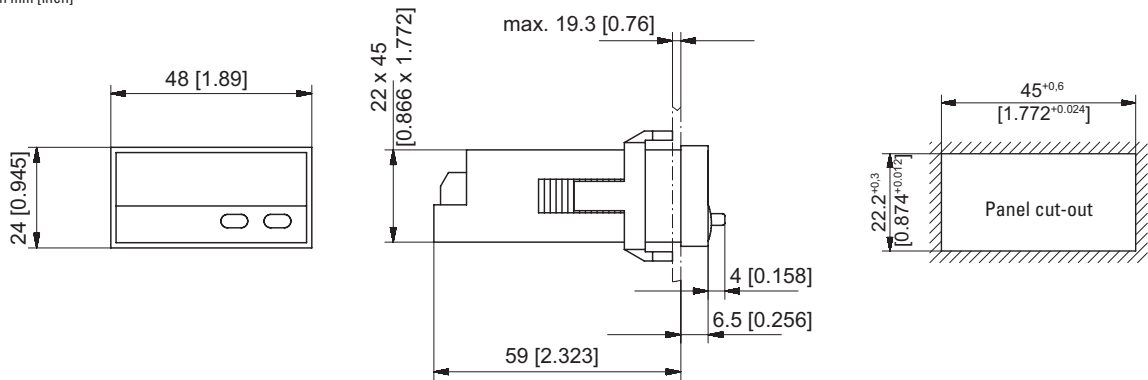

Front bezel

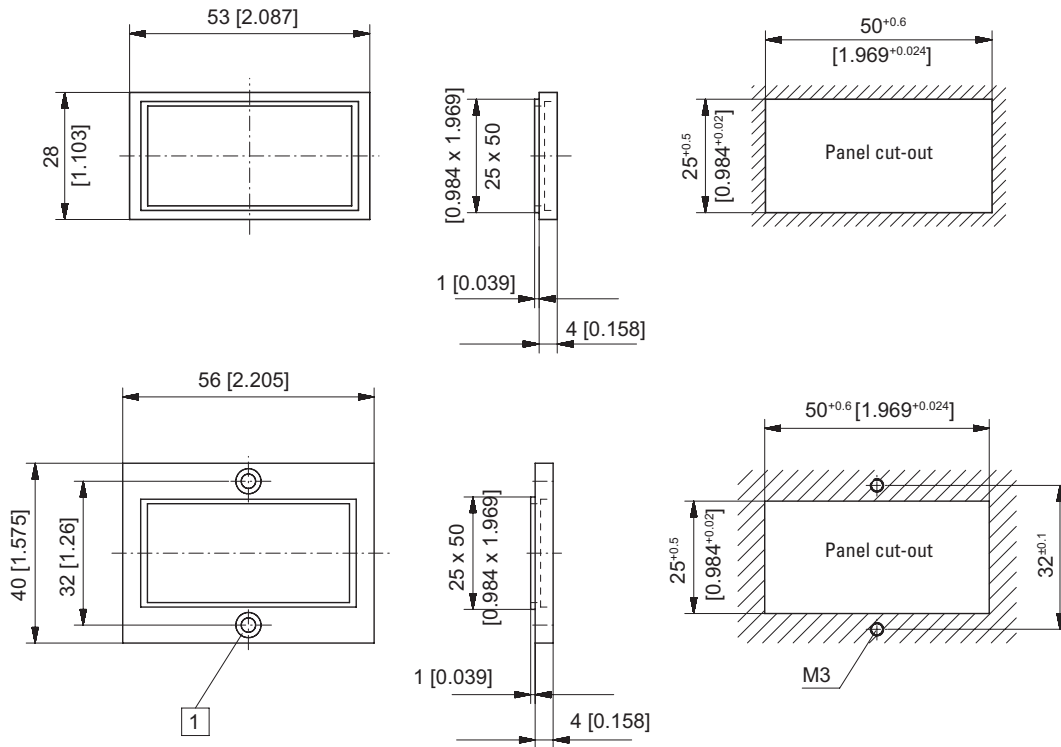

Countersinking Af3, DIN 74

Setpoint adjuster

LED setpoint adjuster

Standard signal output for mA or V, also time-controlled (DC)

Codix 533

Areas of application / Applications

**Simple control (fixed installation)
in plants, machines and devices**

Time-based ramping up or down of:

**For use in set-up mode
of plants, machines and devices**

Manual (direct) specification or time-based or manual setting
(ramping up or down) of:

Rotary speeds (e.g. frequency converter), flow rates, temperatures, positions, pressure and fill levels.
In short: all physical quantities that can be represented with analog standard signals.

Applications

Simple time controller with standard signal output

Commissioning, running-in processes or rotary speed control of motors through setpoint setting.

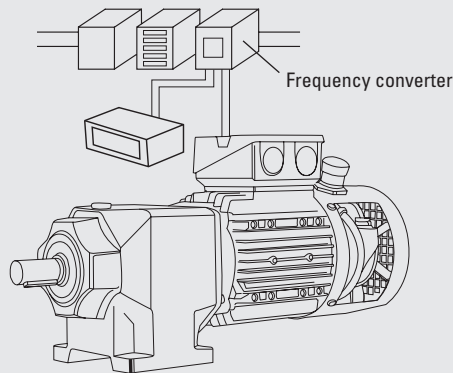

Control of simple, time-based processes by means of an analog signal, e.g. ramping control for locks and sluices

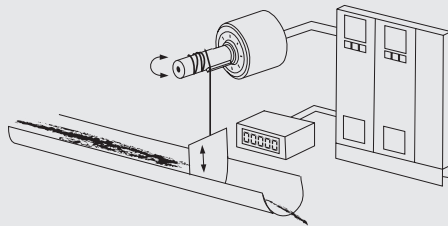

Calibration of filling levels and flow rates: the setpoint adjuster simulates the output signals of a level or flow sensor for configuring a control.

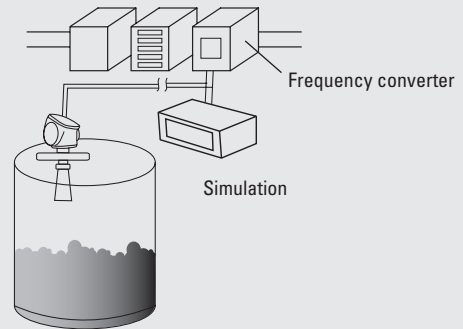

Alignment for temperature-based processes without having to heat up the plant:
the setpoint adjuster can simulate various processes for test purposes.

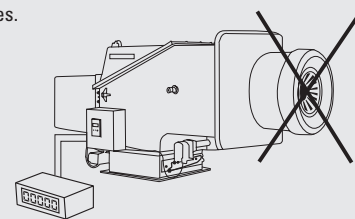

Solution with different modes

2 operating modes are provided for that purpose:

- Manual ramping function
- Automatic ramping function

The following operating modes are provided for that purpose:

- Manual direct input
- Manual ramping function
- Automatic ramping function

Advantages

Instead of using an expensive, complex and difficult-to-use PLC, our setpoint adjuster can handle this task as a standalone device. The user saves costs and the task can be performed in a flexible and quick way, even without any prior knowledge.

The setpoint adjuster simulates the sensor signal that is read by the physical process, e.g. the rise of the temperature, the filling of tank plants. Expensive and complex running-in of processes can be replaced with the simulation performed by the setpoint adjuster.

The output signal can be displayed directly or scaled in any desired unit.
The user always sees the exact progress.
An easy-to-use device with three selectable modes is available.