

Changing the basic function causes all parameters to be reset to factory settings.

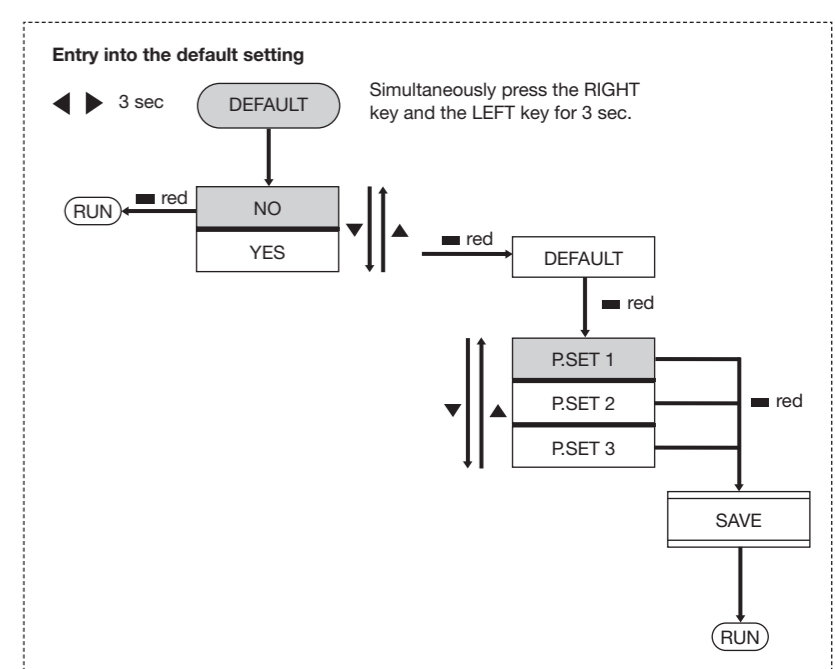

FUNCT. TIMER

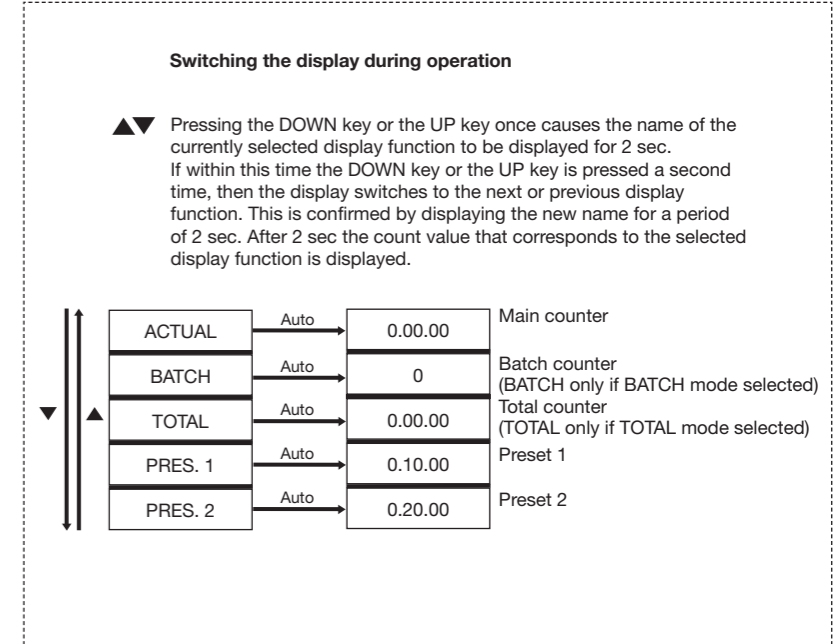
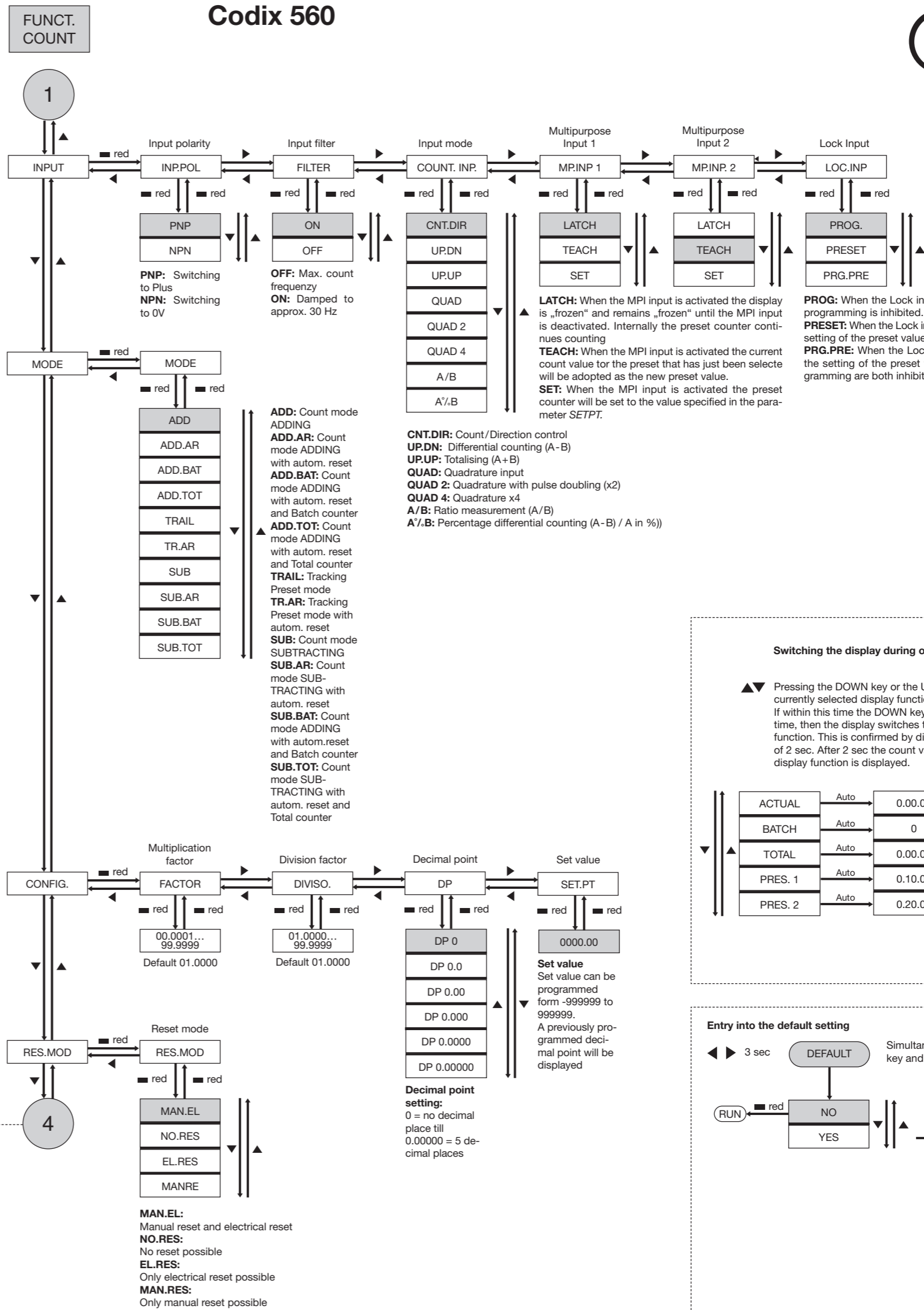
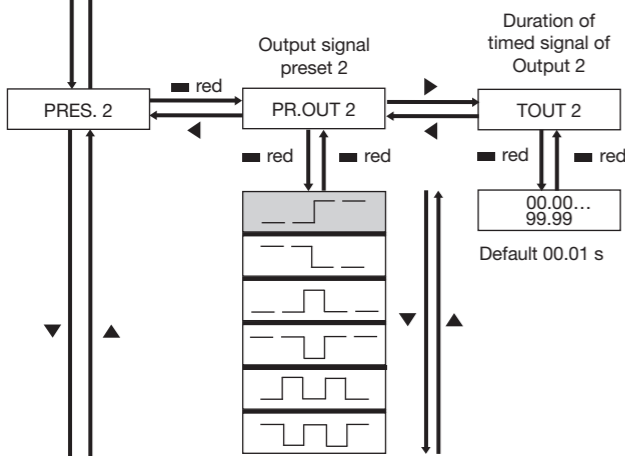
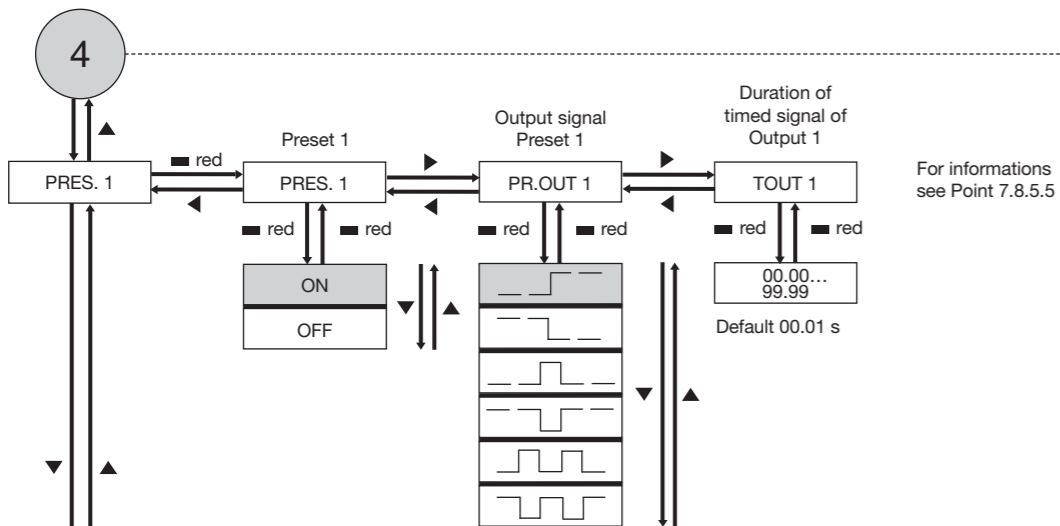
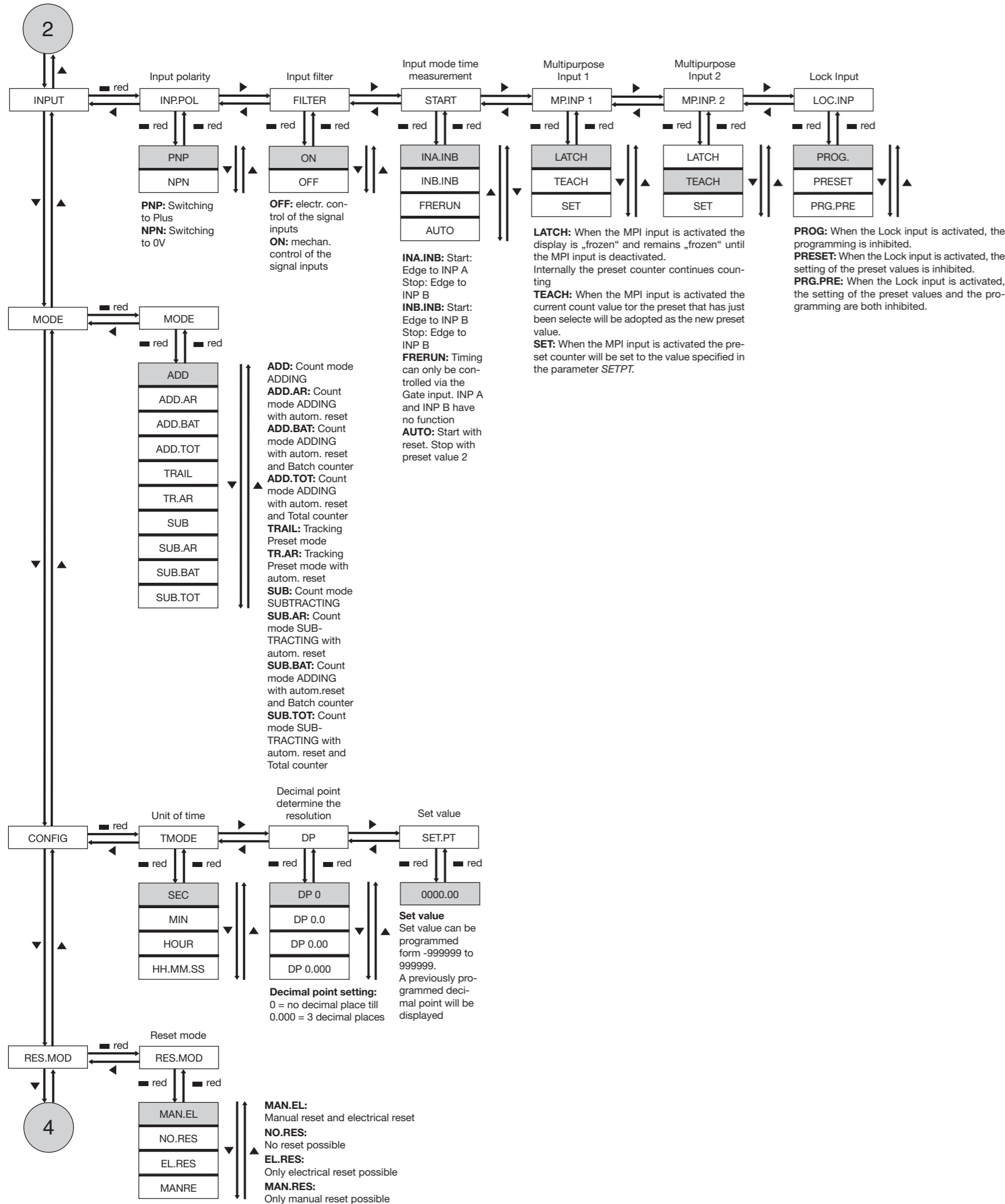

FUNCT. TACHO

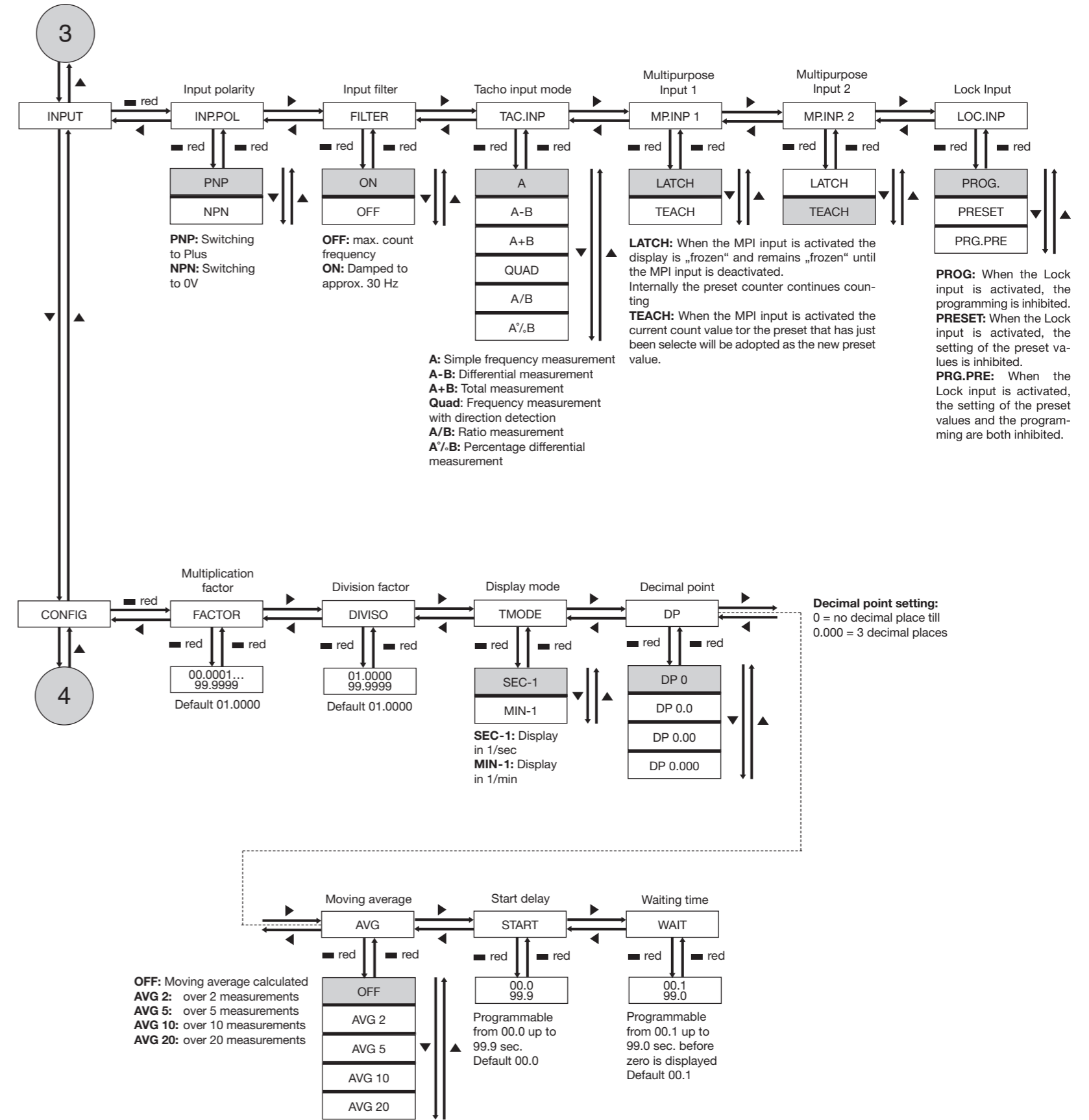

Fritz Kübler GmbH
Zähl- und Sensortechnik
 P.O. BOX 3440
 D-78023 Villingen-Schwenningen
 GERMANY
 Tel. +49 7720/39 03-0
 Fax +49 7720/2 15 64
 sales@kuebler.com
 www.kuebler.com