

LCD Modules – Type 180



Your benefit

- Small dimensions
- PCB mount
- Low current consumption, for battery

Product features

- With manual and/or manual and electrical reset
- Using a lithium battery with 1000 mAh the life is more than 10 years
- CMOS and TTL compatible

Technical data:

Power supply:	3 V (+0.2, -0.6 V) DC
Display:	LCD, 8-digit, figures 8 mm [0.315"] high
Counting system:	adding or subtracting
Inputs:	
Fast count input:	max. count frequency, 10 kHz, min. pulse time 50 μ s Input resistance 1 M Ω switching level: Low: <0.7 V DC High: <2.5 V – UB (without R*) positive triggered see connection diagram
Slow count input:	max. count frequency, 40 Hz min. pulse time 13 ms Input resistance 1 M Ω switching level Low: <0.7 V DC High: <2.5 V – UB, negative triggered
Count direction:	static input, subtracting count as long as the input is 0.

Reset input:	static input, i.e. no count as long as the input is active. please note: the reset input will be active, when switching to 0 V
min. pulse time	12 ms
Input resistance	1 M Ω
Switching voltage	1.4 V negative triggered
Interference resistance:	EN 50081-1
Interference emission:	EN 55022 class B
Operating temperature:	-10 ... +60 °C
Storage temperature:	-20 ... +70 °C
Housing colour:	black
Connections:	1 fast count input 2 slow input D count direction R reset +, – Power supply
Type:	180.2: module with electrical reset 180.3: module with manual and electrical reset

Dimensions:

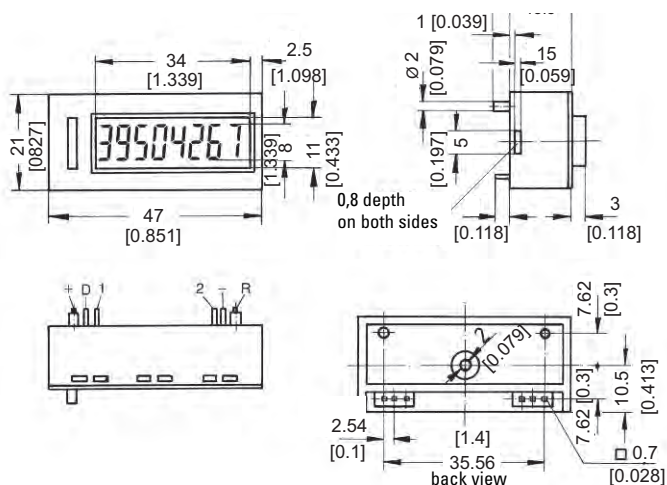

Connections:

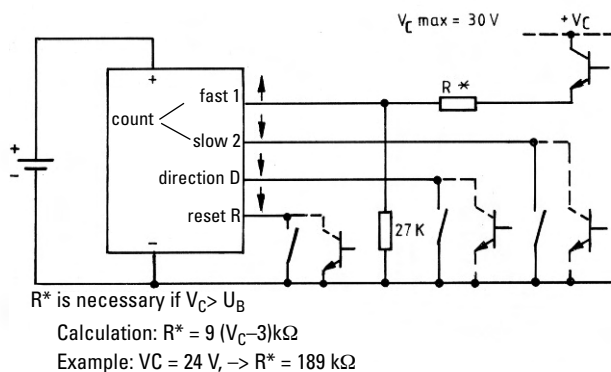

Order code:

Module with electrical reset
Module with manual and electrical reset

Order-No.: 0.180.200.000*
Order-No.: 0.180.300.000*

* standard stock model