

Counters with stepper motor – KWh 17



Product features

- 7-digit drum-type counting mechanism (cyclometer) with pulse control, for installation in kWh meters
- Stepper motor drive
- Each incoming pulse advances the decimal place of the counting mechanism by 1/100 of a revolution



Your benefit

- **5 year warranty***
very reliable: your end product is easier to sell
- Only 25 mW power consumption permits trouble-free PCB mounting
- Data retention on power-failure
- Large digits as with conventional Ferraris meters

Applications:

module for installation in electro-mechanical kWh meters

* for fixed installations and use in accordance with the technical data

Technical data:

Driving mechanism:	stepper motor	stepper motor
Nominal voltage:	5 V DC $\pm 10\%$	10 V DC $\pm 10\%$
Activation:	rectangular- or needle-shaped pulses	Rectangular- or needle-shaped pulses
Electrical connection:	solder pins	Solder pins
Display:	7-digit display, decimal place with additional 1/100 division counter reading on delivery: 000 0001 ± 3 digits	
Figures:	white on black	
Coil resistance:	1 k Ω	3.6 k Ω
Power consumption:	25 mW	28 mW
Height of figures:	5 x 3 mm [0.197 x 0.118"]	5 x 3 mm [0.197 x 0.118"]
Ambient temperature:	-20 ... +70 °C [-4 ... 158 °F]	-20 ... +70 °C [-4 ... 158 °F]
	non condensing	non condensing
Relative humidity :	< 95% (no condensation)	

Options:

Different mounting possibilities:	on request
Magnetic shield:	with or without
Alternative operating voltage:	on request
Alternative coil resistance:	on request
Extended temperature range:	-40 ... +90 °C [-40 ... 194 °F]

Pulse diagrams:

Rectangular shaped pulses

Pulses by capacitor charge or discharge

Recommended Capacitor
5 V DC version 100 μ F
10 V DC version 33 μ F

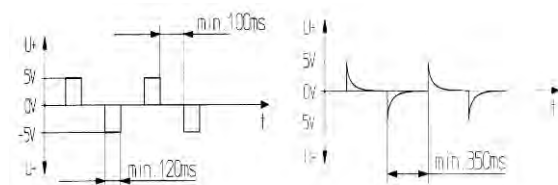

Counters with stepper motor – KWh 17

Dimensions:

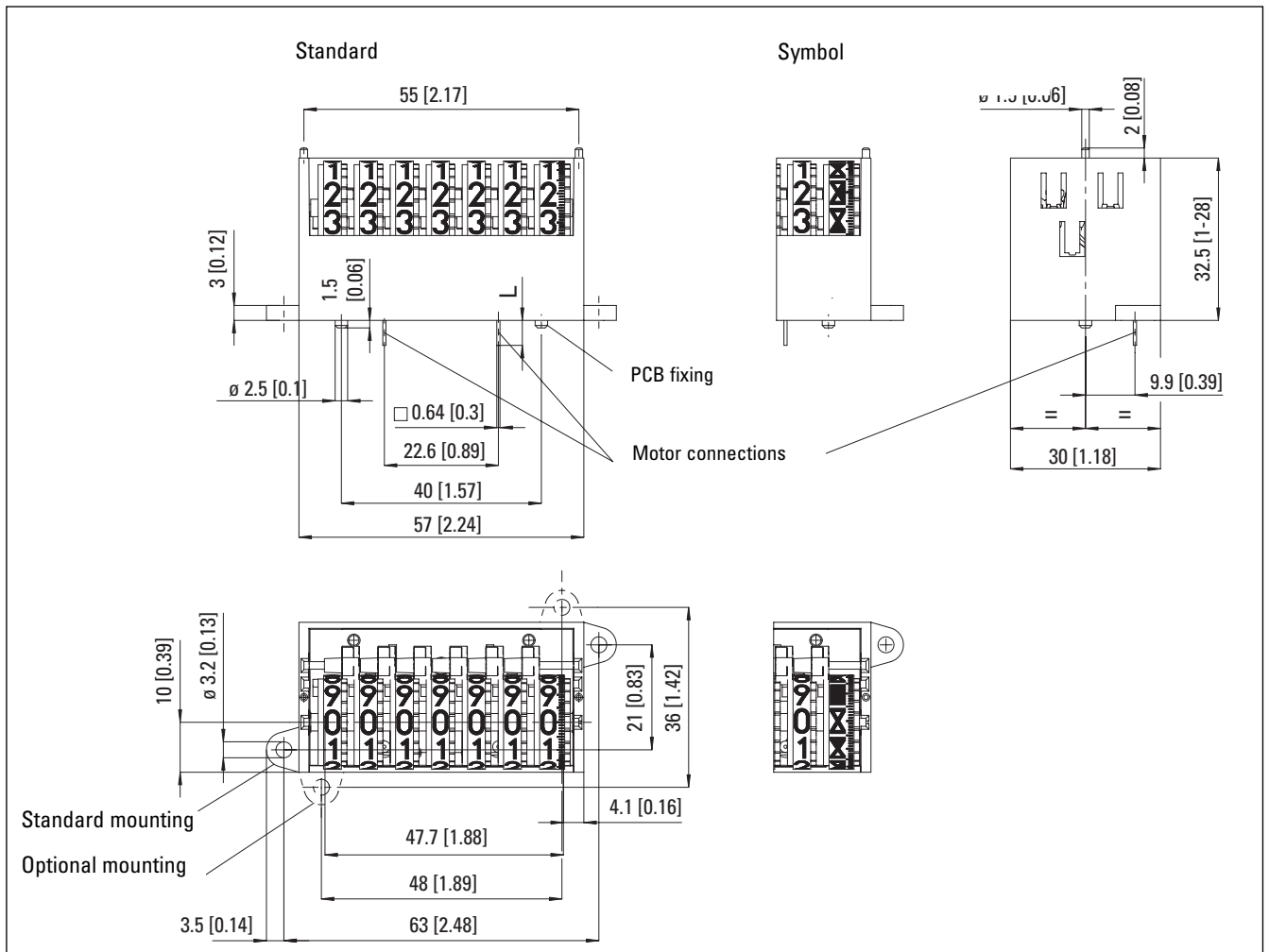

Order Code:

1.94X.XXX.XXX.XXX

