

## CODIX 553 with 2 limit values



Available with serial interface and set-up software EzControl!

### Your benefit

- Programmable input characteristic curve with up to 24 control points
- MIN/MAX value acquisition and data backup in case of Power Off
- Display-Hold or reset input for the limit values
- Very big keys for use with gloves
- Input for key-lock
- Very bright display

- Input range  
0 ... 20 mA, 4 ... 20 mA; 0 ... 10 V  
2 ... 10 V;  $\pm 10$  V
- Outputs  
2 limit values with programmable hysteresis and programmable signal behaviour, relays with change-over contact or optocoupler

### More advantages

- Auxiliary power supply output for measuring transducer/sensor
- Optional serial interface

### Technical data

#### Miscellaneous Data

Display	5-digit display, red 7-segment LED's; height 14.2 mm [0.559"]
Display range	-19999 ... 99999, with leading zeros suppression
Out of Range Indication	Under-range uuuu / Over-range ooooo
Data storage	EEPROM, 1 Million storage cycles or 10 Years
Test voltages	EN 61010 Part 1 ; overvoltage category 2, level 2
EMC	Interference emissions EN 55011 Class B Interference resistance EN 61000-6-2

AC power supply	90 ... 260 V AC/max. 6 V A external fuse 100 mA/T
DC power supply	10 ... 30 V DC, max. 2 W, galvanically isolated with inverse polarity protection external fuse 250 mA/T
Mains Hum Filter	digital filter 50 Hz or 60 Hz, programmable

#### Measurement ranges

Current input (DC)	Ranges 0 ... 20 mA, 4 ... 20 mA
Resolution	2 $\mu$ A
Voltage drop	max. 2 V at 20 mA
Max. current	50 mA
Voltage input(DC)	Ranges 0 ... 10 V, 2 ... 10 V, $\pm 10$ V
Resolution	1 mV
Input resistance	> 2 M $\Omega$
Max. voltage	$\pm 30$ V
Measuring speed	approx. 2 measurements/s
Linearity	< 0.1% $\pm 1$ Digit for the whole measuring range at an ambient temperature of 20°C [68 °F]
Zero calibration	automatic
Temperature drift	100 ppm/K

Weight	approx. 220 g [7.76 oz]
Protection	IP 65 (front)
Ambient temperature	-20 ... +65 °C [-4 °F ... 149 °F]
Storage temperature	-40 ... +85 °C [-40 °F ... 185 °F]

#### Digital inputs

Input MPI*	Function of the input is dependent on set up
1. Function Display-Hold	to stop the instantaneous value
2. Function Reset	Reset the alarm value
Alarm Latch	

#### Outputs

##### Alarm 1/Alarm output 2

Relay output	with volt-free changeover contacts can be setup as normally closed or normally open
Switching voltage	250 V AC/300 V DC
Switching current	max. 3 A AC/DC, min. 30 mA DC
Switching power	2000 VA / 50 $\Omega$

or NPN-optocoupler with open collector and open emitter

Switching power 30 V DC/15 mA

#### Auxiliary power supply output for measuring transducer/sensor

AC models	voltage output 10 V DC $\pm 2\%$ , 30 mA and voltage output 24 V DC $\pm 15\%$ , 50 mA
DC models	only voltage output 10 V DC $\pm 2\%$ , 30 mA

#### Interface

Available options	RS232, RS485, RS422
Baud rate	600, 1200, 2400, 4800, 9600, 19 200 programmable
Address	00 ... 99 programmable

\*MPI: Multi Purpose Input

### Dimensions:

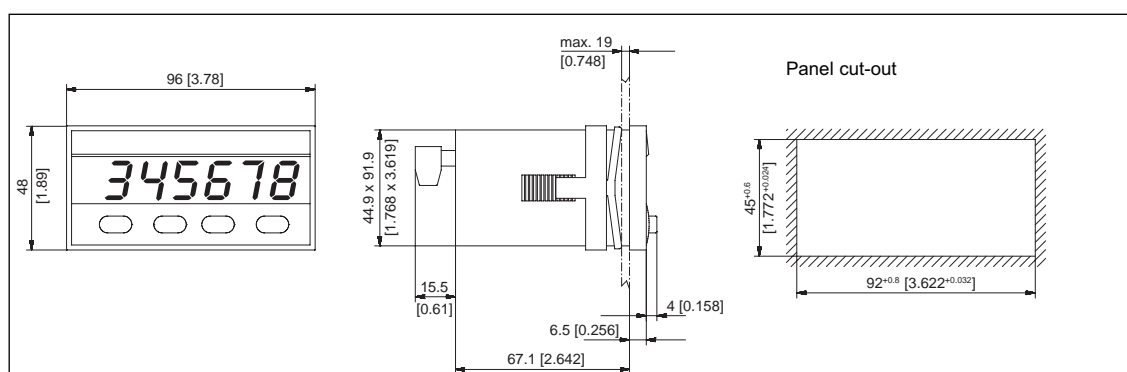

## CODIX 553 with 2 limit values

### Connections:

#### Rear side view

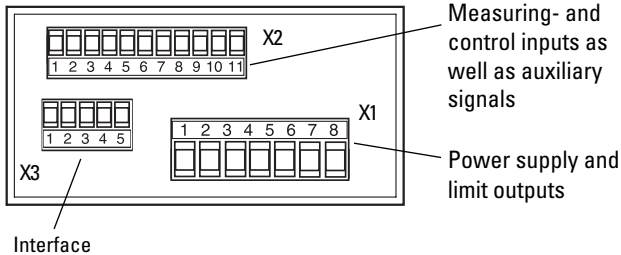

#### Power supply and alarm outputs

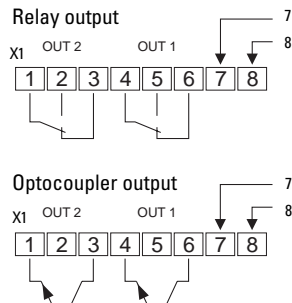

	DC version	AC version
7	10 ... 30 V DC	90 ... 260 V AC (N~)
8	GND4 (0 V DC)	90 ... 260 V AC (L~)

#### Current measurement

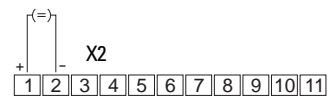

1	Current input (I) 0 ... 20 mA / 4 ... 20 mA
2	GND1 (Analog)

#### Voltage measurement

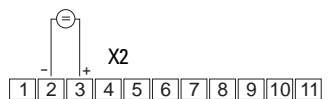

2	GND1 (Analogue)
3	Voltage input (U) 0 ... 10 V, 2 ... 10 V, -10 ... +10 V

#### Control inputs and auxiliary power supply (U<sub>out</sub>)

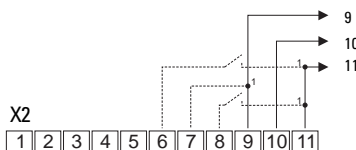

1) Alternatively connect directly to DC supply (galvanic separation of control and measurement inputs)

9	GND3 (for U <sub>out</sub> )
10	U <sub>out</sub> +10 V/30 mA
11	U <sub>out</sub> +24 V/50 mA only for power supply 90 ... 260 V AC
8	MP-Input "Reset-Alarm-Latch/Display-Hold"
7	GND2 (KEY/MPI)
6	Keypad lock-out "Key"

#### Interface

X3 1 2 3 4 5

	RS232	RS485	RS422
1	GND	-	-
2	RxD	DO+/RI+	RI+
3	TxD	DO-/RI-	RI-
4	-	-	DO+
5	-	-	DO-

#### Application:

- Level measurement
- Flow measurement
- Pressure measurement
- Revolution measurement
- Speed control in conjunction with the 0... 10 V outputs from inverters
- Programming and readout of values via PC

#### Serial interface

- For data transmission and documentation
- Connection for programmable logic controllers
- Programming via PC

#### Delivery includes:

- Process display
  - Screw terminal, 8-pole, RM 5.08
  - Screw terminal, 11-pole, RM 3.81
  - Screw terminal, 5-pole, RM 3.81(\*)
  - Clamping bracket
  - Gasket
  - Multilingual operating instructions
  - 1 set of self-adhesive symbols
- \* only with the interface option

#### Order code:

6.553.01X.X0X

