

# Linear Measuring Technology

**Elevator Measuring System for Shaft-copying**

**Encoder mounting fixture, circumferential, LM5**

**max. height 120 m**

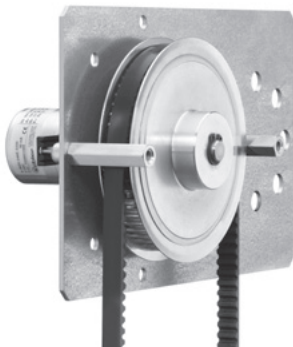

System for shaft-copying, with complete mechanical kit in proven toothed belt technology.

A smooth-running toothed belt and a vibration-resistant encoder mounting fixture ensure quiet operation. The belt pulley benefits from separate bearing supports in the mounting fixture, so protecting the installed encoder from mechanical overloading. An encoder mounting fixture with measuring wheel is located at both the top and the bottom of the elevator shaft. The encoder can be mounted on top or bottom.



Ideal for use in passenger elevators, freight elevators, automatic storage systems.

## Reliable

- Rugged construction
- Reduced load on encoder bearings due to separate belt pulley-bearings
- Non-slip
- Tensioning rollers with belt guide
- Separation of bearing load and sensor technology ensure high level of protection for the installed encoder.
- Mounted hollow shaft encoder

## Minimal noise generation

- Smooth-running toothed-belt ensures extremely quiet operation
- Vibration-free operation

**Order-No.**

**8.LM5.01**

**Encoder mounting fixture with measuring wheels for fixing on the elevator car**

*consists of:*

- 2 x Encoder mounting fixture with mounted measuring wheel
- Belt guide
- Follower bracket set for toothed belt
- Belt fixing and tensioning set
- Screws and other small components

*suitable encoders:*

- Incremental encoder: 8.3620.24XX.XXXX

Calculation of pulse rate PPR =

$$\frac{300 \text{ mm}}{\text{Resolution, e.g. } 0.5 \text{ mm}} = 600$$

- Absolute encoders:

SSI: 8.F3683.33XX.XXXX

CANopen: 8.F3688.37XX.XXXX

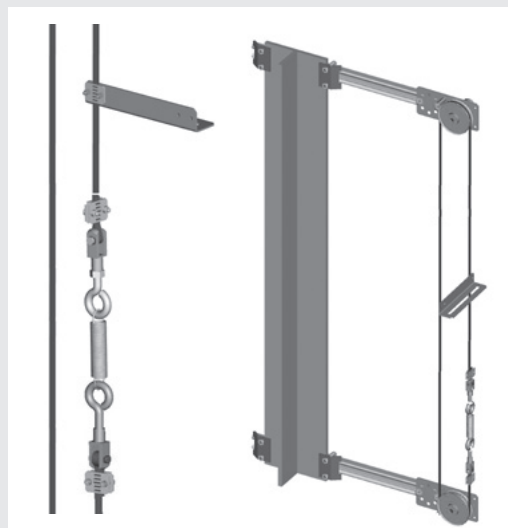

# Linear Measuring Technology

## Elevator Measuring System for Shaft-copying Encoder mounting fixture, circumferential, LM5 max. height 120 m

### Accessories for encoder mounting fixture LM5

**Fixing kit**

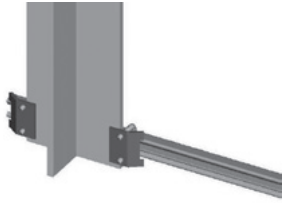

Complete kit consists of:

- C-rails, 700 mm
- 4 x carrier clamps

**8.BLM6.01**

**Toothed belt**



- Width 10 mm
- Polyurethane, with single parallel steel cords.
- Low belt-stretch
- High resistance to abrasive wear
- Resistant to the effects of UV radiation
- Maintenance-free
- Resistant to ageing
- Temperature range -10°C...+80°C

Calculation of the required length of toothed belt = Elevator height + approx. 5 m (depending on the distance between top and bottom fixing)

**05.ZAR1.XXX**

XXX = Length in metres  
Standard delivery lengths:  
20 m, 25 m, 30 m, 35 m, 40 m, 45 m, 50 m, 55 m, 60 m, 70 m, 80 m, 90 m, 100 m, 120 m, 250 m, 300 m  
Other lengths on request

General technical data	
Resolution in the shaft	depends on the resolution of the encoder (e.g. incremental encoder with 3000 PPR = 0.1 mm; absolute encoder 12 x 12 bit < 0.1 mm)
Elevator car speed	max. 5 m/s
Max. height of elevator	120 m
Effective circumference of belt pulley	300 mm

### Dimensions

