

Rotary Measuring Technology

Absolute encoders, Multiturn, with optional incremental track

Multiturn Type 9081 SSI or RS 485, programmable



- Hollow shaft up to $\varnothing 28$ mm or shaft $\varnothing 12$ mm
- Only 50 mm clearance needed
- Programming parameters include*: code type, resolution per revolution, total resolution, direction of rotation (cw or ccw), zero point.
- Very easy mounting of the hollow shaft version. The encoder is mounted directly on the drive shaft without couplings. This saves up to 30 % cost and 50 % clearance

* with optional programming kit (Ezturn®) see accessories

- compared to shaft versions.
- Max. 4 programmable outputs* for the SSI version
- Divisions: 8192 (13 bits) per revolution, 4096 (12 bits) revolutions
- Electronic multiturn gear with patented intelligent sensing technology (IST)
- optional with incremental track 2048 ppr.

Mechanical characteristics:

Speed: ¹⁾	max. 6000 min ⁻¹
Rotor moment of inertia:	approx. 65×10^{-6} kgm ²
Starting torque hollow shaft version:	< 0.2 Nm
Starting torque shaft version:	< 0.05 Nm
Radial load capacity of shaft (hollow shaft): ²⁾	80 N
Axial load capacity of shaft: (shaft): ²⁾	40 N
Weight:	approx. 0.7 kg
Protection acc. to EN 60 529:	IP 65
Working temperature:	-20° C ... +70 °C ³⁾
Shaft:	stainless steel H7
Shock resistance acc. to DIN-IEC 68-2-27	2500 m/s ² , 6 ms
Vibration resistance acc. to DIN-IEC 68-2-6:	100 m/s ² , 10 ... 2000 Hz

- 1) For continuous operation 3000 min⁻¹
 2) At shaft version only (at shaft end)
 3) Non-condensing

Electrical characteristics:

Interface type:	Synchronous-Serial (SSI) with outputs
General:	
Supply voltage (U _B):	5,0 ... 30 V DC ³⁾
Current consumption type (no load):	89 mA
max (no load):	138 mA
Short circuit proof outputs: ¹⁾	yes ²⁾
Reverse connection protection at U _B :	yes
SSI-Interface:	
Output driver:	RS 485
Permissible load/channel:	max. +/-20 mA
Update rate for position data:	approx. 1600/s
SSI pulse rate min./max./pulse frequency:	100 kHz/500 kHz
Signal level high:	typ. 3.8 V
Signal level low (I _{Last} = 20 mA):	typ. 1.3 V
Rise time t _r (without cable):	max. 100 ns
Fall time t _f (without cable):	max. 100 ns
Control inputs:	Voltage: 5 ... 30 V DC = U _B
(V/R, SET)	Response time: 10 ms
	Signal level: low max. 25% U _B
	high min. 60% U _B , max. U _B
	Max. current load £0.5 mA

The programmable SSI versions are available in 3 variants:

Order code Interface 2:

Version with 4 programmable outputs

Order code Interface 5:

Version with incremental outputs $\bar{A}, \bar{A}, \bar{B}, \bar{B}$ (no programmable outputs)

Order code Interface 9:

Version with 2 programmable outputs and 2 sensor outputs for 0 V and +U_B for controlling the supply voltage on the encoder.

Status outputs:	Output driver:	Push-Pull
	max. permissible load:	±9.0 mA
	Signal level high:	min. U _B - 2.8 V
	low:	max. 1.5 V
	Rise time:	max. 1 µs
	Fall time:	max. 1 µs

Incremental outputs (A/B):	Output driver:	RS422 compatible
	Pulse frequency (max.):	200 kHz
	Signal level high:	4.5 V
	Signal level low (I _{Last} = 20 mA):	0.5 V
	Rise time (without cable):	max. 200 ns
	Fall time (without cable):	max. 200 ns

Conforms to CE requirements acc. to EN 61000-6-2, EN 61000-6-4 and EN 61000-6-3

Performance against magnetic influence acc. to EN61000-4, 5

UL certified File 224618

RoHS compliant acc. to EU guideline 2002/95/EG

- 1) If U_B supply voltage correctly applied U_B
 2) Only one channel allowed to be shorted-out:
 If U_B = 5 V DC, short-circuit to output, 0 V and + U_B is permitted.
 If U_B < 5 V DC short-circuit to output and 0 V is permitted.
 3) The supply voltage at the encoder input must not be less than 4.75 V (5 V - 5%)

Multiturn Type 9081 SSI or RS 485, programmable

Control inputs:

F/R input for change of direction:

The encoder can output increasing code values when the shaft is rotated either clockwise or counter-clockwise (when looking from the shaft side).

There are two methods for selecting the appropriate option:

1. Via a hardware configuration of the F/R input BEFORE powering up the encoder
2. By programming the device using the Kübler "Ezturn®" programming tool.

The following table shows the function selection dependent on hardware and software settings:

Hardware configuration of the F/R input:

Hardware configuration of the F/R input	Programmed selection using the Ezturn® programming tool	Function: increasing code value when the shaft is in the following direction:
"low" (0V) on the F/R input (=cw)	cw	cw
"high" (+UB) on the F/R input (= ccw)	cw	ccw
"low" (0V) on the F/R input (=cw)	ccw	ccw
"high" (+UB) on the F/R input (= ccw)	ccw	ccw

Notes:

- Any hardware configuration of the F/R input must take place BEFORE powering up the encoder!
- If the F/R input is not configured, then a 0V configuration will apply (default condition)!
- If the direction of rotation is changed due to the F/R configuration, without activating the SET function again, and if the encoder is also then powered up again, a new position value may be outputted, even if the physical shaft position of the encoder has not moved! This is due to internal conversion processes.

The start-up procedure for the encoder should therefore follow this sequence:

1. Determine the count direction of the encoder either via the F/R input or via programming
2. Apply power to the encoder
3. Activate the SET function, if desired (see SET input below)

- If using a cable wire to configure the F/R input, then for EMC reasons the wire should not remain open but should be tied either to 0V or UB!
- The response time of the F/R input with UB = 5 ... 30 V DC power supply is 10 ms.

SET input:

This input is used for a one-time alignment (zeroing) of the encoder immediately after installation. A high control pulse (+UB) applied to this input for a minimum of 10 ms will reset the current encoder position to the pre-programmed setpoint value.

The programming of the setpoint can be carried out with Kübler's Ezturn® programming software or can, on request, be done in advance at the factory. The default value is zero. However any value within the encoder's measuring range can be defined.

Notes:

- The SET function should only be implemented when the encoder shaft is at rest.
- For the duration of the SET pulse the SSI interface does not function and therefore does not output any valid position values! In order to avoid malfunctions, no SSI clock pulse should occur during the SET pulse.

- If a cable wire is used to configure the SET input, then for EMC reasons the wire should not remain open but should if at all possible be tied to 0 V, provided no SET pulse is triggered!
- The response time of the SET input with +UB = 5 ... 30 V DC power supply is 10 ms.

Encoder outputs¹⁾

Output	Default-function:
A1:	battery control ²⁾
A2:	not activated ²⁾
A3:	not activated ²⁾³⁾
A4:	not activated ²⁾³⁾

The outputs are not activated in the factory setting (default). They can be activated and defined with the optional Ezturn® programming software e.g. limit switch, overspeed and temperature control etc.

³⁾ with the order code Interface 9 assigned to the sense outputs.

¹⁾not available for versions with incremental track

²⁾programmable with the optional programming software Ezturn®

Functionality of the Ezturn® software

- Setting of the communication parameters
- RS232 encoder/PC interface
- Setting of a drive factor by means of the modification of the resolution per revolution, the number of revolutions and the total resolution
- Programming of the direction of rotation and code type
- Setting of a preset/electronic zero point
- Setting of diagnostic functions
- Setting of the outputs A1 ... A4
 - Limit switch values, max. 2
 - Alarm and status information
 - Battery monitoring
- Limiting max. number of bits to interface with PLCs
- Diagnostics and information for the set-up operation
- Data transmission from the PC to the encoder and inversely, also during operation
- Print-out of the current data and set parameters
- Convenient position output with the current set data
- Terminal operation for direct instructions via the keyboard
- Diagnostics of the encoder connected

Rotary Measuring Technology

Absolute encoders, Multiturn, with optional incremental track

Multiturn Type 9081 SSI or RS 485, programmable

Terminal assignment (SSI Synchronous Serial interface with 12pin plug)

Signal :	0V	+UB	+T	-T	+D	-D	ST	VR	A1	A2	A3 ¹⁾	A4 ¹⁾	⏏
Interface 9:										0 V _{sense}	+UB _{sense}		
Pin:	1	2	3	4	5	6	7	8	9	10	11	12	PH
Col.:	WH	BN	GN	YE	GY	PK	BU	RD	BK	VT	GY PK	RD BU	

T: Clock signal
D: Data signal
ST: SET input. The current position value is stored as new zero position (or the actual value is set to the preset value when using the programmable version).
VR: Up/down input. As long as this input is active, decreasing code values are transmitted when shaft turning clockwise.
PH: Plug housing
Isolate unused outputs before initial start-up.
A1, A2, A3, A4: outputs, can be modified using Ezturn

Terminal assignment (RS485 interface 12 pin plug):

Signal :	0V	+UB	T/R-	T/R+	Term ²⁾	Term ²⁾	VR						⏏
Pin	1	2	3	4	5	6	7 ¹⁾	8	9	10	11	12	PH
Col.:	WH	BN	GN	YE			RD						

R = Receive-channel
T = Transmit-channel
VR: Up/down input. As long as this input (High-Level = +UB) is active, decreasing code values are transmitted when shaft turning clockwise.
PH = Plug housing
1) There is no SET input for the P3001 version but it can likewise be implemented using the command "<ESC> QP" (Write preset).
2) For the version with external termination: if the termination is desired (terminating resistor 120 Ohm), then both connections are to be tied together by means of a jumper (0 Ohm).

Top view of mating side:
12 pin plug

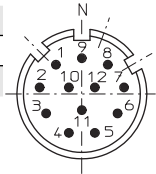

SSI interface with incremental track (A/B):

Signal :	0V	+UB	+T	-T	+D	-D	ST	VR	B̄	B	Ā	A	⏏
Pin	1	2	3	4	5	6	7*	8	9	10	11	12	PH

Dimensions:

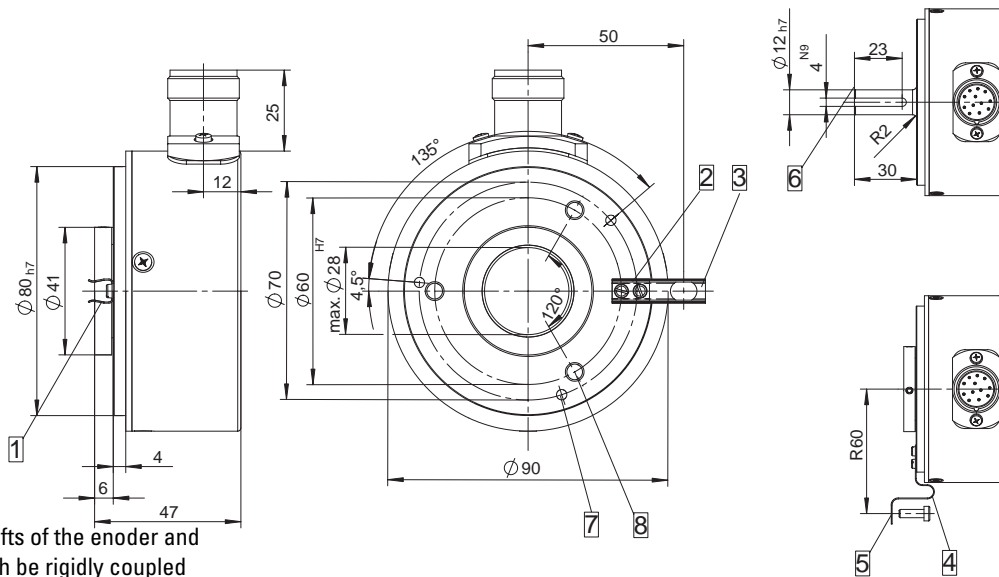

Mounting advice:

- 1) The flanges and shafts of the encoder and drive should not both be rigidly coupled together at the same time! We recommend the use of suitable couplings (see Accessories section).
- 2) Delivery includes a corresponding cylindrical pin (see drawing), when the encoder is ordered with flange type 2 (short spring device) or type 3 (long spring device).

- 1 Spring element for cyl. pin DIN 6325 ø 6
- 2 Spring element short (Flange No. 2)
- 3 Spring element long (Flange No. 3)
- 4 Flange (Flange No. 4)
- 5 Slotted hole for screw M4
- 6 2.5 mm deep
- 7 M4 - 7 deep
- 8 M6 - 10 deep

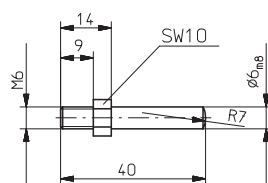

Multiturn Type 9081 SSI or RS 485, programmable

Order code:

8.9081.XXXX.XXXX

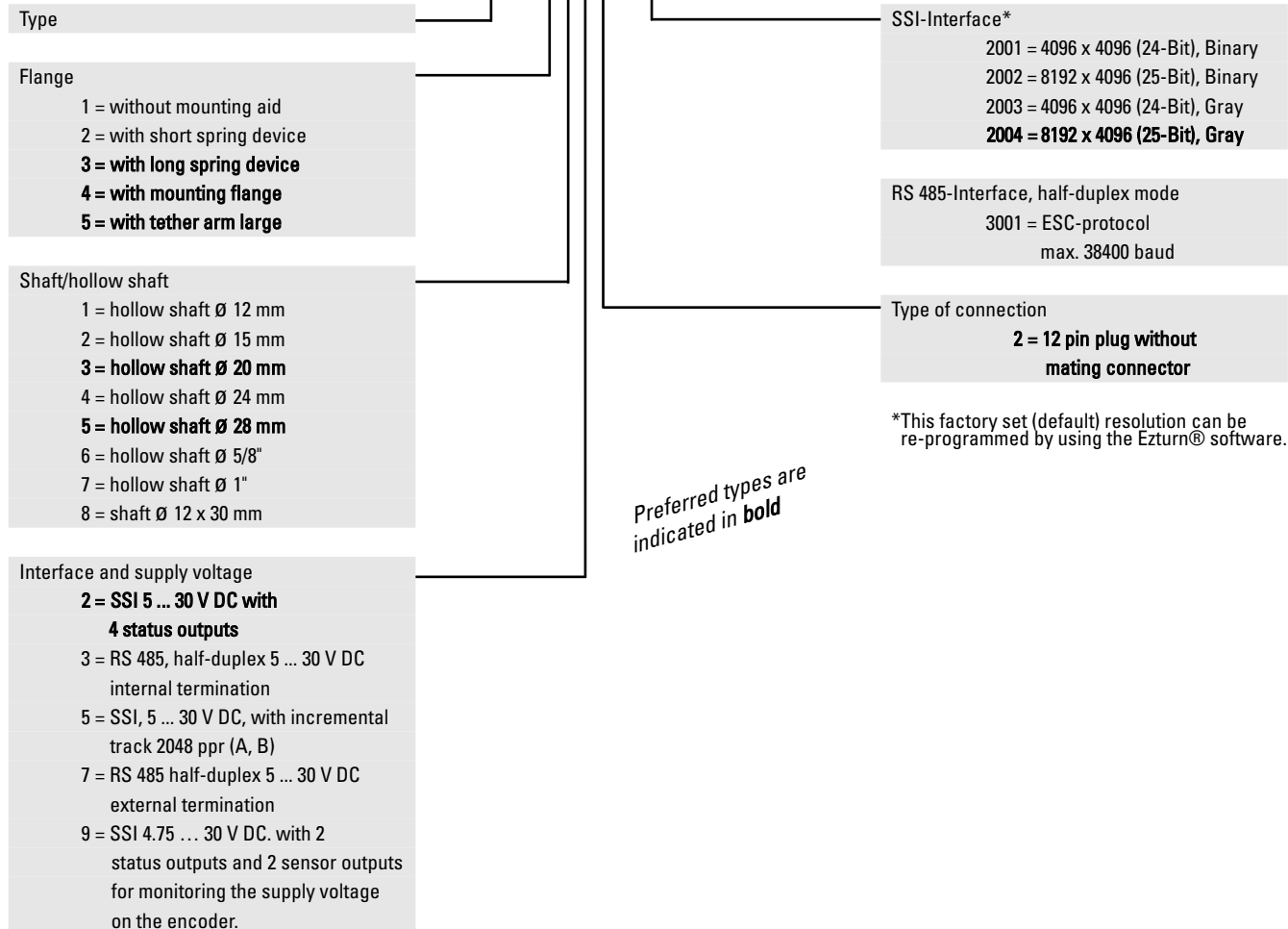

Accessories:

Mounting kit

Offers a wide variety of mounting options.

Complete kit

Order No. 8.0010.4A00.0000

The set includes the following individual items, which may also be ordered separately.

- 1 x parallel pin, long with fixing thread
- 1 x spring element, long
- 1 x spring element, short
- 2 x screws M2.5
- Screw M4 x 10
- Mounting flange
- Washer

For detailed drawings and further information, see Accessories section.

Flexible mounting flange, large

Includes:

- Flexed spring element
- 3 mounting screws

Order No. 8.0010.4E00.000

Accessories:

Corresponding mating connector to connection type 2

Order code 8.0000.5012.0000

Programming kit Ezturn® includes

- Interface converter
- Connection cable with the interface converter encoder – PC
- 90-250 V AC power supply
- CD-ROM with Ezturn® software



Order code 8.0010.9000.0004