

### Heavy duty Type 9000 / 9000 stainless steel



- Highly flexible, chemical resistant PUR cable (stands up to constant flexing at -20 °C ... +70 °C)
- Temperature and ageing compensation
- Large temperature range
- Short-circuit proof outputs

#### Type heavy duty:

- Designed for heavy duty
  - Sealed connector
- Applications: steel industry, forestry, road construction and wood industry

#### Type stainless steel:

- Stainless steel housing and shaft
  - Precision graduation at high resolution
- Applications: Food- and pharmaceutical industry, automatic packaging machines, bottling plants, chemical process technology

#### Mechanical characteristics:

Speed:	max. 6000 min <sup>-1</sup>
Rotor moment of inertia:	approx. 15 x 10 <sup>-6</sup> kgm <sup>2</sup>
Starting torque:	< 0.05 Nm
Radial load capacity of shaft*:	140 N
Axial load capacity of shaft*:	70 N
Weight:	approx. 1.2 kg stainless steel: 2.8 kg

Protection acc. to EN 60 529:	IP 66
Working temperature:	-20° C ... +85 °C <sup>1)2)</sup>
Shaft:	stainless steel
Shock resistance acc. to DIN-IEC 68-2-27	1000 m/s <sup>2</sup> , 6 ms
Vibration resistance acc. to DIN-IEC 68-2-6:	100 m/s <sup>2</sup> , 10...2000 Hz

1) 80 °C with cable  
2) Non-condensing

#### Electrical characteristics:

Output circuit:	RS 422 (TTL-compatible)	Push-pull
Supply voltage:	5 V (±5 %) or 10 ... 30 V DC	10 ... 30 V DC
Power consumption (no load) without inverted signal:	-	typ. 55 mA / max. 125 mA
Power consumption (no load) with inverted signals:	typ. 40 mA / max. 90 mA	typ. 80 mA / max. 150 mA
Permissible load/channel:	max. ±20 mA	max. ±30 mA
Pulse frequency:	max. 300 kHz	max. 300 kHz
Signal level high:	min. 2.5 V	min. U <sub>B</sub> -2.5 V
Signal level low:	max. 0.5 V	max. 2.0 V
Rise time t <sub>r</sub>	max. 200 ns	max. 1 μs
Fall time t <sub>f</sub>	max. 200 ns	max. 1 μs
Short circuit proof outputs: <sup>1)</sup>	yes <sup>2)</sup>	yes
Reverse connection protection at U <sub>B</sub> :	5 V: no, 10 ... 30 V: yes	yes

Conforms to CE requirements acc. to EN 61000-6-2, EN 61000-6-4 and EN 61000-6-3  
RoHS compliant acc. to EU guideline 2002/95/EG

1) If supply voltage correctly applied  
2) Only one channel allowed to be shorted-out:  
(If U<sub>B</sub>=5 V, short-circuit to channel, 0 V, or +U<sub>B</sub> is permitted)  
(If U<sub>B</sub>=5-30 V, short-circuit to channel or 0 V is permitted)

#### Terminal assignment

Signal:	0V	0V Sensor <sup>2)</sup>	+U <sub>B</sub>	+U <sub>B</sub> Sensor <sup>2)</sup>	A	$\bar{A}$	B	$\bar{B}$	0	$\bar{0}$	Shield
Colour:	WH 0,5 mm <sup>2</sup>	WH	BN 0,5 mm <sup>2</sup>	BN	GN	YE	GY	PK	BU	RD	

1) PH = Shield is attached to connector housing  
2) Sensor cables are connected to the supply voltage internally if long feeder cables are involved they can be used to adjust or control the voltage at the encoder

- If sensor cables are not in use, they have to be isolated or 0 V Sensor has to be connected to 0 V and U<sub>B</sub>Sensor has to be connected to U<sub>B</sub>

- Using RS 422 outputs and long cable distances, a wave impedance has to be applied at each cable end.

Isolate unused outputs before initial startup.

### Heavy duty Type 9000 / 9000 stainless steel

#### Dimensions:

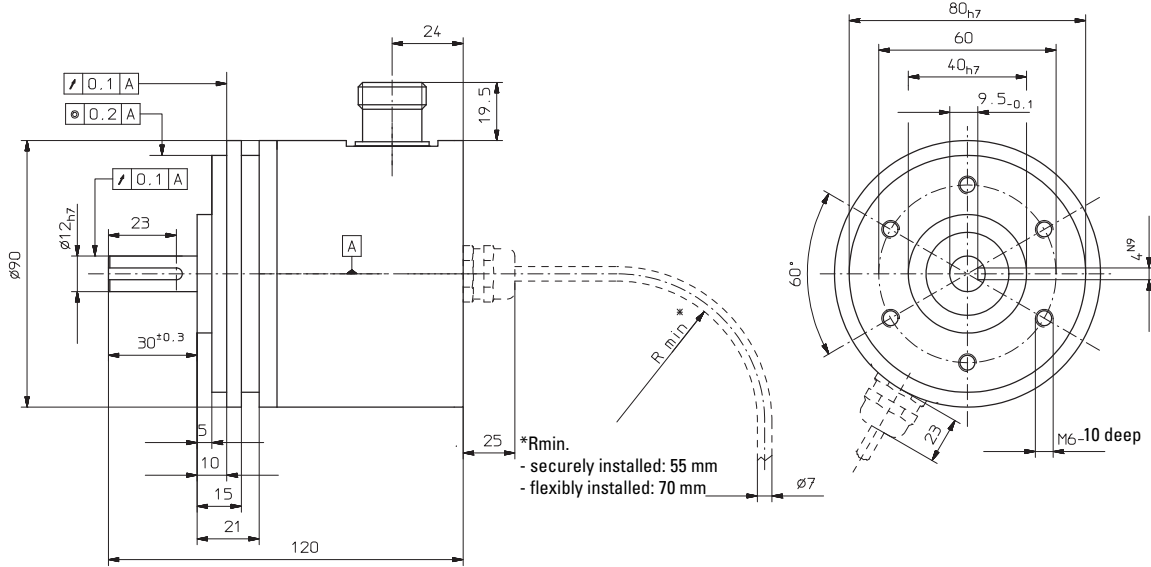

#### Top view of mating side, male contact base:

12 pin plug

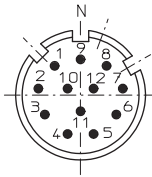

#### Order code:

**8.9000.11X1.XXXX.XXXX**

Type	Version
Output circuit and voltage display	0000 = Standard 5007 = Stainless steel version
<b>4 = RS 422 (with inverted signal)</b> <b>5 V supply voltage</b>	Pulse rate
5 = RS 422 (with inverted signal) 10 ... 30 V supply voltage	50, 500, 1000, 1024, 2000, 2048, 2500, 3000, 4096, 5000 (e.g. 250 pulses=> 0250) Other pulse rates on request
<b>6 = Push-pull (with inverted signal)</b> <b>10 .. 30 V supply voltage</b>	Type of connection
7 = Push-pull (without inverted signal) 10 ... 30 V supply voltage	1 = Cable axial (1 m PUR-cable) <b>2* = Cable radial (1 m PUR-cable)</b> 3* = axial 12 pin plug axial without mating connector <b>5* = radial 12 pin plug without mating connector</b>

#### Accessories:

Cables and connectors, also pre-assembled, can be found in the chapter Connection Technology

Mounting attachments and couplings can be found in the chapter Accessories

*Preferred types are indicated in bold*

\*not with stainless steel version

#### Accessories:

Corresponding mating connector to connection type of 3 or 5  
Order No. 8.0000.5012.0000