

Absolute Encoders

Multiturn	Sendix absolute	7063 (Shaft) with ATEX approval	SSI
------------------	------------------------	--	------------



The Sendix 7063 absolute multiturn encoders offer Ex protection in a compact 70 millimetre housing.

These shock and vibration-resistant encoders operate flexibly with a resolution of up to 29 bits; they are also available as singleturn encoders.

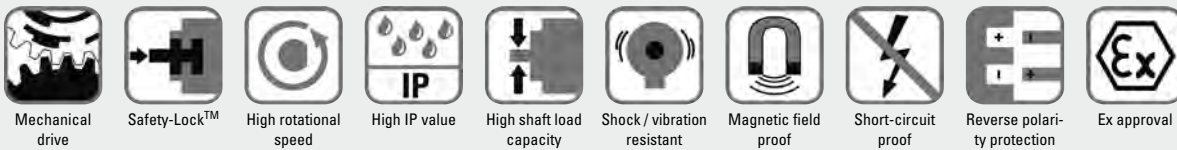

Safe

- “Flameproof-enclosure” version: approved for zone 1, 2 and 21, 22
- Zone 1, 2 and 21, 22:
 II 2G Ex d IIC T6 and II 2D Ex tD A21 IP6X T85°C
- Can be operated in marine environments – housing and flange out of seawater-resistant aluminium
- Remains sealed even in harsh everyday use and ensures highest safety against field breakdowns. IP 67 protection

Compact

- Can be used even when space is tight
- Installation depth only 145 mm, diameter 70 mm
- Compact cable outlet

Order code 8.7063 . 1 X 2 X . XX 2 1 . XXXX
Shaft version Type ① ② ③ ④ ⑤ ⑥ ⑦ ⑧ ⑨

- ① **Flange**
1 = Clamping-synchronous flange, ø 70, IP 67
- ② **Shaft (ø x L)**
1 = Shaft 12 mm x 25 mm with keyway for 4 x 4 mm key
 2 = Shaft 10 mm x 20 mm
- ③ **Output circuit / Supply voltage**
2 = SSI, 10 ... 30 V DC
- ④ **Type of connection**
1 = Cable axial (2m PVC cable)
 A = Cable axial (length > 2 m)
 (preferred lengths, see ⑨, 0100 = 10 m)

- ⑤ **Code**
 B = SSI, Binary
G = SSI, Gray
- ⑥ **Resolution ¹⁾**
 A = 10 bit ST + 12 bit MT
 1 = 11 bit ST + 12 bit MT
 2 = 12 bit ST + 12 bit MT
3 = 13 bit ST + 12 bit MT
 4 = 14 bit ST + 12 bit MT
 7 = 17 bit ST + 12 bit MT
 MT

- ⑦ **Inputs/Outputs ¹⁾**
2 = SET, DIR input
 additional status output
- ⑧ **Options**
1 = no option
- ⑨ **Cable length in dm**
0050 = 5 m
0100 = 10 m
0150 = 15 m

Preferred types are underlined

¹⁾ Resolution, preset value and counting direction factory-programmable

Absolute Encoders

Multiturn	Sendix absolute	7063 (Shaft) with ATEX approval	SSI
------------------	------------------------	--	------------

Explosion protection	
EC type-examination certificate	PTB09 ATEX 1106 X
Category (gas)	II 2G Ex d IIC T6
Category (dust)	II 2D Ex tD A21 IP6X T85°C
Directive 94/9 EC	EN 60079-0; DIN EN 60079-1 EN 61241-0; DIN EN 61241-1

Mechanical characteristics	
Max. speed	6 000 min ⁻¹ continuous
Starting torque	< 0,05 Nm
Weight moment of inertia	4,0 x 10 ⁻⁶ kgm ²
Shaft load capacity	radial 80 N axial 40 N
Weight	approx. 0,6 kg
Protection acc. to EN 60 529	IP 67
Working temperature range	-40°C ... +60°C
Materials	shaft stainless steel flange seawater-resistant Al, type AISiMgMn (EN AW-6082) (optional: stainless steel) housing seawater-resistant Al, type AISiMgMn (EN AW-6082) (optional: stainless steel) cable PVC
Shock resistance acc. to DIN-IEC 68-2-27	> 2500 m/s ² , 6 ms
Vibration resistance acc. to DIN-IEC 68-2-6	> 100 m/s ² , 55 ... 2000 Hz

General electrical characteristics	
Supply voltage	10 ... 30 V DC
Current consumption (w/o output load)	24 V DC max. 25 mA
Reverse polarity protection for power supply (Ub)	yes
CE compliant acc. to	EN 61000-6-2, EN 61000-6-4 and EN 61000-6-3
RoHS compliant acc. to	EU guideline 2002/95/EG

SSI interface	
Output driver	RS 485 Transceiver type
Permissible load/channel	max. 20 mA
Signal level	high typ 3,8 V low for I _{Last} = 20 mA typ 1,3 V
Short-circuit proof outputs	yes ¹⁾
Singleturn resolution	10...14 bit and 17 bit ²⁾
Number of revolutions	4096 (12 bit)
Code	Binär or Gray
SSI clock rate	< 14 bit: 50 kHz ... 2 MHz
Monoflop time	< 15 µs ²⁾
Note: if clock starts cycling within monoflop time a second data transfer starts with the same data. If clock starts cycling after monoflop time, the data transfer starts with updated values. The update rate depends on clock speed, data length and monoflop time.	
Time jitter	up to 14 bit < 1 µ for 15 ... 17 bit < 4 µs
Status and Parity bit	upon request

1) Short-circuit with 0V or output, only one channel at a time, supply voltage correctly applied
2) Other options upon request

SET input	
Input	high active
Input type	Comparator
Signal level	high min. 60 % of V ₊ max: V ₊ low max. 25 % of V ₊ (V ₊ = supply voltage)
Input current	< 0,5 mA
Min. pulse duration (SET)	10 ms
Timeout after SET signal	14 ms
Response time (DIR input)	1 ms
The encoder can be set to zero at any position by means of a High signal on the SET input. Other preset values can be factory-programmed. The SET input has a signal delay time of approximately 1 ms. Once the SET function has been triggered, the encoder requires an internal processing time of approximately 15 ms before the new position data can be read.	

DIR input	
A High signal switches the direction of rotation from the default CW to CCW. The reverse function can also be factory-programmed.	
If DIR is reversed when the device is already switched on, this will be interpreted as an error. The status output switches to Low.	

Status output	
Output driver	Open collector internal pull-up resistor 22 kohm
Permissible load	20 mA
Signal level	high +V low < 1 V
Active at	low
The status output serves to display various alarm or error messages. The status output is high (Open Collector with internal pull-up 22k) in normal operation.	

Power-on delay	
After Power-On, the device requires a time of approximately 150 ms before valid data can be read.	

Absolute Encoders

Multiturn	Sendix absolute	7063 (Shaft) with ATEX approval	SSI
------------------	------------------------	--	------------

Terminal assignment

for output circuit 1 or 2

Signal	GND	+V	+C	-C	+D	-D	SET	DIR	Stat	PE	PE
Cable marking	1	2	3	4	5	6	7	8	9	yellow/green	Shield

+V: Encoder power supply +V DC

GND: Encoder Ground GND (0V)

+C, -C: Clock signal

+D, -D: Data signal

SET: Set input. The current position becomes defined as position zero.

DIR: Direction input. If this input is active, output values are decreasing when shaft is turned clockwise

Stat: Status output

PE: Protective earth

Dimensions

Shaft type 1

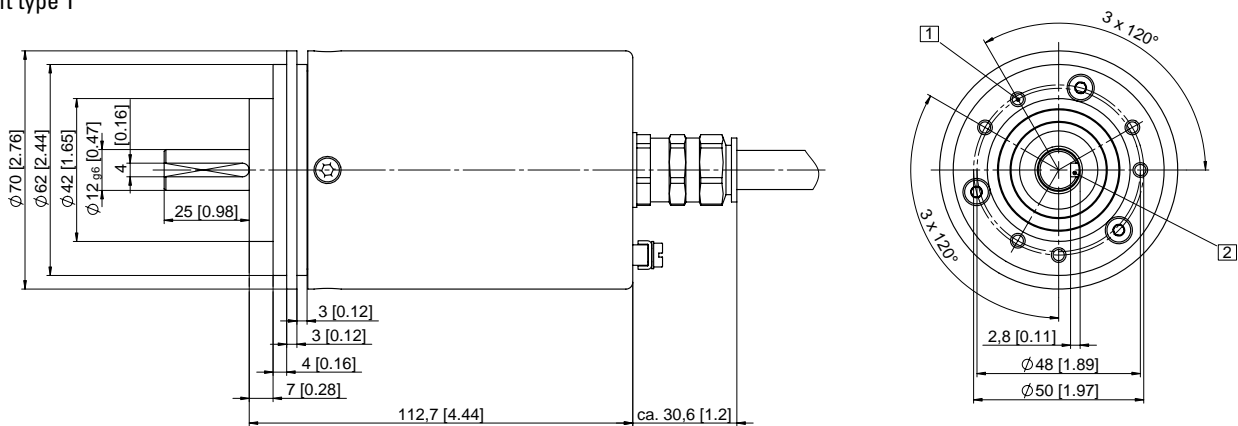

Shaft type 2

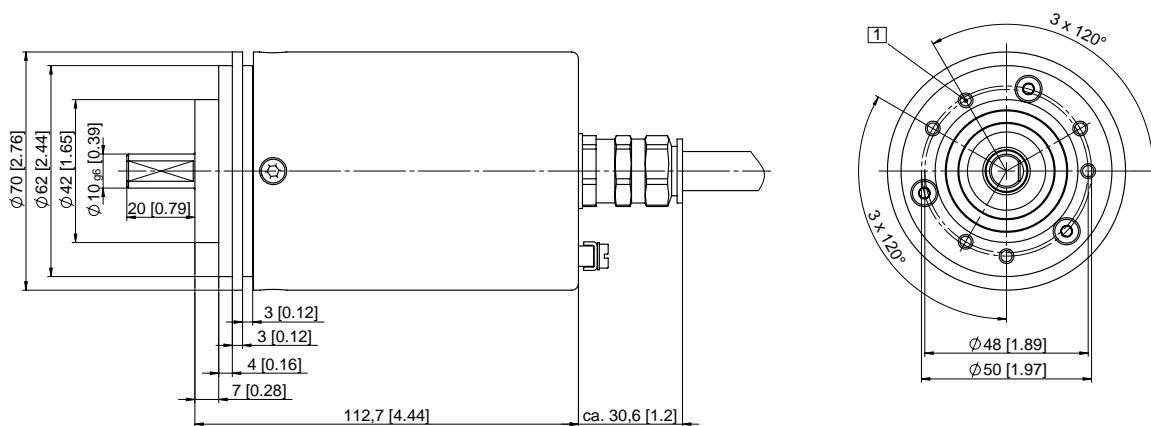

1 6 x M4, 10 [0,39] deep

2 Keyway for DIN6885-A-4x4x25 key