

Rotary Measuring Technology

Absolute encoders, Singleturn

Type 7031 with ATEX approval



Temperature



Shock/vibration resistant



Short-circuit proof



Reverse polarity protection

One type for every situation:

- **Version "flameproof-enclosure"**: approval zones 1, 2 and 21, 22
- **Zones 1, 2 and 21, 22:**
 - ⊕ II 2G Ex d II C T6 and
 - ⊕ II 2D Ex tD A21 IP6x T85°C
- **High resolution:**
max. 5000 ppr.
- **Choice of construction:**
Through hollow shaft or solid shaft up to max. \varnothing 12 mm.



Compact:

- **Can be used even where space is tight:** installation depth only 94 mm, minimal clearance required - thanks to through hollow shaft

Safe:

- **Easy start-up**, short-circuit proof outputs, reverse polarity protection, over-voltage protection
- **No malfunction if voltage is too high**

Mechanical characteristics:

Speed:	max. 6000 min ⁻¹
Rotor moment of inertia:	approx. 8×10^{-6} kgm ²
Starting torque:	< 0.05 Nm
Radial load capacity of shaft*:	80 N
Axial load capacity of shaft*:	40 N
Weight:	approx. 0.9 kg
Protection acc. to EN 60 529:	IP 65
EX approval for hazardous areas:	optional zone 2 and 22
Working temperature:	-20° C ... +60 °C ¹⁾
Shaft:	stainless steel
Shock resistance acc. to DIN-IEC 68-2-27	1000 m/s ² , 6 ms
Vibration resistance acc. to DIN-IEC 68-2-6:	100 m/s ² , 10...2000 Hz

*) Shaft version: end of the shaft ¹⁾ Non-condensing

Type 7031 with ATEX approval

Electrical characteristics:

Interface type:	Synchronous Serial (SSI)	Synchronous Serial (SSI)	Parallel	Parallel
Supply voltage (U_B):	5 V DC ($\pm 5\%$)	10 ... 30 V DC	5 V DC ($\pm 5\%$)	10 ... 30 V DC
Output driver:	RS 485	RS 485	Push-pull	Push-pull
Current consumption typ. (no load) max.:	89 mA 138 mA	89 mA 138 mA	109 mA 169 mA	109 mA 169 mA
Permissible load/channel max.:	+/- 20 mA	max. +/- 20 mA	max. +/- 10 mA	max. +/- 10 mA
Word change frequency	max. 15.000/s	max. 15.000/s	40.000/s	40.000/s
SSI pulse rate min./max.:	100 kHz/500 kHz	100 kHz/500 kHz	–	–
Signal level high:	type. 3.8 V	typ. 3.8 V	min. 3.4 V	min. $U_B - 2.8 V$
Signal level low				
	($I_{Load} = 20 mA$):	typ. 1.3 V	typ. 1.3 V	–
	($I_{Load} = 10 mA$):	–	–	max. 1.5 V
	($I_{Load} = 1 mA$):	–	–	max. 0.3 V
Rise time t_r (without cable):	max. 100 ns	max. 100 ns	max. 0.2 μs	max. 1 μs
Fall time t_f (without cable):	max. 100 ns	max. 100 ns	max. 0.2 μs	max. 1 μs
Short circuit proof outputs: ¹⁾	yes	yes ²⁾	yes	yes
Reverse connection protection at U_B :	no	yes	no	yes
Conforms to CE requirements acc. to EN 61000-6-2, EN 61000-6-4 and EN 61000-6-3				

1) If supply voltage correctly applied

2) Only one channel allowed to be shorted-out:

(If $U_B=5 V$, short-circuit to channel, 0 V, or + U_B is permitted)

(If $U_B=5-30 V$, short-circuit to channel or 0 V is permitted)

Electrical characteristics, current interface 4 ... 20 mA:

Sensor part		
Interface type:	4 ... 20 mA	4 ... 20 mA
Supply voltage (U_B):	10 ... 30 V DC	5 V DC
Current consumption typ.:	70 mA	70 mA
(no load) max.:	84 mA	84 mA
Word change frequency	max. 15.000/s	max. 15.000/s

Current loop

Supply voltage:	10 ... 30 V DC	10 ... 30 V DC
Analogue signal	4 ... 20 mA	4 ... 20 mA
Max. input resistance of the input circuit:	200 Ω	200 Ω
Measuring range:	0 ... 360 °	0 ... 360 °
Max. failure (25 °C):	0.2 °	0.2 °
Resolution	13 Bit	13 Bit
Building up time:	max. 2 ms	max. 2 ms
Temperature coefficient 0,1°/10 K		0,1°/10 K
Current if detector error:	$\leq 3 mA$	$\leq 3 mA$

Sensor and current loop are galvanically isolated

Conforms to CE requirements acc. to EN 61000-6-2, EN 61000-6-4 and EN 61000-6-3

Note:

All standards for installation of electrical systems in hazardous environments have to be observed.

Manipulations (opening, mechanical treatment etc.) will cause the loss of the EX- license, warranty claims will not be accepted and the installer will be responsible for any consequential damages.

Rotary Measuring Technology

Absolute encoders, Singleturn



Type 7031 with ATEX approval

Terminal assignment (Current interface 4 ... 20 mA):

Sig.	0V	+UB	I+	I-	ST	VR		
Col.:	WH	BN	GN	YE	GY	PK		PH

- +I: Input of the current loop
 - I: Output of the current loop
 - ST: SET input. The output current is set to 4 mA.
 - VR: Up/down input. As long as this input is active, decreasing current values are transmitted when shaft turning clockwise.
 - PH: Plug housing
- Isolate unused outputs before initial start-up.

Dimensions hollow shaft version:

Synchronous flange with hollow shaft $\varnothing 12$

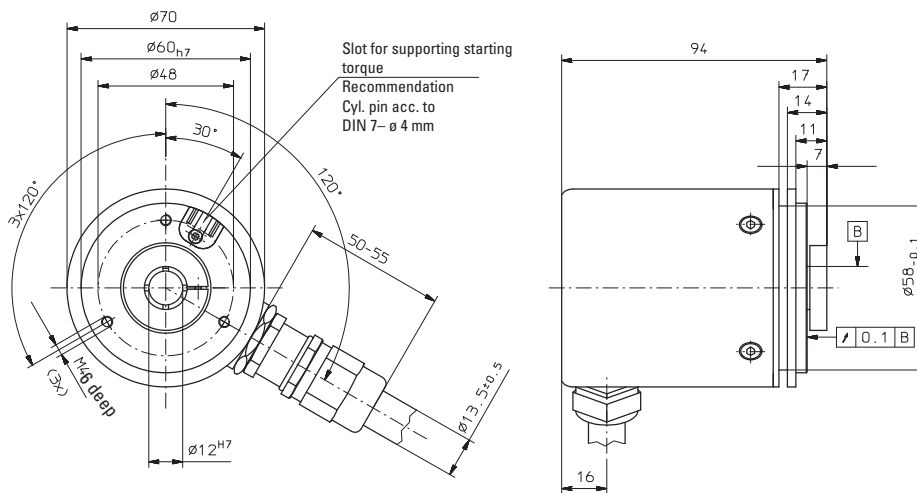

Dimensions shaft version:

Clamping flange with shaft $\varnothing 12$

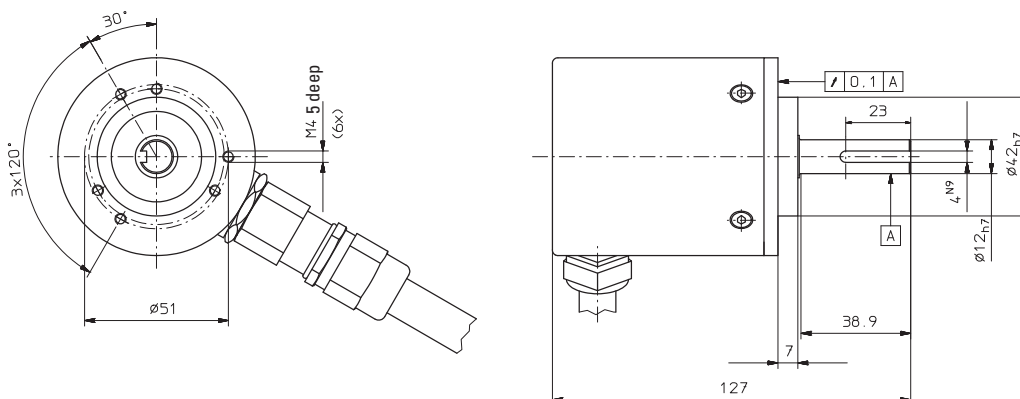

Type 7031 with ATEX approval

Dimensions shaft version:

Clamping flange with flange adapter and shaft $\varnothing 12$

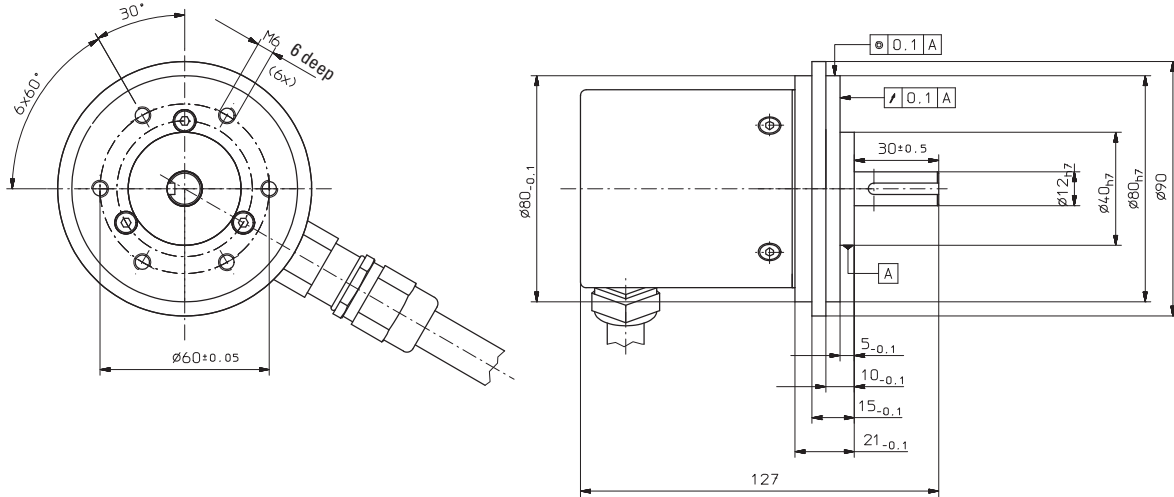

Code type and division

Interface and supply voltage, version 3 or 4:

Division	Order code	Order code	Order code
	Gray/Gray-Excess	Binary	BCD
250	E02	B02	D02
360	E03	B03	D03
500	E05	B05	D05
720	E07	B07	D07
900	E09	B09	D09
1000	E01	B01	D01
1024 (10 Bit)	G10	B10	D10
1250	E12	BA2	DA2
1440	E14	BA1	DA1
1800	E18	B18	D18
2000	E20	B20	D20
2500	E25	B25	
2880	E28	B28	
3600	E36	B36	
4000	E40	B40	
4096 (12 Bit)	G12	B12	
5000	E50	B50	
7200	E72	B72	
8192 (13 Bit)	G13	B13	
16384 (14 Bit)	G14	B14	

Preferred divisions are indicated in bold

Code type and division for encoder with SSI-output

Interface and supply voltage, version 1 or 2:

Division	Order code	Order code
	Gray	Binary
1024 (10 Bit)	G10	B10
4096 (12 Bit)	G12	B12
8192 (13 Bit)	G13	B13
16384 (14 Bit)	G14	B14

Code type and division for encoder with analogue output

Interface and supply voltage, version 7 or 8:

8192 (13 Bit)	G13
---------------	-----

Type 7031 with ATEX approval

Order code:

8.7031.XXXX.XXXX

