

Rotary Measuring Technology

Incremental shaft/hollow shaft encoder

Type 7030 with ATEX approval



Temperature



Shock/vibration resistant



Short-circuit proof



Reverse polarity protection

One type for every situation:

- **Version "flameproof-enclosure":** approval 1, 2 and 21, 22
- **Zone 1, 2 and 21, 22:**
 - ⊕ II 2G Ex d II C T6 and
 - ⊕ II 2D Ex tD A21 IP6x T85°C
- **High resolution:**
max. 5000 ppr.
- **Choice of construction:**
Through hollow shaft or solid shaft up to max. ø 12 mm.



Compact:

- **Can be used even where space is tight:**
installation depth only 94 mm, minimal clearance required - thanks to through hollow shaft

Safe:

- **Easy start-up,** short-circuit proof outputs, reverse polarity protection, over-voltage protection
- **No malfunction if voltage is too high**

Mechanical characteristics:

Speed:	max. 6000 min ⁻¹
Rotor moment of inertia:	approx. 15 x 10 ⁻⁶ kgm ²
Starting torque:	< 0.05 Nm
Radial load capacity of shaft:	80 N
Axial load capacity of shaft:	40 N
Weight:	approx. 1.2 kg
Protection acc. to EN 60 529:	IP 65
EX approval for hazardous areas:	ATEX, Explosion proof zone 1 and 21 ⊕ II 2G Ex d II C T6 and ⊕ II 2D Ex tD A21 IP6x T85°C
Working temperature:	-20° C ... +60 °C ¹⁾
Shaft:	stainless steel
Shock resistance acc. to DIN-IEC 68-2-27	1000 m/s ² . 6 ms
Vibration resistance acc. to DIN-IEC 68-2-6:	100 m/s ² , 10 ... 2000 Hz

¹⁾ Non-condensing

Please note!

- All standards for installation of electrical systems in hazardous environments have to be observed.
- Manipulations (opening, mechanical treatment etc.) will cause the loss of the EX-license, warranty claims will not be accepted and the installer will be responsible for any consequential damages.

Rotary Measuring Technology

Incremental shaft/hollow shaft encoder



Type 7030 with ATEX approval

Electrical characteristics:

Output circuit:	RS 422 (TTL-compatible)	Push-pull
Supply voltage:	5 V ($\pm 5\%$) or 10 ... 30 V DC	10 ... 30 V DC
Power consumption (no load) without inverted signal:	-	typ. 55 mA / max. 125 mA
Power consumption (no load) with inverted signals:	typ. 70 mA / max. 90 mA	typ. 80 mA / max. 150 mA
Permissible load/channel:	max. ± 20 mA	max. ± 30 mA
Pulse frequency:	max. 300 kHz	max. 300 kHz
Signal level high:	min. 2.5 V	min. $U_B - 2.5$ V
Signal level low:	max. 0.5 V	max. 2.0 V
Rise time t_r	max. 200 ns	max. 1 μ s
Fall time t_f	max. 200 ns	max. 1 μ s
Short circuit proof outputs: ¹⁾	yes ²⁾	yes
Reverse connection protection at U_B :	no	yes
Conforms to CE requirements acc. to EN 61000-6-2, EN 61000-6-4 and EN 61000-6-3		
RoHS compliant acc. to EU guideline 2002/95/EG		

1) If supply voltage correctly applied

2) Only one channel allowed to be shorted-out:

(If $U_B=5$ V, short-circuit to channel, 0 V, or $+U_B$ is permitted)
 (If $U_B=5-30$ V, short-circuit to channel or 0 V is permitted)

Terminal assignment

Signal:	0V	0V Sensor ²⁾	$+U_B$	$+U_B$ Sensor ²⁾	A	\bar{A}	B	\bar{B}	0	$\bar{0}$	Shield
Colour:	WH	GY PK	BN	RD BU	GN	YE	GY	PK	BU	RD	PH ¹⁾

¹⁾ PH = Shield is attached to connector housing

²⁾ Sensor cables are connected to the supply voltage internally if long feeder cables are involved they can be used to adjust or control the voltage at the encoder

- If sensor cables are not in use, they have to be isolated or 0 V_{Sensor} has to be connected to 0 V and $U_{B\text{Sensor}}$ has to be connected to U_B

- Using RS 422 outputs and long cable distances, a wave impedance has to be applied at each cable end.

Isolate unused outputs before initial startup.

Dimensions hollow shaft version:

8.7030.14xx

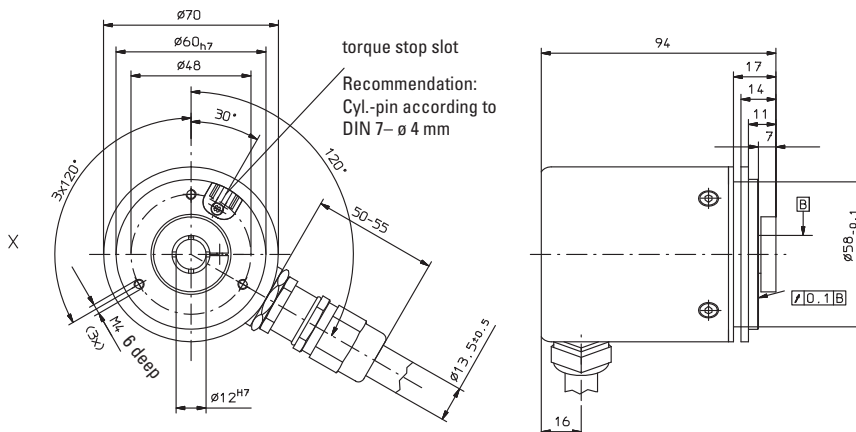

Type 7030 with ATEX approval

Dimensions shaft version:

8.7030.25xx

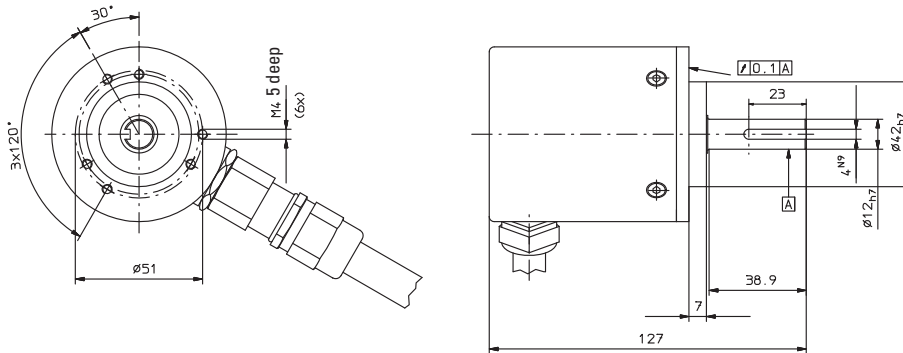

Dimensions shaft version:

8.7030.26xx

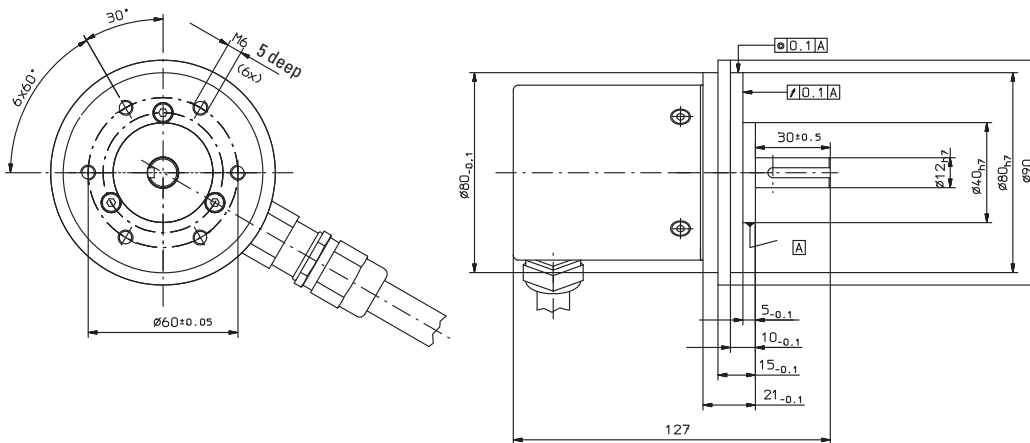

Dimensions hollow shaft version:

8.7030.27xx

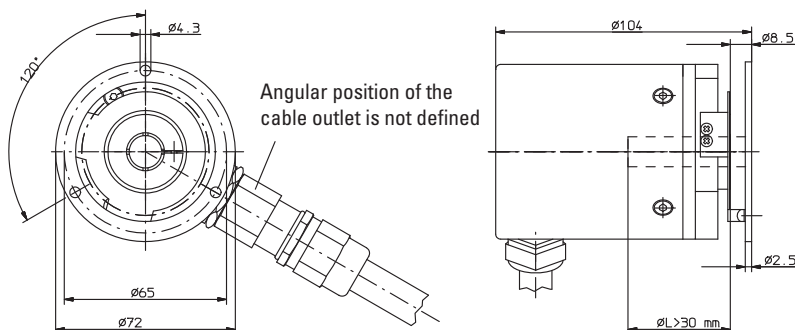

Rotary Measuring Technology

Incremental shaft/hollow shaft encoder

Type 7030 with ATEX approval

Order code:

8.7030.XXXX.XXXX

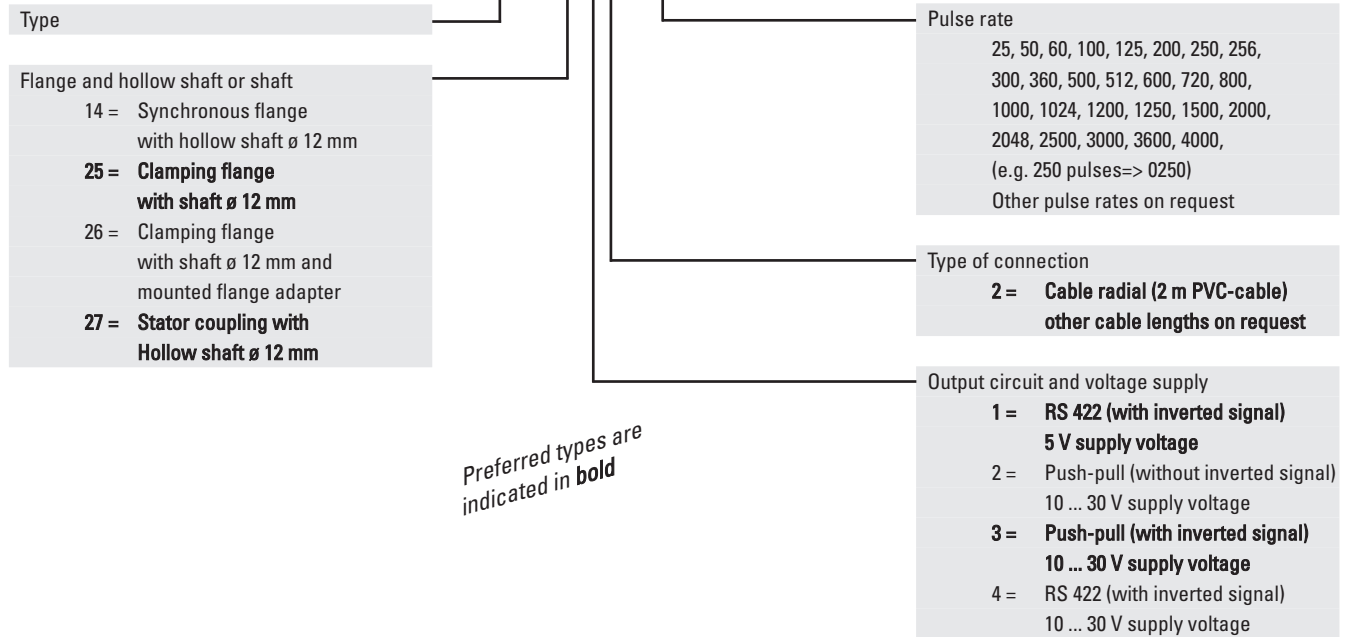

Incremental Encoders

Accessories:

Cables and connectors, also pre-assembled, can be found in the chapter Connection Technology

Mounting attachments and couplings can be found in the chapter Accessories