

Sendix absolut, Singleturn Type 5853 (Shaft) / 5873 (Hollow shaft), SSI/BiSS

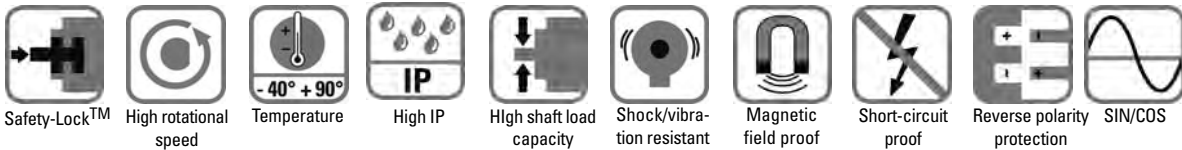

Reliable

- **Increased ability to withstand vibration and installation errors. Eliminates machine downtime and repairs.**
Sturdy "Safety-Lock™ Design" bearing structure
- **Fewer components and connection points increase the operational reliability**
Kübler OptoASIC technology with highest integration density (Chip-on-Board)
- **Remains sealed even when subjected to harsh everyday use. Thus suitable also for outside use.**
Resistant die cast housing and protection up to IP 67
- **Can be used in a wide temperature range without additional expense**
Wide temperature range (-40°C...+90°C)
- **Easy diagnostic in case of trouble**
Status indication by means of LED, sensor, voltage and temperature monitoring



Sendix® absolut

Fast

- **Can achieve particularly high accuracy in the applications**
Update rate of the whole position value above 100 kHz for a max. jitter of 1 μs (real-time)
- **Allows high productivity thanks to very short regulation cycles**
Clock rate with SSI up to 2 MHz, with BiSS up to 10 MHz
- **High-resolution feedback system achievable in real-time**
SinCos incremental outputs

Versatile

- **The suitable connection variant for every specific case**
Cable, M23 connector or M12 connector
- **Open interfaces ensure flexibility and independence**
SSI or BiSS with Sine-Cosine-Option
- **Reliable installation in a wide diversity of mounting application**
Extensive choice of proven mounting options
- **Only the functionality really needed by the user is implemented**
Status LED and Set key available as options
- **Fast and easy start-up on site**
Set key or Preset by means of a control input
- **Hollow shaft version: direct mounting also on large diameter shafts**
Through hollow shaft up to 15 mm
- also available in **seawater resistant** version, certified acc. to salt-spray test IEC 68-2-11 => 672 hours.

Mechanical characteristics:

Shaft version:

Max. speed without shaft sealing (IP 65) up to 70 °C:	12 000 min ⁻¹ , continuous 10 000 min ⁻¹
Max. speed without shaft sealing (IP 65) up to T _{max} :	8 000 min ⁻¹ , continuous 5 000 min ⁻¹
Max. speed with shaft sealing (IP 67) up to 70 °C:	11 000 min ⁻¹ , continuous 9 000 min ⁻¹
Max. speed with shaft sealing (IP 67) up to T _{max} :	8 000 min ⁻¹ , continuous 5 000 min ⁻¹

Hollow shaft version:

Max. speed without shaft sealing (IP 65) up to 70 °C:	9 000 min ⁻¹ , continuous 6 000 min ⁻¹
Max. speed without shaft sealing (IP 65) up to T _{max} :	6 000 min ⁻¹ , continuous 3 000 min ⁻¹
Max. speed with shaft sealing (IP 67) up to 70 °C:	8 000 min ⁻¹ , continuous 4 000 min ⁻¹
Max. speed with shaft sealing (IP 67) up to T _{max} :	4 000 min ⁻¹ , continuous 2 000 min ⁻¹

Starting torque without shaft sealing (IP65):	Shaft version: < 0.01 Nm Hollow shaft version: <0.03 Nm
---	--

Starting torque with shaft sealing (IP67): < 0.05 Nm

Moment of inertia:	Shaft version: 3.0 x 10 ⁻⁶ kgm ² Hollow shaft version: 6.0 x 10 ⁻⁶ kgm ²
--------------------	---

Radial load capacity of shaft: 80 N

Axial load capacity of shaft: 40 N

Weight: approx. 0.35 kg

Protection acc. to EN 60 529: housing: IP 67, shaft: IP 65, opt. IP 67

EX approval for hazardous areas: optional zone 2 and 22



Encoder with tangential cable outlet

Sendix absolut, Singleturn Type 5853 (Shaft) / 5873 (Hollow shaft), SSI/BISS

Mechanical characteristics:

Working temperature:	-40° C ... +90 °C ¹⁾
Materials:	Shaft: stainless steel, Flange: aluminum, Housing: die cast zinc, Cable: PVC
Shock resistance acc. to DIN-IEC 68-2-27:	>2500 m/s ² , 6 ms
Vibration resistance acc. to DIN-IEC 68-2-6:	>100 m/s ² , 55 ... 2000 Hz

¹⁾ Cable versions: -30 °C ... +75°C

General electrical characteristics:

Supply voltage:	5 V DC ± 5% or 10 ... 30 V DC
Current consumption (w/o output load):	5 V DC: max. 70 mA, 24 V DC: max. 20 mA
Reverse polarity protection at power supply (U _b):	Yes (only 10 ... 30 V DC)
UL certified	File 224618
Conforms to CE requirements acc. to EN 61000-6-2, EN 61000-6-4 and EN 61000-6-3	
RoHS compliant acc. to EU guideline 2002/95/EG	

General Interface characteristics:

Output driver:	RS 485 Transceiver type
Permissible load/channel:	max. ± 20 mA
Signal level high:	typ. 3.8 V
Signal level low at I _{load} = 20 mA:	typ. 1.3 V
Short circuit proof outputs:	Yes ²⁾

Interface characteristics SSI:

Singleturn resolution:	10 ... 14 bits and 17 bits ³⁾
Code:	Binary or Gray
SSI clock rate:	≤ 14 bits: 50 kHz ... 2 MHz > 15 bits: 50 kHz ... 125 kHz
Monoflop time:	≥ 15 μs ³⁾
Note:	If clock starts cycling within monoflop time a second data transfer starts with the same data, useful for data verification. If clock starts cycling after monoflop time the data transfer starts with updated values. Max. update rate is depending on clock speed, data length and monoflop-time.
Time jitter (data request to position latch):	< 1 μs up to 14 bits, 4 μs at 15 ... 17 bits
Status and Parity bit:	optional on request

Interface characteristics BISS:

Singleturn resolution:	10 ... 14 bits and 17 bits, customer programmable ³⁾
Code:	Binary
Interfaces:	RS 485
Clock rate:	up to 10 MHz
Max. update rate:	< 10 μs, depending on clock speed and data length
Time jitter (data request to position latch):	≤ 1 μs
Note:	- Bidirectional, programmable parameters are: resolution, code, direction, alarms and warnings - Multicycle data output, e.g. for temperature - CRC data verification

²⁾ Short circuit to 0V or to output, one channel at a time, supply voltage correctly applied

³⁾ Other options upon request

SET (zero or defined value) and DIRrection (CW/CCW) control inputs

Input characteristics:	High active
Receiver type:	Comparator
Signal level high:	min. 60 % of V ₊ (Supply voltage), max: V ₊
Signal level low:	max. 25% of V ₊ (Supply voltage)
Input current:	≤ 0.5 mA
Min. pulse duration (SET):	10 ms
Timeout after SET input:	14 ms
Reaction Time (DIR input):	1 ms

The encoder can be set to zero at any position by means of a HIGH signal on the SET input or by pressing the optional SET key. Other preset values can be factory-programmed. The SET input has a signal delay time of approx. 1 ms. Once the SET function has been triggered, the encoder requires an internal processing time of approx. 15 ms before the new position data can be read. During this time the LED is ON and the status output is at LOW.

Status output and LED

Output driver:	Open collector, internal pull up resistor 22 kOhm
Permissible load:	-20 mA
Signal level high:	+V
Signal level low:	< 1 V
Active at:	Low

The optional LED (red) and the status output serve to display various alarm or error messages. In normal operation the LED is OFF and the status output is HIGH (open-collector with int. pull-up 22k).

If the LED is ON (status output LOW) this indicates:

- Sensor error, singleturn or multiturn (soiling, glass breakage etc.)
- LED error, failure or ageing
- Over- or under-temperature
- Undervoltage

In the SSI mode, the fault indication can only be reset by switching off the power-supply to the device.

DIR input

A HIGH signal switches the direction of rotation from the default CW to CCW. This inverted function can also be factory-programmed. If DIR is changed when the device is already switched on, then this will be interpreted as an error. The LED will come ON and the status output will switch to LOW.

Option incremental output (A/B), 2048 ppr

	Sin/Cos	RS422 (TTL compatible)
-3dB frequency:	400 kHz	400 kHz
Signal level:	1 V _{pp} (± 20%)	high: min. 2.5 V low: max. 0.5 V
Short circuit proof:	Yes ²⁾	Yes ²⁾

Power-on delay

After Power-ON the device requires a time of approx. 150 ms before valid data can be read.

Sendix absolut, Singleturn Type 5853 (Shaft) / 5873 (Hollow shaft), SSI/BiSS

Terminal assignment:

for output circuit 1 or 2 and type of connection 1, 2, 3 or 4 (2 control inputs, 1 status output)

Signal:	GND	+V	+C	-C	+D	-D	SET	DIR	Stat	N/C	N/C	N/C	PE
Cable colour:	WH	BN	GN	YE	GY	PK	BU	RD	BK	-	-	-	Shield
M23 PIN out:	1	2	3	4	5	6	7	8	9	10	11	12	PH

for output circuit 5 and type of connection 1, 2, 3 or 4 (2 control inputs, 1 status output, sensor outputs for voltage)

Signal:	GND	+V	+C	-C	+D	-D	SET	DIR	Stat	N/C	0 V Sens	+Ub Sens	PE
Cable colour:	WH	BN	GN	YE	GY	PK	BU	RD	BK	-	GY-PK	RD-BU	Shield
M23 PIN out:	1	2	3	4	5	6	7	8	9	10	11	12	PH

for output circuit 3, 4, 7 or 8 and type of connection 1, 2, 3 or 4 (2 control inputs, incremental track RS422 or sine/cosine)

Signal:	GND	+V	+C	-C	+D	-D	SET	DIR	A	A inv	B	Binv	PE
Cable colour:	WH	BN	GN	YE	GY	PK	BU	RD	BK	VT	GY-PK	RD-BU	Shield
M23 PIN out:	1	2	3	4	5	6	7	8	9	10	11	12	PH

for output circuit 6 or 9 and type of connection 1, 2, 3 or 4 (Sine/cosine or incremental track, voltage sense outputs)

Signal:	GND	+V	+C	-C	+D	-D	A	A inv	B	B inv	0V Sens	+Ub Sens	PE
Cable colour:	WH	BN	GN	YE	GY	PK	BU	RD	BK	VT	GY-PK	RD-BU	Shield
M23 PIN out:	1	2	3	4	5	6	7	8	9	10	11	12	PH

for output circuit 1 or 2 and type of connection 5 or 6 (2 control inputs)

Signal:	GND	+V	+C	-C	+D	-D	SET	DIR	Shield/PE
M12 PIN out:	1	2	3	4	5	6	7	8	PH

- +V: Encoder Power Supply +V DC
- GND: Encoder Power Supply Ground (0V)
- +C, -C: Clock signal
- +D, -D: Data signal
- SET: Set input. The current position becomes defined as zero position
- DIR: Direction input: If this input is active, output values are decreasing when shaft is turned clockwise.
- Stat: Status output
- PE: Protective earth
- PH: Plug housing (shield)
- A, Ainv: Sine output (incremental)
- B, Binv: Cosine output (incremental)



SET key:
For quick, simple on-site start-up

LED:
Status indication for sensor, voltage and temperature monitoring.

Top view of mating side, male contact base:

Type	8 pin M12 connector	12 pin M23 connector
View		
Corresponding mating connector:	05.CMB-8181-0	8.0000.5012.0000



SET key:
For quick, simple on-site start-up

LED:
Status indication for sensor, voltage and temperature monitoring.

Sendix absolut, Singleturn Type 5853 (Shaft) / 5873 (Hollow shaft), SSI/BiSS

Dimensions shaft version:

Synchro flange

ø 58 mm, M12-, M23 Connector, cable versions
Flange type 2 and 4 (Drawing with M12 connector)

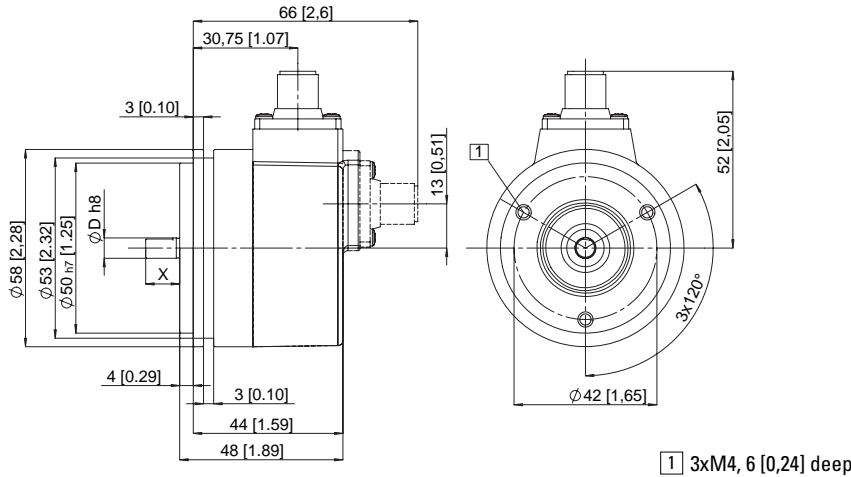

Clamping flange

ø 58 mm, M12, M23 connector, cable versions
Flange type 1 and 3 (Drawing with M23 connector)

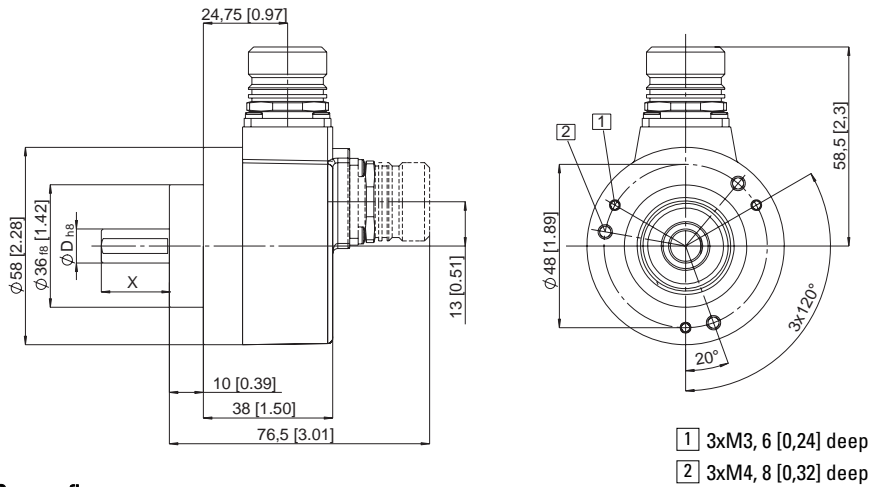

Square flange

63.5 mm □, M12, M23 connector, cable versions
Flange type 5 and 7 (Drawing with cable version)

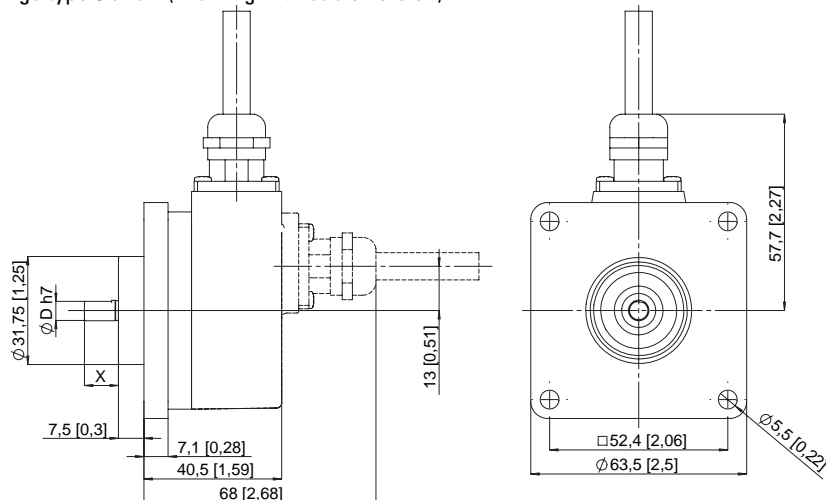

Sendix absolut, Singleturn Type 5853 (Shaft) / 5873 (Hollow shaft), SSI/BiSS

Order code shaft version:

8 . 5 8 5 3 . X X X X . X X X X

10 by 10

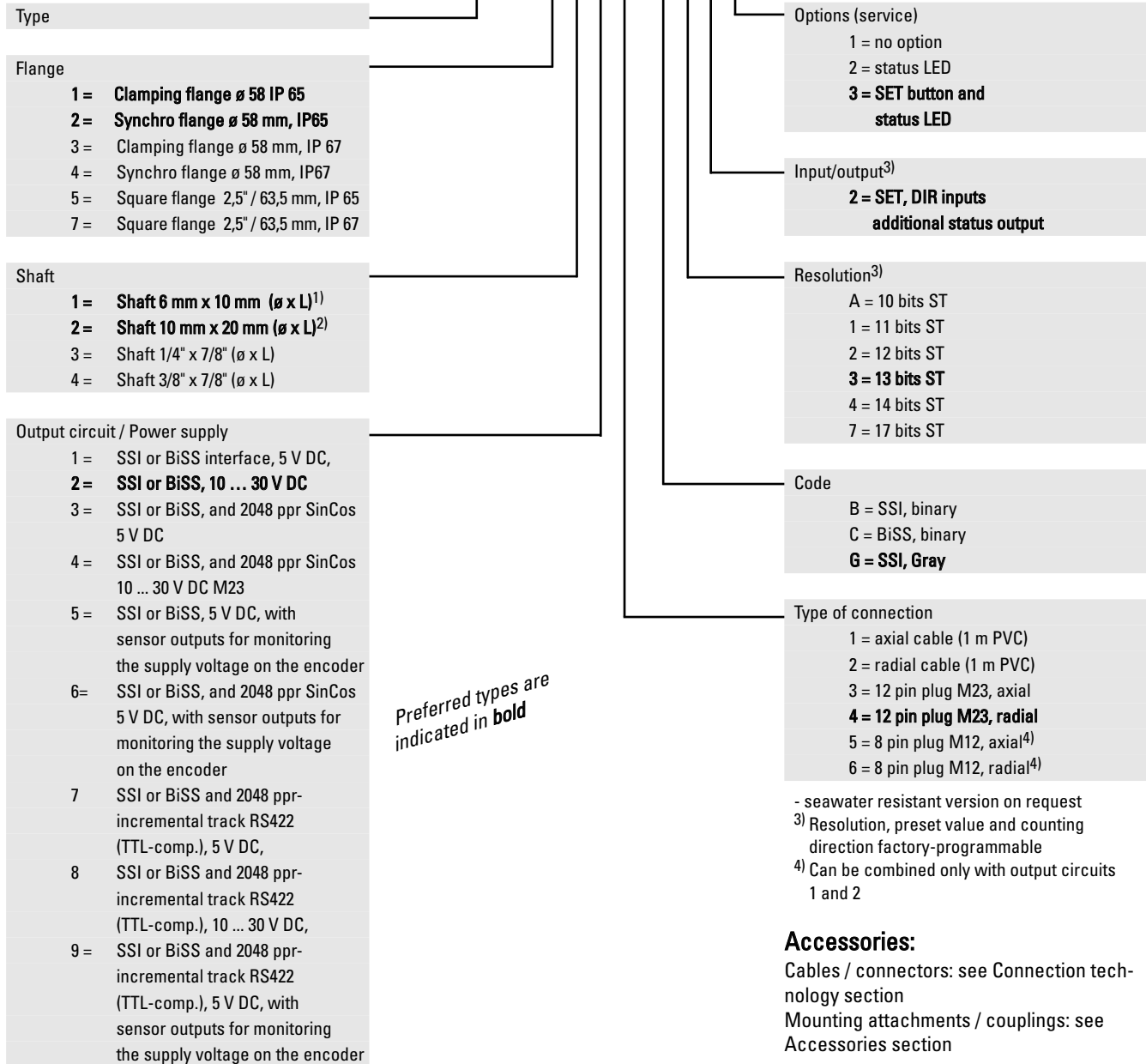

¹⁾ Preferred type with flange type 2

²⁾ Preferred type with flange type 1

Accessories:

Cables / connectors: see Connection technology section

Mounting attachments / couplings: see Accessories section

Rotary Measuring Technology

Absolute encoders, Singleturn, SSI/BiSS

Sendix absolut, Singleturn Type 5853 (Shaft) / 5873 (Hollow shaft), SSI/BiSS

Dimensions hollow shaft version:

Flange with long torque stop

ø 58 mm, M12, M23 connector, cable versions

Flange type 1 and 2 (Drawing with M12 connector)

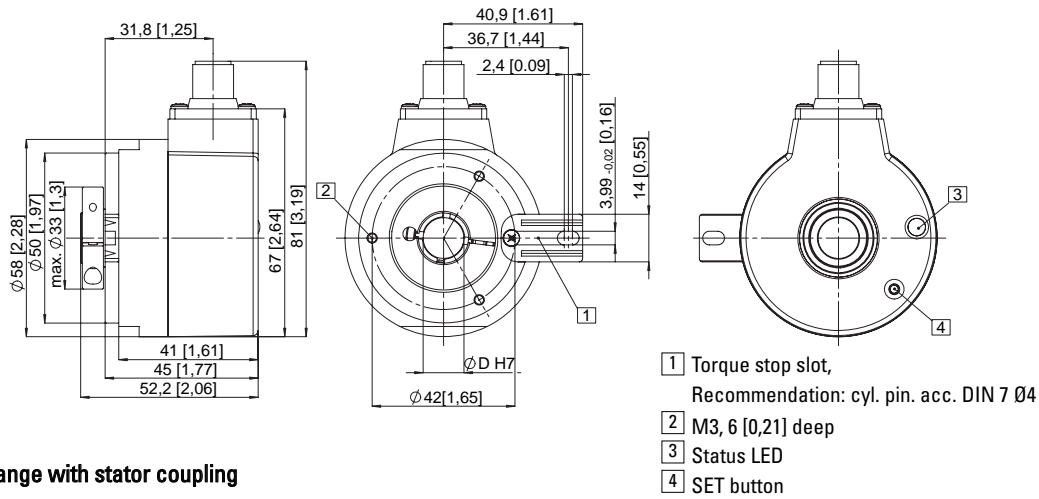

Flange with stator coupling

ø 58 mm, M12, M23 connector, cable versions

Flange type 5 and 6, pitch circle ø 63 mm (Drawing with M23 connector)

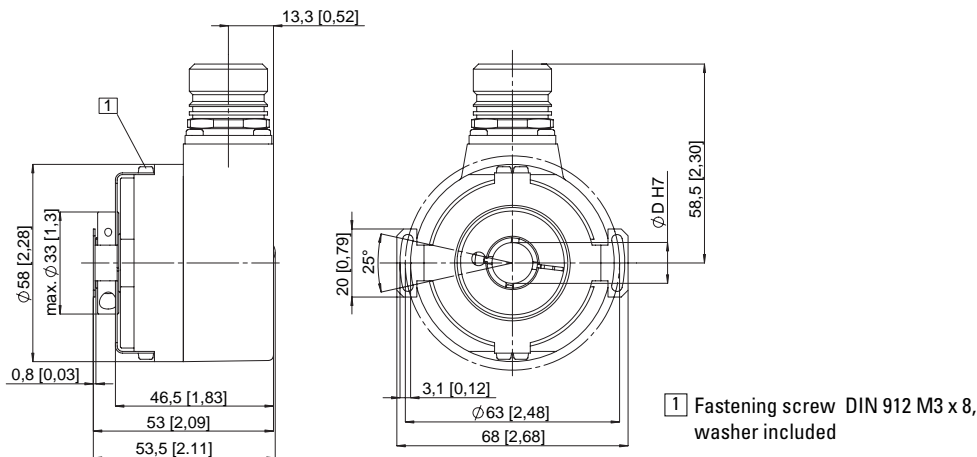

Flange with stator coupling

ø 58 mm, M12, M23 connector, cable versions

Flange type 3 and 4, pitch circle ø 65 mm (Drawing with cable version)

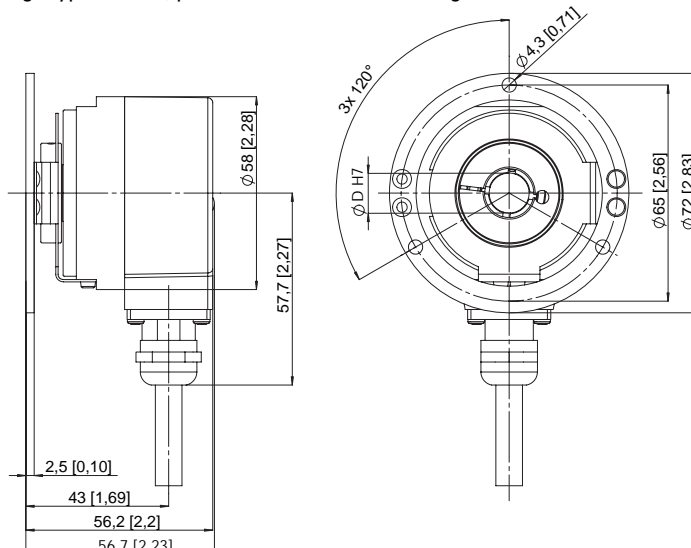

Sendix absolut, Singleturn Type 5853 (Shaft) / 5873 (Hollow shaft), SSI/BiSS

Dimensions hollow shaft version:

Flange with long torque stop

ø 58 mm, tangential cable outlet

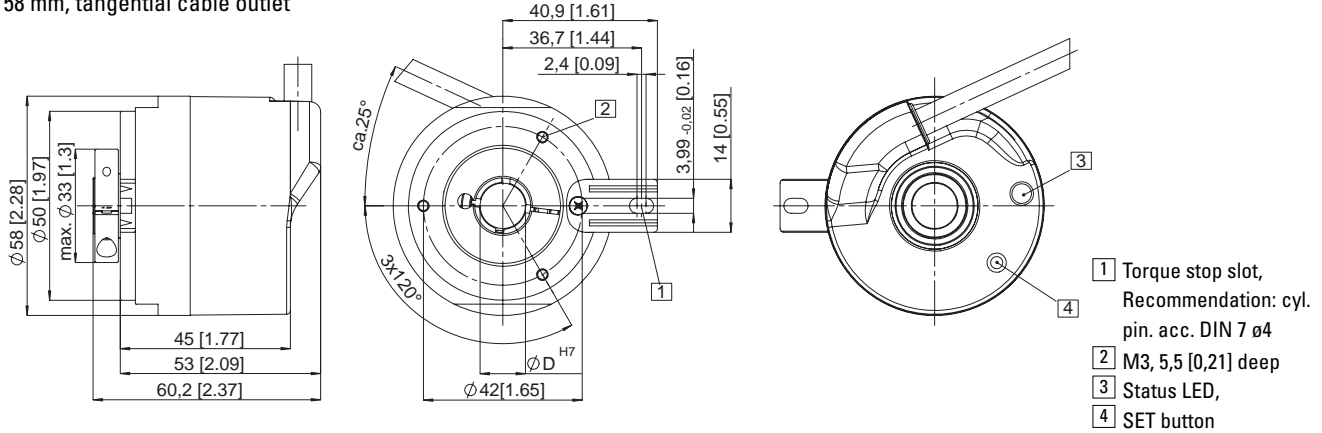

Order code hollow shaft version:

8 . 5 8 7 3 . X X X X . X X X X

10 by 10

<p>Type</p>	<p>Flange</p> <ul style="list-style-type: none"> 1 = Flange with torque stop IP 65 2 = Flange with torque stop IP 67 3 = Flange with stator coupling pitch circle ø 65, IP 65 4 = Flange with stator coupling pitch circle ø 65, IP 67 5 = Flange with stator coupling pitch circle ø 63, IP 65 6 = Flange with stator coupling pitch circle ø 63, IP 67 	<p>Hollow shaft</p> <ul style="list-style-type: none"> 3 = ø 10 mm 4 = ø 12 mm 5 = ø 14 mm 6 = ø 15 mm 8 = ø 9,52 mm [3/8"] 9 = ø 12,7 mm [1/2"] 	<p>Options (service)</p> <ul style="list-style-type: none"> 1 = no option 2 = status LED 3 = SET button and status LED 	<p>Input/output³⁾</p> <ul style="list-style-type: none"> 2 = SET, DIR inputs additional status output 	<p>Resolution³⁾</p> <ul style="list-style-type: none"> A = 10 bits ST 1 = 11 bits ST 2 = 12 bits ST 3 = 13 bits ST 4 = 14 bits ST 7 = 17 bits ST 	<p>Code</p> <ul style="list-style-type: none"> B = SSI, binary C = BiSS, binary G = SSI, Gray 	<p>Type of connection</p> <ul style="list-style-type: none"> 2 = radial cable (1 m PVC) 4 = 12 pin plug M23, radial 6 = 8 pin plug M12, radial⁴⁾ E = Tangential cable outlet (1 m PVC cable) <p>- seawater resistant version on request</p>
<p>Output circuit / Power supply</p> <ul style="list-style-type: none"> 1 = SSI or BiSS interface, 5 V DC, 2 = SSI or BiSS, 10 ... 30 V DC 3 = SSI or BiSS, and 2048 ppr SinCos 5 V DC 4 = SSI or BiSS, and 2048 ppr SinCos 10 ... 30 V DC M23 5 = SSI or BiSS, 5 V DC, with sensor outputs for monitoring the supply voltage on the encoder 6 = SSI or BiSS, and 2048 ppr SinCos 5 V DC, with sensor outputs for monitoring the supply voltage on the encoder 	<p>7 SSI or BiSS and 2048 ppr-incremental track RS422 (TTL-comp.), 5 V DC,</p> <p>8 SSI or BiSS and 2048 ppr-incremental track RS422 (TTL-comp.), 10 ... 30 V DC,</p> <p>9 = SSI or BiSS and 2048 ppr-incremental track RS422 (TTL-comp.), 5 V DC, with sensor outputs for monitoring the supply voltage on the encoder</p>	<p><i>Preferred types are indicated in bold</i></p>					

³⁾ Resolution, preset value and counting direction factory-programmable
⁴⁾ Can be combined only with output circuits 1 and 2

Accessories:
 Cables / connectors: see Connection technology section
 Mounting attachments / couplings: see Accessories section