

Absolute Encoders - Singleturn

Standard, optical	5852 / 5872 (Shaft / Hollow shaft)	Parallel, Highspeed
-------------------	------------------------------------	---------------------



The singleturn encoders 5852 and 5872 with parallel interface and optical technology achieve a very high refresh rate of the position data of 40 kHz with a resolution of max. 14 bits.



High rotational speed	Temperature -20° + 85°	High IP value	High shaft load capacity	Shock / vibration resistant	Magnetic field proof	Optical sensor

Adaptable

- Power supply 5 V DC or 10 ... 30 V DC
- Cable or connector

Fast

- Refresh rate of the position data 40 kHz

Absolute Encoders
Singleturn

Order code Shaft version	8.5852 <small>Type</small>	. XX <small>a</small>	XX <small>c d</small>	. XXX <small>e</small>	1
a <i>Flange, shaft</i> 12 = clamping flange with shaft ø 10 x 20 mm 21 = synchro flange with shaft ø 6 x 10 mm	c <i>Output circuit / Power supply</i> 1 = Parallel (CMOS-TTL) / 5 V DC 3 = Parallel / 10 ... 30 V DC	e <i>Code type and Division</i> E03 = 360 Gray-Excess E01 = 1000 Gray-Excess E14 = 1440 Gray-Excess E20 = 2000 Gray-Excess G10 = 1024 (10 bit) Gray G12 = 4096 (12 bit) Gray G13 = 8192 (13 bit) Gray G14 = 16384 (14 bit) Gray (Other divisions and code types on request)			
d <i>Type of connection</i> 1 = axial cable (1 m PVC) 2 = radial cable (1 m PVC) 3 = M23 connector, axial, without mating connector 5 = M23 connector, radial, without mating connector					

Order code Hollow shaft	8.5872 <small>Type</small>	. XXXX <small>a b c d</small>	. XXX <small>e</small>	1
a <i>Flange</i> 1 = with through hollow shaft 3 = with stator coupling	c <i>Output circuit / Power supply</i> 1 = Parallel (CMOS-TTL) / 5 V 3 = Parallel / 10 ... 30 V	e <i>Code type and Division</i> E03 = 360 Gray-Excess E01 = 1000 Gray-Excess E14 = 1440 Gray-Excess E20 = 2000 Gray-Excess G10 = 1024 (10 bit) Gray G12 = 4096 (12 bit) Gray G13 = 8192 (13 bit) Gray G14 = 16384 (14 bit) Gray (Other divisions and code types on request)		
b <i>Hollow shaft</i> 6 = ø 10 mm 8 = ø 12 mm	d <i>Type of connection</i> 1 = radial cable (1 m PVC) 2 = M23 connector, radial, without mating connector			

Absolute Encoders - Singleturn

Standard, optical	5852 / 5872 (Shaft / Hollow shaft)	Parallel, Highspeed
--------------------------	---	----------------------------

Mounting accessory for shaft encoders

Coupling	Bellows coupling ø 19 mm for shaft 6 mm	8.0000.1101.0606
	Bellows coupling ø 19 mm for shaft 10 mm	8.0000.1101.1010

Mounting accessory for hollow shaft encoders

Cylindrical pin, long for torque stops		With fixing thread	8.0010.4700.0000
--	--	--------------------	-------------------------

Connection Technology

Connector, self-assembly	M23	8.0000.5012.0000
Cordset, pre-assembled with 2 m PVC cable	M23, for parallel interface	8.0000.6741.0002

Further accessories can be found in the Accessories section or in the Accessories area of our website at: www.kuebler.com/accessories.
Additional connectors can be found in the Connection Technology section or in the Connection Technology area of our website at: www.kuebler.com/connection_technology.

Mechanical characteristics		
Speed	shaft version	max. 12000 min ⁻¹
	hollow shaft version	max. 6000 min ⁻¹ 1)
Rotor moment of inertia	shaft version	approx. 1.8 x 10 ⁻⁶ kgm ²
	hollow shaft version	approx. 6 x 10 ⁻⁶ kgm ²
Starting torque	shaft version	< 0.01 Nm
	hollow shaft version	< 0.05 Nm
Load capacity of shaft	radial	80 N
	axial	40 N
Weight		approx. 0.4 kg
Protection acc. to EN 60 529	shaft version	IP65
	hollow shaft version	IP66
Working temperature range		-20°C ... +85°C 2)
Materials	shaft / hollow shaft	stainless steel
Shock resistance acc. EN 60068-2-27		2500 m/s ² , 6 ms
Vibration resistance acc. EN 60068-2-6		100 m/s ² , 10...2000 Hz

Electrical characteristics Parallel interface		
Power supply (U_B)	5 V DC (± 5 %)	10 ... 30 V DC
Output driver	CMOS-TTL	Push-Pull
Power consumption (no load)	typ.	40 mA
	max.	75 mA
Permissible load / channel	max. +0.5 / -2.0 mA	max. +/- 10 mA
Refresh rate of the position data	40.000/s	40.000/s
Signal level	high	min. 3.4 V
	low	max. 0.3 V
		min. U _B - 2.8 V
		max. 1.8 V
Falling edge time t_f (without cable)	max. 0.2 µs	max. 1µs
Rising edge time t_r (without cable)	max. 0.2 µs	max. 1µs
Short circuit proof outputs³⁾	yes	yes
Reverse connection of the supply voltage	no	yes
UL-certified	File 224618	
CE compliant acc. to	EN 61000-6-2, EN 61000-6-4 and EN 61000-6-3	
RoHS compliant acc. to	EU guideline 2002/95/EG	

Reverse count direction

(Only with output type 3 and up to 13 bit Gray code available)

Normal operation:

Rising code values when shaft turning clockwise (cw). Falling code values when shaft turning counterclockwise (ccw)

Reverse operation:

Output MSB inverted (pin 16) instead of output MSB (pin 3) connected. Falling code values when shaft turning clockwise (cw). Rising code values when shaft turning counterclockwise (ccw), top view of shaft.

Top view of mating side, male contact base

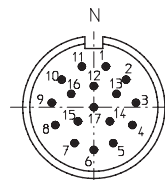

M23 connector, 17-pin (parallel)

Terminal assignment

Signal	0V	+U _B	1	2	3	4	5	6	7	8	9	10	11	12	13	14 (V/R) ⁴⁾			
Cable colour	WH	BN	GN	YE	GY	PK	BU	RD	BK	VT	GY PK	RD BU	WH GN	BN GN	WH YE	YE BN			
Pin	1	2	3	4	5	6	7	8	9	10	11	12	13	14	15	16	17	PH	

Signal: 1 =MSB; 2 = MSB-1; 3 = MSB-2 etc.

PH: Plug housing

Isolate unused outputs before initial start-up.

1) For continuous operation max. 1500 min⁻¹
2) 70°C for 14 bit version

3) If supply voltage U_B correctly applied.
4) V/R only with output circuit 3 up to max. 13 bit. MSB to change the count direction

Absolute Encoders - Singleturn

Standard, optical	5852 / 5872 (Shaft / Hollow shaft)	Parallel, Highspeed
--------------------------	---	----------------------------

Dimensions shaft version

Clamping flange with shaft \varnothing 10 mm

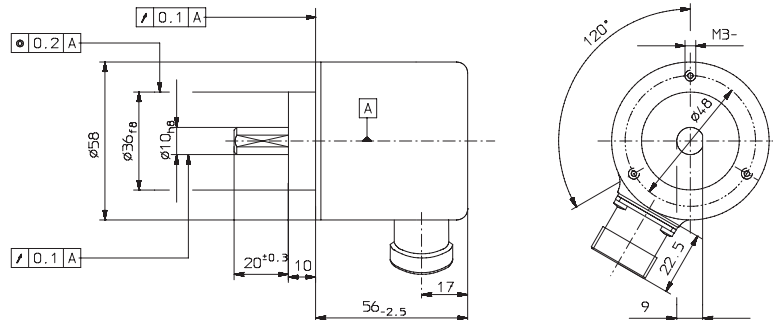

Synchro flange with shaft \varnothing 6 mm

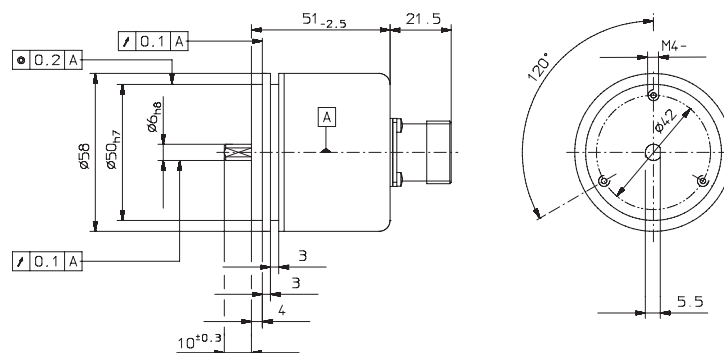

Mounting advice

The flanges and shafts of the encoder and drive should not both be rigidly coupled together at the same time! We recommend the use of suitable couplings (see Accessories section).

Dimensions hollow shaft version

Flange type 1 with torque stop set

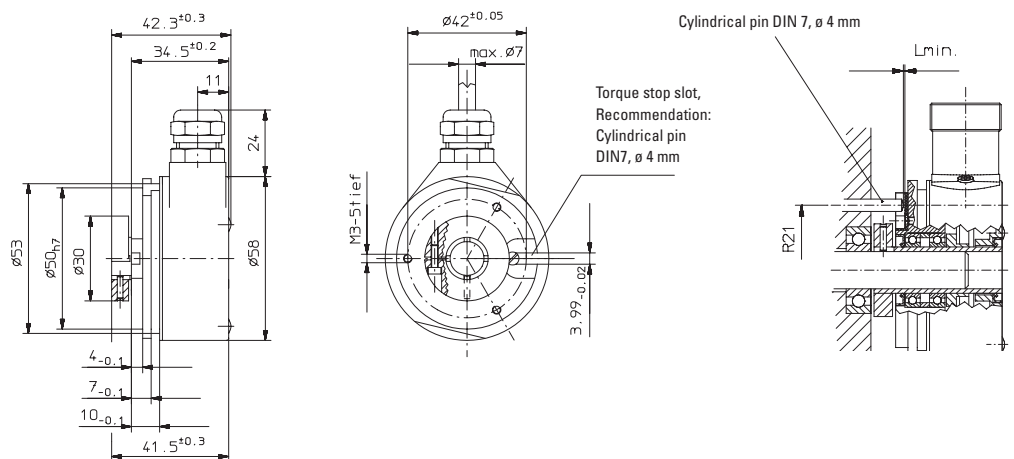

Flange type 3 with stator coupling

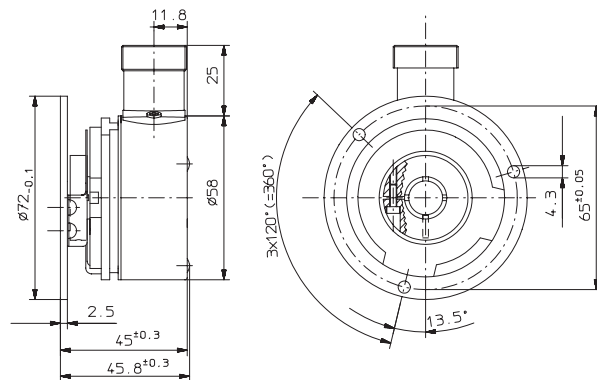

Mounting advice

- 1) The flanges and shafts of the encoder and drive should not both be rigidly coupled together at the same time!
- 2) When mounting a hollow shaft encoder, we recommend using the torque stop pin or a stator coupling.
- 3) When mounting the encoder ensure that the dimension Lmin. is larger than the maximum axial play of the drive. Otherwise there is a danger that the device could mechanically seize up.