

Incremental Encoders

Stainless steel, optical

Sendix 5826 (Hollow shaft)

Push-Pull / RS422



Thanks to their stainless-steel housing, the incremental hollow shaft encoders type 5826 are particularly suitable for those applications that make high demands on the composition and properties of the materials used.

Stainless steel encoders are therefore often used in areas subjected to aggressive cleaning materials, as a result of high hygiene requirements.



High rotational speed



Temperature
-20° + 80°



High IP value



Shock / vibration resistant



Magnetic field proof



Short-circuit proof



Optical sensor

Custom-fit

- With cable connection
- Through hollow shaft with 10 mm or 12 mm diameter
- Protection up to IP66

Adaptable

- High resolution up to 5000 PPR
- Numerous connection possibilities, thanks to wide range of interfaces and supply voltages

Order code
Hollow shaft

8.5826 . **1** **X** **X** **1** . **XXXX**
Type a b c d e

a Flange
1 = with through shaft

b Hollow shaft
6 = ø 10 mm with seal
8 = ø 12 mm with seal

c Output circuit / Power supply
1 = RS422 (with inverted signal) / 5 V DC
2 = Push-Pull (without inverted signal) / 10 ... 30 V DC
3 = Push-Pull (with inverted signal) / 10 ... 30 V DC
4 = RS422 (with inverted signal) / 10 ... 30 V DC
5 = Push-Pull (without inverted signal) / 5 ... 30V DC
6 = Push-Pull (with inverted signal) / 5 ... 30 V DC
7 = RS422 (with inverted signal) / 5 ... 30 V DC

d Type of connection
1 = radial cable (1 m PVC cable)

e Pulse rate
25, 50, 60, 100, 125, 200, 250, 256, 300, 360, 500, 512, 600, 720, 800, 1000, 1024, 1200, 1250, 1500, 2000, 2048, 2500, 3000, 3600, 4000, 4096, 5000
(e.g. 100 pulses => 0100)
Other pulse rates on request

Terminal assignment

Signal	0 V	0 V Sensor ¹⁾	+U _B	+U _B Sensor ¹⁾	A	\bar{A}	B	\bar{B}	0	$\bar{0}$
Cable colour	WH	GY PK	BN	BU RD	GN	YE	GY	PK	BU	RD

If the circuits are not being used, then they should be individually isolated and not connected.

Using RS422 outputs and long cable distances, a wave impedance has to be applied at each cable end.

Isolate unused outputs before initial start-up.

1) The sensor cables are connected to the supply voltage internally.
If long feeder cables are involved they can be used to adjust or control the voltage at the encoder.

Incremental Encoders

Stainless steel, optical	Sendix 5826 (Hollow shaft)	Push-Pull / RS422
---------------------------------	-----------------------------------	--------------------------

Mechanical characteristics	
Speed	max. 6000 min ⁻¹ 1)
Rotor moment of inertia	approx. 6.0 x 10 ⁻⁶ kgm ²
Starting torque	< 0.05 Nm
Weight	approx. 0.4 kg
Protection acc. to EN 60 529	IP66
Working temperature range	without seal -20°C ... +80°C
Materials	shaft stainless steel
Shock resistance acc. EN 60068-2-27	2000 m/s ² , 6 ms
Vibration resistance acc. EN 60068-2-6	100 m/s ² , 10 ... 2000 Hz

Electrical characteristics		
Output circuit	RS422 (TTL-compatible)	Push-Pull
Power supply	5 V (±5 %) or 10 ... 30 V DC	10 ... 30 V DC
Power consumption (no load)		
without inverted signal	–	typ. 55 mA / max. 125 mA
with inverted signal	typ. 40 mA / max. 90 mA	typ. 80 mA / max. 150 mA
Permissible load / channel	max. ±20 mA	max. ±30 mA
Pulse frequency	max. 300 kHz	max. 300 kHz
Signal level	high min. 2.5 V low max. 0.5 V	min. U _B - 2.5 V max. 2.0 V
Rising edge time t_r	max. 200 ns	max. 1 µs
Falling edge time t_f	max. 200 ns	max. 1 µs
Short circuit proof outputs 2)	yes 3)	yes
Reverse connection of the supply voltage	no; 10 ... 30 V: yes	yes
CE compliant acc. to	EN 61000-6-1, EN 61000-6-4 and EN 61000-6-3	

Incremental Encoders

Dimensions

- 1) Torque stop slot, Recommendation: Cylindrical pin DIN7, ø 4 mm
- 2) 3 x M3, 5 [0.2] deep

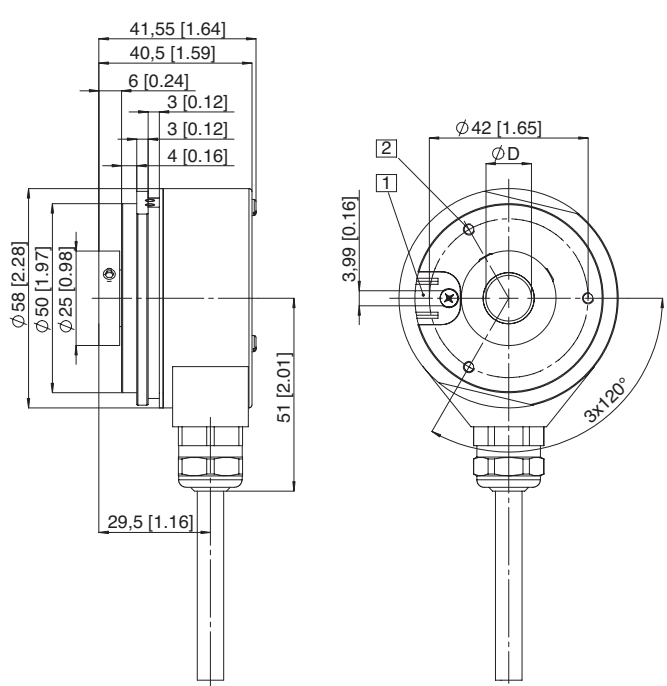

Mounting advice:

- 1) The flanges and shafts of the encoder and drive should not both be rigidly coupled together at the same time.
- 2) When mounting a hollow shaft encoder, we recommend using a torque stop pin that fits into the torque stop slot or a stator coupling.
- 3) When mounting the encoder ensure the dimension L_{min.} is greater than the axial maximum play of the drive. Otherwise there is a danger that the device could mechanically seize up.

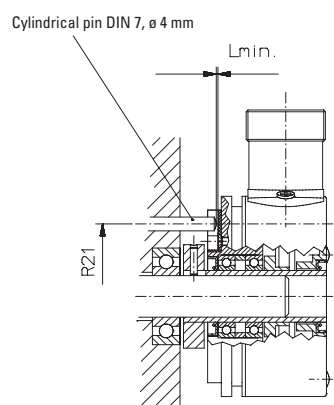

1) For continuous operation 3000 min⁻¹, ventilated
 2) If supply voltage correctly applied.
 3) Only one channel allowed to be shorted-out:
 If U_B = 5 V, short-circuit to channel, 0 V, or +U_B is permitted.
 If U_B = 5 - 30 V, short-circuit to channel or 0 V is permitted.