

### Economy Encoder Type 3700 (shaft) / 3720 (hollow shaft)



- Compact size only  $\varnothing 37 \times 33$  mm
- Hollow shaft version: Very easy mounting. The encoder is mounted directly on the drive shaft without couplings. This saves up to 30 % cost and 60 % clearance compared to shaft versions.
- Temperature- and ageing compensation
- Short circuit proof outputs
- Resolution up to 1024 ppr
- Protection up to IP 67

- Flange and cover made from a new High-Tech-Material (composite material)
- High component integration leads to low profile design, high performance and economical pricing
- "Tube Tech®" cable outlet guarantees 10x higher strain relief than traditional cabling methods and ensures IP 67 protection
- 1 1/2" (37 mm) diameter housing suitable for replacing resolvers

#### Mechanical characteristics:

Speed:	max. 6000 min <sup>-1</sup>
Rotor moment of inertia:	Shaft version: approx. $0.4 \times 10^{-6}$ kgm <sup>2</sup> Hollow shaft version: approx. $1.4 \times 10^{-6}$ kgm <sup>2</sup>
Starting torque:	Shaft version: < 0.007 Nm Hollow shaft version: < 0,01 Nm
Radial load capacity of the shaft:	20 N
Axial load capacity of the shaft:	10 N
Weight:	approx. 0.1 kg
Protection acc. to EN 60 529:	bearing, shaft: IP 65 cable outlet: IP 67
Working temperature:	-20° C up to +70 °C <sup>1)2)</sup>
Materials:	Shaft/hollow shaft: stainless steel; housing, flange: composite PPA, 40% KF (carbon fibre) cable: PVC
Shock resistance acc. to DIN-IEC 68-2-27:	1000 m/s <sup>2</sup> , 6 ms
Vibration resistance acc. to DIN-IEC 68-2-6:	100 m/s <sup>2</sup> , 10 ... 2000 Hz

1) For versions with push-pull output and supply voltage >15 V DC: max. 55 °C

2) Non-condensing

#### Electrical characteristics:

Output circuit:	RS 422 (TTL-compatible)	Push-pull (7272) <sup>3)</sup>	Push-pull (7272) <sup>3)</sup>
Supply voltage:	5 V ( $\pm 5\%$ )	5 ... 30 V DC	10 ... 30 V DC
Power consumption (no load) with inverted signal:	typ. 40 mA / max. 90 mA	typ. 50 mA/ max. 100 mA	typ. 50 mA/ max. 100 mA
Permissible load/channel:	max. $\pm 20$ mA	max. $\pm 20$ mA	max. $\pm 20$ mA
Pulse frequency:	max. 250 kHz	max. 250 kHz	max. 250 kHz
Signal level high:	min. 2.5 V	min. $U_B - 2.0$ V	min. $U_B - 2.0$ V
Signal level low:	max. 0.5 V	max. 0.5 V	max. 0.5 V
Rise time $t_r$	max. 200 ns	max. 1 $\mu$ s	max. 1 $\mu$ s
Fall time $t_f$	max. 200 ns	max. 1 $\mu$ s	max. 1 $\mu$ s
Short circuit proof outputs <sup>1)</sup> :	yes <sup>2)</sup>	yes	yes
Reverse connection protection at $U_B$ :	no	no	yes
UL certified	File 224618		
Conforms to CE requirements acc. to EN 61000-6-2, EN 61000-6-4 and EN 61000-6-3			
RoHS compliant acc. to EU guideline 2002/95/EG			

1) If supply voltage correctly applied

2) Only one channel allowed to be shorted-out:  
(at  $U_B = 5$  V short circuit to channel, 0 V, or + $U_B$  is permitted).

3) Max. recommended cable length 30 m



### Economy Encoder Type 3700 (shaft) / 3720 (hollow shaft)

#### Dimensions hollow shaft version:

Short torque stop version;  
Long torque stop version is shown dashed

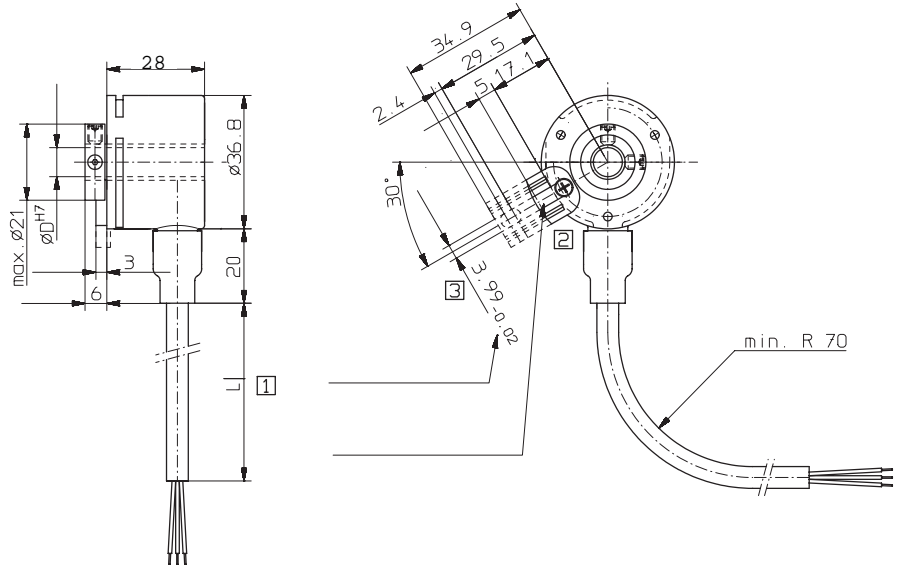

#### Stator coupling version

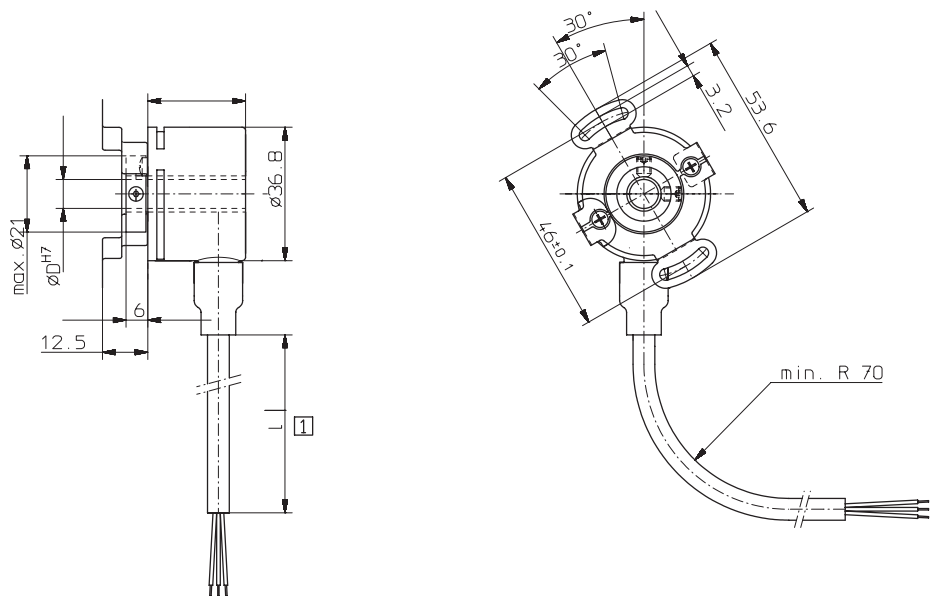

- 1 cable length 1, 2, 3 or 5 m
- 2 Slot for torque stop, 3 mm deep
- 3 Recommended pin for long torque stop  
Cyl. pin acc. to DIN 7 ø 4 mm

### Economy Encoder Type 3700 (shaft) / 3720 (hollow shaft)

Order code: hollow shaft version:

**8.3720.XXXX.XXXX**



Type	
Flange	
1 =	Hollow shaft with short torque stop
2 =	Hollow shaft with long torque stop
5 =	Hollow shaft with stator coupling
Hollow shaft	
1 =	∅ 4 mm
2 =	∅ 5 mm
3 =	∅ 6 mm
4 =	∅ 1/4"
6 =	∅ 8 mm

Pulse rate	10, 50, 60, 100, 180, 200, 250, 300, 360, 400, 500, 512, 600, 1000, 1024 (e.g. 250 pulses => 0250) Other pulse rates available on request
Type of connection	1 = Cable* radial (1 m PVC-cable) 2 = Cable* radial (2 m PVC-cable) 3 = Cable* radial (3 m PVC-cable) 4 = Cable* radial (5 m PVC-cable)
Output and voltage supply	1 = RS 422: 5 V DC ±5 % 3 = Push pull (with inverted signals) 5 ... 30 V DC 4 = Push pull (with inverted signals) 10 ... 30 V DC

<b>Stock types</b>
8.3720.5631.0100
8.3720.5631.0360
8.3720.5631.0500
8.3720.5631.1000
8.3720.5631.1024
8.3720.5611.0512
8.3720.5611.1024

\* "Tube Tech<sup>®</sup>" cable outlet guarantees 10x higher strain relief than traditional cabling methods plus higher IP-Protection.  
Other cable lengths are available on request.

Accessories:  
Cyl. pin acc. to DIN 7 ∅ 4 mm  
Art-no.: 8.0010.4700.0000

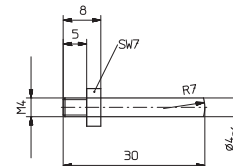

**Accessories:**  
Cables and connectors, also pre-assembled, can be found in the chapter Connection Technology  
Mounting attachments and couplings can be found in the chapter Accessories