

Incremental Encoders

Miniature, optical	2400 / 2420 (Shaft / Hollow shaft)	Push-Pull
---------------------------	---	------------------



The incremental miniature encoders type 2400 / 2420 with their optical sensor technology offer a resolution of up to 1024 PPR.

With a diameter of just 24 mm this encoder is ideal for use where space is tight.



High rotational speed	Temperature -20° +85°	Shock / vibration resistant	Short-circuit proof	Magnetic field proof	Optical sensor

Reliable

- Robust bearing construction
- Cable outlet boasts high degree of strain relief thanks to multiple clamping.
- Short-circuit proof inputs

Versatile

- Ideally suited for use in small devices
- Meets the certification requirements of Railways Standard EN 50121

Order code Shaft version

05.2400	. XXXX .	XXXX
Type	a b c d	e

If for each parameter of an encoder the underlined preferred option is selected, then the delivery time will be 10 working days for a maximum of 10 pieces. Qts. up to 50 pcs. of these types generally have a delivery time of 15 working days.



a Flange

- 1 = ø 24 mm
- 2 = ø 30 mm
- 3 = ø 28 mm

b Shaft (ø x L)

- 1 = ø 4 x 10 mm
- 2 = ø 6 x 10 mm
- 3 = ø 5 x 10 mm, with flat

c Output circuit / Power supply

- 1 = Push-Pull (without inverted signal) / 5 ... 24 V DC
- 2 = Push-Pull (with inverted signal) / 5 ... 24 V DC
- 3 = Push-Pull (without inverted signal) / 8 ... 30 V DC
- 4 = Push-Pull (with inverted signal) / 8 ... 30 V DC

d Type of connection

- 1 = axial cable (2 m PVC cable ø 4.5 mm)
- 2 = radial cable (2 m PVC cable ø 4.5 mm)

e Pulse rate

- 4, 6, 8, 10, 16, 20, 25, 36, 40, 50, 60, 80, 100, 120, 125, 180, 200, 250, 300, 360, 400, 500, 512, 1000, 1024
- (e.g. 360 pulses => 0360)
- Other pulse rates on request

Stock types

- 05.2400.1122.0050
- 05.2400.1122.0360
- 05.2400.1122.0500
- 05.2400.1122.1000
- 05.2400.1122.1024

Order code Hollow shaft

05.2420	. 1XXX .	XXXX
Type	a b c d	e

If for each parameter of an encoder the underlined preferred option is selected, then the delivery time will be 10 working days for a maximum of 10 pieces. Qts. up to 50 pcs. of these types generally have a delivery time of 15 working days.



a Flange

- 1 = ø 24 mm

b Blind hollow shaft

(insertion depth max. 14 mm)

- 1 = ø 4 mm
- 2 = ø 6 mm

c Output circuit / Power supply

- 1 = Push-Pull (without inverted signal) / 5 ... 24 V DC
- 2 = Push-Pull (with inverted signal) / 5 ... 24 V DC
- 3 = Push-Pull (without inverted signal) / 8 ... 30 V DC
- 4 = Push-Pull (with inverted signal) / 8 ... 30 V DC

d Type of connection

- 1 = axial cable (2 m PVC cable ø 4.5 mm)
- 2 = radial cable (2 m PVC cable ø 4.5 mm)

e Pulse rate

- 4, 6, 8, 10, 16, 20, 25, 36, 40, 50, 60, 80, 100, 120, 125, 180, 200, 250, 300, 360, 400, 500, 512, 1000, 1024
- (e.g. 360 pulses => 0360)
- Other pulse rates on request

Stock types

- 05.2420.1212.0360
- 05.2420.1212.0500
- 05.2420.1212.1000
- 05.2420.1222.0500
- 05.2420.1222.1000
- 05.2420.1222.1024

Mounting accessory for shaft encoders

Coupling

Bellows coupling ø 15 mm for shaft 4 mm

8.0000.1201.0404

Further accessories can be found in the Accessories section or in the Accessories area of our website at: www.kuebler.com/accessories.
Additional connectors can be found in the Connection Technology section or in the Connection Technology area of our website at: www.kuebler.com/connection_technology.

Incremental Encoders

Miniature, optical	2400 / 2420 (Shaft / Hollow shaft)	Push-Pull
---------------------------	---	------------------

Mechanical characteristics		
Speed		max. 12 000 min ⁻¹
Rotor moment of inertia		approx. 0.1 x 10 ⁻⁶ kgm ²
Starting torque		< 0.01 Nm
Shaft load capacity	radial	10 N
	axial	20 N
Weight		approx. 0.06 kg
Protection to EN 60529	housing side	IP65
	flange side	IP50 (IP64 on request)
Working temperature range		-20°C ... +85°C
Materials	shaft	stainless steel
	hollow shaft	brass
Shock resistance acc. to EN 60068-2-27		1000 m/s ² , 6 ms
Vibration resistance acc. to EN 60068-2-6		100 m/s ² , 55 ... 2000 Hz

Electrical characteristics		
Output circuit	Push-Pull (7272) ¹⁾	Push-Pull (7272) ¹⁾
Supply voltage	5 ... 24 V DC ²⁾	8 ... 30 V DC
Power consumption (no load)	max. 50 mA	max. 50 mA
Permissible load / channel	max. 50 mA	max. 50 mA
Pulse frequency	max. 160 kHz	max. 160 kHz
Signal level	high low	min. U _B - 2.5 V max. 0.5 V
Rising edge time t_r	max. 1 μs	max. 1 μs
Falling edge time t_f	max. 1 μs	max. 1 μs
Short circuit proof outputs	yes	yes
UL-certified	File 224618	
CE compliant acc. to	EN 61000-6-2, EN 55011 Class B	
RoHS compliant acc. to	EU guideline 2002/95/EG	

Incremental Encoders

An independent test laboratory (TTI-PG115/96-01) approved by the German Accreditation Council (DAR) certified the compliance with the Railways Standard, according to EN 50121. This means our encoder is compatible with higher electromagnetic noise standards than standard industrial encoders.



You will have a higher quality encoder even in applications with higher EMC noise levels. We will gladly send you a copy of the test report on request. When ordering an encoder to the railway standard, please ensure you state this explicitly on the order.

Terminal assignment

Signal	0V	+U _B	A	\bar{A}	B	\bar{B}	0	$\bar{0}$
Cable colour with inverted signal	WH	BN	GN	YE	GY	PK	BU	RD
Cable colour without inverted signal	WH	BN	GN		YE		GY	

1) Max. recommended cable length 30 m

2) With 24 V DC there is no tolerance above 24 V DC. Please use output circuit 8 ... 30 V DC.

Incremental Encoders

Miniature, optical	2400 / 2420 (Shaft / Hollow shaft)	Push-Pull
---------------------------	---	------------------

Dimensions shaft version

Flange type 1 (ø 24 mm)

- 1 min R50 [1.97]
- 2 3 x M3, 4[0.16] deep

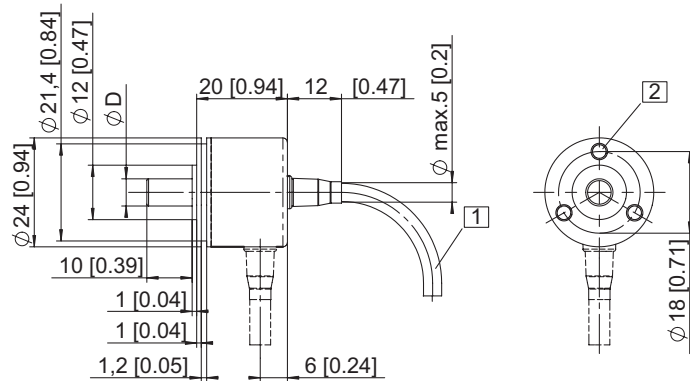

Flange type 2 (ø 30 mm) Flange type 3 (ø 28 mm)

Flange type	2	3
A	ø 30 mm	ø 28 mm
B	3 mm	2 mm

- 1 min R50 [1.97]
- 2 2 x M3, 4[0.16] deep

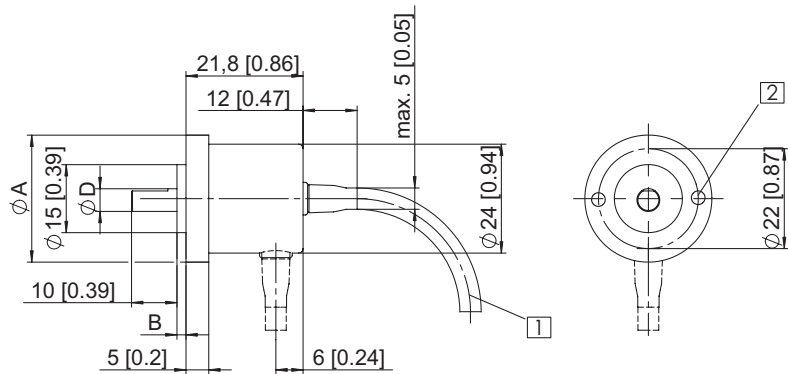

Mounting advice:

The flanges and shafts of the encoder and drive should not both be rigidly coupled together at the same time!
We recommend the use of suitable couplings (see Accessories section).

Dimensions hollow shaft version

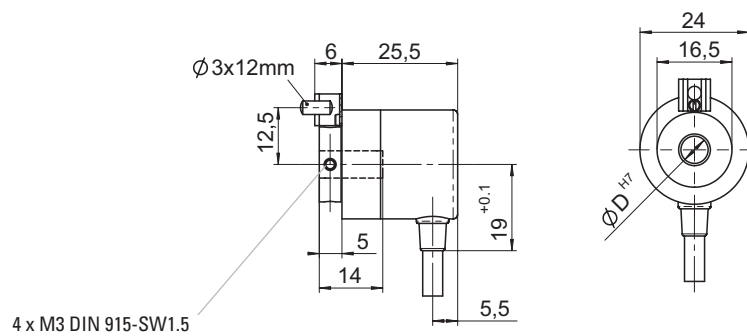

Mounting advice:

The flanges and shafts of the encoder and drive should not both be rigidly coupled together at the same time!
A cylindrical pin, for use as a torque stop, is supplied.